

Coaxial Directional Coupler

50Ω

1 to 500 MHz

ZFDC-10-1+ ZFDC-10-1



BNC version shown
CASE STYLE: K18

Maximum Ratings

Operating Temperature	-55°C to 100°C
Storage Temperature	-55°C to 100°C

Coaxial Connections

INPUT	1
OUTPUT	2
COUPLED	3

Features

- excellent directivity, 33 dB typ.
- excellent mainline loss, 0.8 dB typ.
- rugged shielded case

Applications

- VHF/UHF
- instrumentation
- communication receivers & transmitters
- amateur radio

Connectors	Model	Price	Qty.
BNC	ZFDC-10-1(+)	\$44.95	(1-9)
SMA	ZFDC-10-1-S+	\$49.95	(1-9)
N-TYPE	ZFDC-10-1-N+	\$49.95	(1-9)
BRACKET (OPTION "B")		\$5.00	(1+)

+ RoHS compliant in accordance with EU Directive (2002/95/EC)

The +Suffix identifies RoHS Compliance. See our web site for RoHS Compliance methodologies and qualifications.

Directional Coupler Electrical Specifications

FREQ. RANGE (MHz)	COUPLING (dB)		MAINLINE LOSS ¹ (dB)						DIRECTIVITY (dB)						VSWR (:1)	POWER INPUT (W)		
	Nom.	Flatness	L		M		U		L		M		U			Typ.	L	MU
			Typ.	Max.	Typ.	Max.	Typ.	Max.	Typ.	Min.	Typ.	Min.	Typ.	Min.				
1-500	10.5±0.25	±0.6	1.0	1.3	0.8	1.1	1.0	1.3	32	25	33	25	22	15	1.2	1.5	3.0	

L = low range [f_L to $10 f_L$] M = mid range [$10 f_L$ to $f_U/2$] U = upper range [$f_U/2$ to f_U]

1. Mainline loss includes theoretical power loss at coupled port.

Outline Drawing

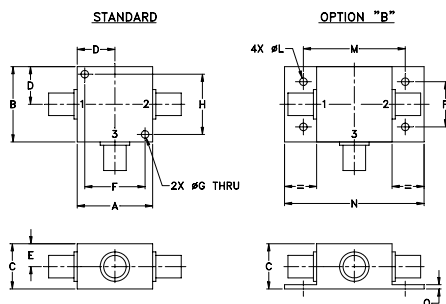

Outline Dimensions (inch/mm)

A	B	C	D	E	F	G	H
1.25	1.25	.75	.63	.38	1.00	.125	1.000
31.75	31.75	19.05	16.00	9.65	25.40	3.18	25.40

J	K	L	M	N	P	Q	wt
--	--	.125	1.688	2.18	.75	.07	grams
--	--	3.18	42.88	55.37	19.05	1.78	70.0

Typical Performance Data

Frequency (MHz)	Mainline Loss (dB) In-Out	Coupling (dB) In-Cpl	Directivity (dB)	Return Loss (dB)		Cpl
				In	Out	
1.00	0.97	10.47	58.25	25.76	18.55	19.10
5.00	0.78	10.32	57.52	32.88	20.94	21.28
9.00	0.76	10.31	57.51	33.62	21.25	21.54
67.00	0.77	10.34	46.55	30.69	21.30	21.61
143.00	0.76	10.40	38.96	26.28	20.66	21.32
220.00	0.76	10.49	33.22	23.55	19.85	20.86
270.00	0.80	10.62	30.12	22.35	19.32	20.45
330.00	0.83	10.74	27.02	21.34	18.68	19.89
405.00	0.86	10.90	23.63	20.56	18.03	19.15
500.00	0.85	11.04	20.05	20.16	17.44	18.20

ZFDC-10-1 MAINLINE LOSS

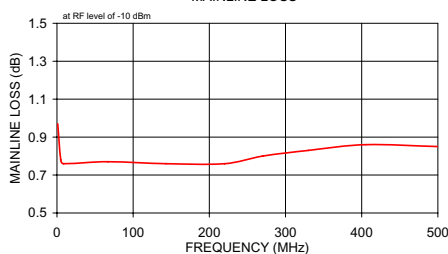

ZFDC-10-1 COUPLING & DIRECTIVITY

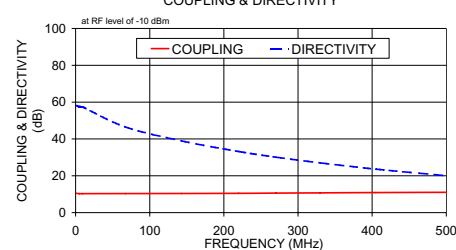

ZFDC-10-1 RETURN LOSS

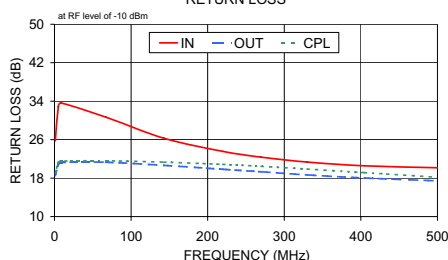

Electrical Schematic

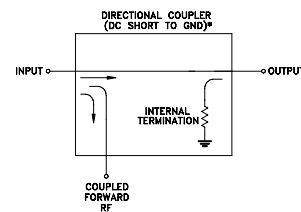

* ELECTRICAL SCHEMATIC IS FOR DIRECTIONAL COUPLER WITH INTERNAL TRANSFORMERS THAT ROUTES DC FROM RF PORTS TO GROUND.

For detailed performance specs & shopping online see web site



P.O. Box 350166, Brooklyn, New York 11235-0003 (718) 934-4500 Fax (718) 332-4661 The Design Engineers Search Engine Provides ACTUAL Data Instantly at minicircuits.com

IF/RF MICROWAVE COMPONENTS

Notes: 1. Performance and quality attributes and conditions not expressly stated in this specification sheet are intended to be excluded and do not form a part of this specification sheet. 2. Electrical specifications and performance data contained herein are based on Mini-Circuit's applicable established test performance criteria and measurement instructions. 3. The parts covered by this specification sheet are subject to Mini-Circuits standard limited warranty and terms and conditions (collectively, "Standard Terms"); Purchasers of this part are entitled to the rights and benefits contained therein. For a full statement of the Standard Terms and the exclusive rights and remedies thereunder, please visit Mini-Circuits' website at www.minicircuits.com/MCLStore/terms.jsp.

REV. C
M119986
ZFDC-10-1
WZ/TD/CP/AM
111206