

Experiments with Coils and Q-Measurement

Wes Hayward, w7zoi, October, 2007 ([Updates 01Dec07, 08Dec08.](#))

I recently became interested in building a “Zero Power Receiver (ZPR)”, a circuit that would receive the AM broadcast band while using no external power. There would be no batteries or other sources of energy. This is, of course, the classic *crystal set* that most of us built in our youth. But building a contemporary ZPR is a different exercise than it was for those youthful interludes. The main difference is the presence of considerably more science in the process than we used in the construction of that first crystal set. There are some really wonderful web sites out there that present much of this work. Another difference is that the modern ZPR may not even use a “crystal,” or diode detector. Instead, it may use a field effect transistor. The most recent published design that I know about was presented by Bob Culter, N7FKI, in QST for January, 2007. Bob used a new zero threshold MOSFET in his ZPR.



[The w7zoi amateur radio set up and listening post, September 30, 2007. A ZPR resides on top of the Icom R75 communications receiver.](#)

Those interested in finding out more about the modern crystal set should go to the world wide web with a good search engine such as Google. The first place to go is the Birmingham, Alabama Crystal Radio Group. They have a collection of links listed on their web page that will get you to many of the other really good sites. Birmingham really is the center for much of this activity, probably the result of some local activity that grew into something greater. These guys are to be commended for work that gets a lot of us thinking and trying something different. Be sure to look at their photo collection and at the results from their contests.

I'll not spend too much more space with further discussion of crystal sets here. This note is related to some of the measurement methods that I have used for Q measurements. But there is one piece of data that I do want to emphasize, for this was the thing that got my attention: The gang from Birmingham hold an annual listening contest that goes on for over a week in the dead of winter. They then collect the logs to see who is hearing the good stuff. The folks who win are not just listening to the local stations in their area. **Rather, they log stations from hundreds, and even thousands of miles away!** A winning log may well contain over a hundred stations. One recent winner was from Hawaii.

Q-Measurement using a Q-Meter

The basic ZPR has at least one tuned circuit that serves to tune the receiver to a desired station. Most of the receivers that are built by those who listen to far distant broadcasts will have several. While there is considerable lore on the web that present an algorithm for coil construction, this does not provide the numbers we need for design. If we are to really be able to analyze the circuits that we build, even in a circuit as primitive as a crystal receiver, we must do measurements on key components to characterize, and hence, model them. We must have resonator Q.

Shown below is the basic topology of a Q-Meter, the HP-4342A.

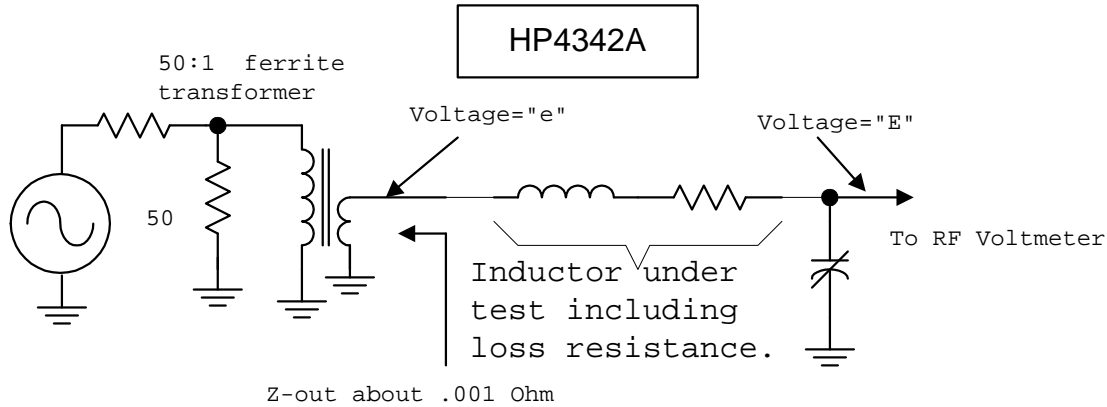

A relatively modern Q Meter. This particular model is perhaps the last of its kind.

This instrument has a built in signal generator (22 kHz up to 70 MHz) that supplies energy to a ferrite transformer with an extremely low output impedance, around one milliohm. The output has a magnitude "e". This level is maintained with a detector and feedback loop. The signal is then applied to the inductor under test, which is attached to terminals on top of the instrument. The inductor is tuned to resonance with a high quality, calibrated, built-in variable capacitor. The voltage across the capacitor is measured with a very high impedance RF voltmeter. The value of this voltage, E, is then directly related to Q. The lower the net series resistance, the higher E will be.

Some amateur experimenters have built homebrew Q meters using the HP scheme. Calibration may be a challenge, but the basic concepts are fundamental and would form a sound basis for experimental efforts. I might be tempted to try some of the very wideband op-amps that are available today as a way to generate the ultra low output impedance drive.

A modern measurement performed in industry or at an institution of higher learning will probably be done with a network analyzer. We will not go into any detail here, for that will take us far from our immediate goals. However, we should state that it is now quite possible for the amateur experimenter to build his or her own network analyzer. Some of the "antenna analyzers" now on the market edge in this direction. A network analyzer was described a few years ago in QEX. In my opinion though, the finest example of a homebrew analyzer is that presented by Paul Kiciak, N2PK. Paul's vector (meaning that it gives impedance magnitude and angle, or real + imaginary) is found on the web at <http://n2pk.com/> and offers measurements to 60 MHz with a 100 dB dynamic range.

A Still Viable Classic Q Measurement

In earlier times when a network analyzer was not as available to the experimenter as it is today, resonator (another term for tuned circuit) Q was measured by examining the bandwidth of the circuit. The Q is then just the ratio of the center frequency to the bandwidth. A system for this is shown below.

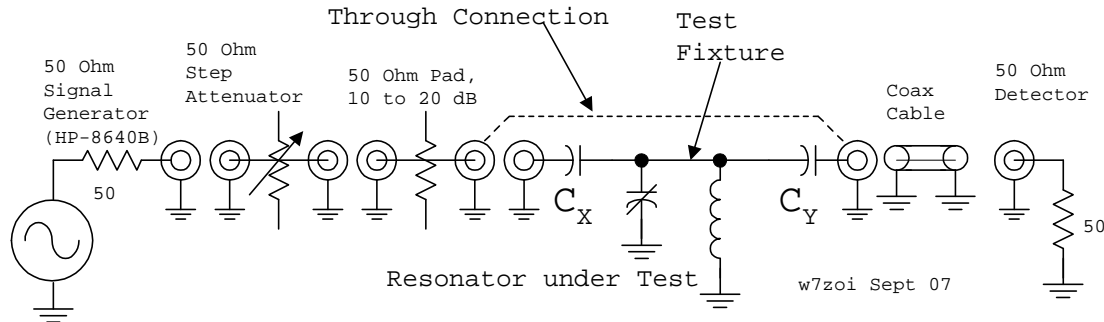

A classic scheme for measurement of Q. C_X and C_Y are adjusted for high loss. See text.

The use of this method is very general and is not restricted in frequency. I've used it to evaluate low frequency inductors used in audio filters as well as components for microwave filters. Like most RF measurements, a 50 Ohm system is used for both a driving RF source and for the load. It is vital to have digital frequency readout. A counter can be attached to an analog calibrated generator. The generator is followed by a step attenuator. This can be homebrew and is trivial for measurements up through the HF spectrum. All we will need for this measurement is a 3 dB step. However, it should be fairly accurate. (See EMRFD chapter 7 for info on attenuators.) The step attenuator is followed by a fixed pad to establish a Z0 environment. This pad should ideally be right next to the following test fixture that contains the tuned circuit we are measuring. The test fixture output is routed to a 50 Ohm detector. This can be a power meter, a spectrum analyzer (my usual choice), or a 50 Ohm terminated oscilloscope. If the 'scope option is picked, the termination should be at the input to the oscilloscope and **not** out at the test fixture end of the connecting cable. With a 50 Ohm terminator at the 'scope, the test fixture will see 50 Ohms at all frequencies, no matter what the cable length might be.

The first step in use is to put a jumper (usually a BNC barrel) from the fixed pad to the cable leading to the detector, shown as a dotted line in the figure above. The level in the detector is then noted. If you are using a 'scope, calculate the power in dBm. Power in dBm is usually read directly if you are using a power meter or spectrum analyzer. Then connect the test fixture with its tuned circuit and tune the signal generator and/or variable capacitor to obtain a detector peak. The peak response will always be less than was seen with the "through" connection. That direct connection represented a matched impedance case where all of the available power from the signal generator is transferred to the detector.

It's now time to extract some numbers. Set the step attenuator to 3 dB and then tune the generator for a peak in output response. Peak the resonator capacitor if necessary. Note the frequency for this peak response. Now comes an important part of the procedure that is easy to bypass. **Note the power seen in the detector and record it in your notebook.** It should be at least 30 dB below the maximum available power that we measured with the through connection. Let's assume, for the moment, that it is.

We now carefully note the detector level. If we are using a spectrum analyzer or an oscilloscope, we adjust the signal generator amplitude just a bit so the trace is right on a cursor line on the display. An adjustment of oscilloscope vertical position may also be used for this.

Next, remove the previously added 3 dB attenuation. This will cause the response to increase, doubling the detector power. (An oscilloscope voltage response will go up by a factor of 1.41.) Now carefully tune the signal generator to a higher frequency until the response has dropped to produce **exactly the same level** that we had at the peak. Record this upper frequency in your notebook. Next, the generator is tuned back toward and through the peak until the previously noted amplitude is again obtained. This

occurs at a lower bandwidth edge. The difference between the upper and the lower frequencies is the resonator bandwidth. The Q is then the ratio.

$$BW = F_{\text{upper}} - F_{\text{lower}}$$

$$Q = \frac{F_{\text{center}}}{BW}$$

Consider now the earlier assumption that there was at least 30 dB loss through the test fixture containing the resonator and connecting capacitors. This loss relates to the choice of CX and CY shown in the schematic diagram for the classic measurement. First, it is important that the values be approximately the same value. This guarantees that any loading by the Z0 source will equal the loading by the Z0 detector. If CY was much larger than CX, for example, we could have a situation where the detector would severely load the resonator, but we could still have 30 dB or more attenuation. So make the two loads about the same. A loss of 30 dB or more means that the dominant loss mechanism is the loss within the tuned circuit and not the loss related to loading by the source or detector.

The way we adjust the loading at the ends of this single resonator filter is by picking CX and CY. The values we use will depend upon the capacitor in the resonator. If, for example, we have a resonator capacitance of 300 pF, we can probably get our 30 dB loss with values of perhaps 3 pF for CX and CY. I would probably grab 1 pF for each part from the junk box. Exact details will change as we go to much higher frequency. The concepts are the same though. For example, when evaluating a VHF helical resonator, or similar LC-like structure, we might have nothing more than a pair of coaxial connectors mounted in the resonator wall. The normal center pins from the connectors may well be enough coupling. Indeed, I have encountered situations where it was necessary to recess the connectors in the wall so that the center wires are partially hidden. Good measurement results are guaranteed if the 30 dB rule is maintained and symmetrical loading is achieved. If the Q exceeds 500 or 1000, it may be useful to go to loss greater than 30 dB. Alternatively, a correction can be applied. See page 58 of *Introduction to RF Design* (ARRL, 1994.)

Some of these details are not intuitive. A good way to build some intuition is to do simulations in LT Spice, which is free from Linear Technology on the web. (Bravo for LT—many thanks!) You can then “build” inductors in software, with appropriate series resistance. Then sweep the filter and see if you get the right Q by observing the 3 dB points.

The procedure outlined is general and applies to any frequency. The use of low impedances allows extreme flexibility. Some folks have measured Q with a similar approach where a small probe coil is driven by the generator and is placed *near* the resonator being studied. An oscilloscope is then used with a 10X probe and a small value series capacitor as a detector. The series capacitor is important, for even with a 10X probe, the impedance at RF might still excessively load the resonator. It is important to keep the source probe inductor well away from the coil. The concepts are the same and can all be modeled with appropriate calculations.

The EMRFD Q-Measurement Scheme

An alternative scheme is presented in [Experimental Methods in RF Design](#) (ARRL, 2003) in Chapter 7, page 7.36. In this method, a tuned circuit containing the inductor to be measured is configured as a series resonator and is then connected as a shunt element. The basic scheme is shown below.

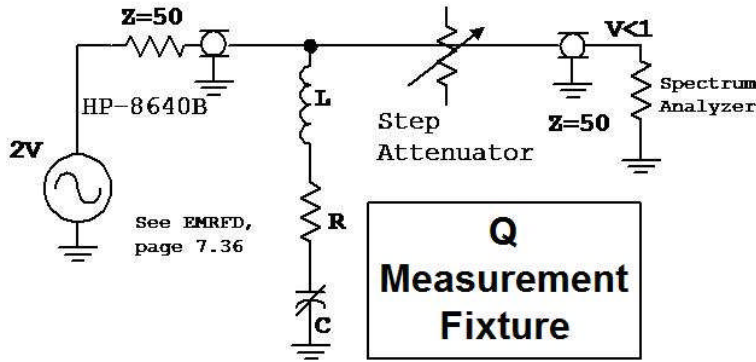

Alternative Q measurement scheme.

A steady strong output is seen in the detector as the signal generator is tuned. As resonance is reached, the output dips down. The reactance of the inductor is cancelled by that of the capacitor exactly at resonance, leaving nothing but the loss resistance, R, to attenuate the signal reaching the detector. The higher the Q, the greater the dip will become. A more detailed diagram is shown below.

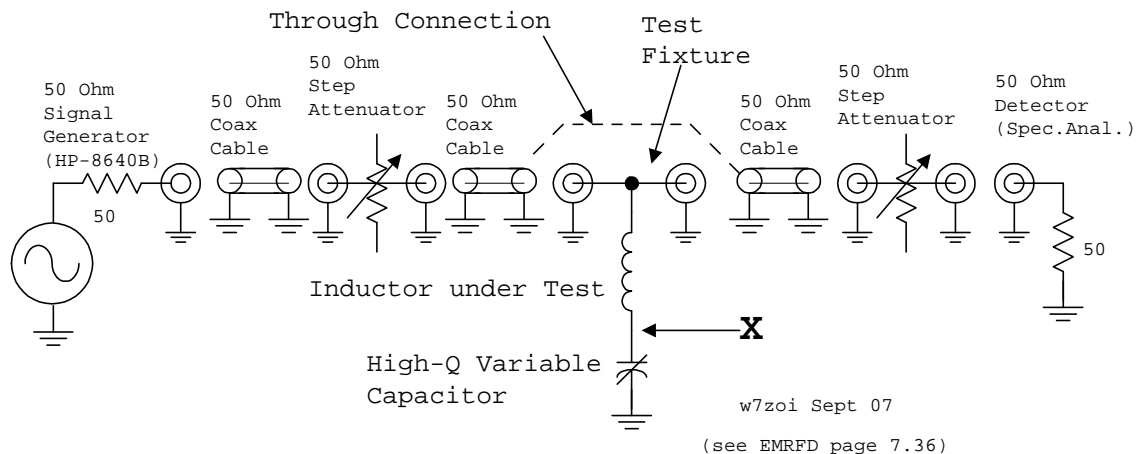

w7zoi Sept 07
(see EMRFD page 7.36)

Alternative Q measurement system. See text for explanation.

The procedure for using this method begins with setting the signal generator to the desired frequency. The level is noted in the spectrum analyzer. A power meter or 50 Ohm terminated oscilloscope can also be used if the signal generator is known to be low in harmonic content. (Not all signal generators fulfill this criterion though, so be careful. The HP-8640B that I use has very low harmonic output. If you are concerned, use a low pass filter with the generator.) The capacitor in the test fixture is then tuned to produce a dip. Use the highest possible amplitude resolution you have in your detector. I go to a 2 dB/division mode with my spectrum analyzer. After an initial dip has been set with the capacitor, use the signal generator to select the lowest dip response. Then use an amplitude control on either the detector or generator to move the observed signal to a cursor line.

Record the signal generator frequency. Then take the test fixture out of the system, realized in my setup by substituting a BNC barrel for the test fixture. The signal will increase at the detector. Increase the attenuation in the step attenuator until the same response at the cursor line is observed. This will provide an attenuation or dip value. Interpolate as needed to obtain data within 0.1 or 0.2 dB. Record this value in the notebook with the previous center frequency.

Finally, unsolder the inductor from the circuit at the point marked with the large X in the figure. Then attach a capacitance measuring meter to measure the C value. I used one of the AADE L/C meters. (Just Google AADE on the web.) The C value is recorded. The F and C data allows calculation of the

effective inductance. The inductor equivalent series resistance can then be calculated from the attenuation, which then leads directly to Q . The equations are included in the EMRFD presentation.

An advantage of this scheme is that the Q value is directly related to the attenuation value, which is relatively easy to determine with an accurate step attenuator. (I use a surplus HP-355C and HP-355D combination.) The detector operates directly on a null point rather than along the slope of an attenuation function where frequency drift can complicate the results. But the method is sensitive to the driving and load impedance at the test fixture. Values other than 50 Ohms will compromise results. It may even be important to actually use 50 Ohm cables; the 52 Ohms of RG-58 might not be close enough. A conservative approach would place a 50 Ohm pad (6 to 10 dB) at the edge of the test fixture.

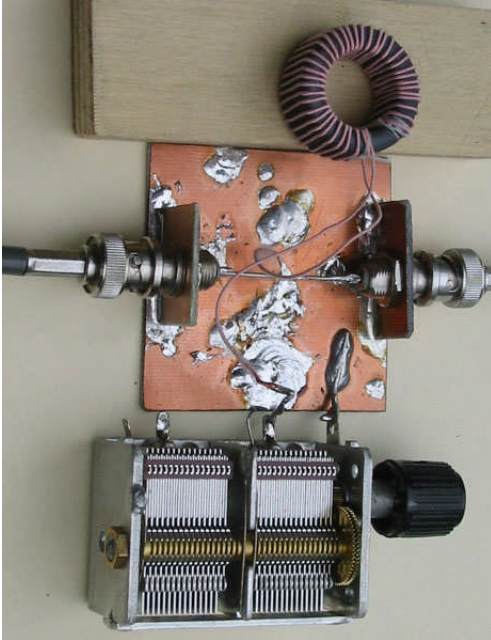

This photo shows the test fixture that we used with the EMRFD scheme. The inductor in this case is a ferrite toroid wound with Litz wire. This variable capacitor is believed to be made by Jackson Brothers, Ltd, from England and is the highest Q variable capacitor we had in our junk box. More on this below.

Comparing the methods.

Most of the measurements we have done in recent times used the EMRFD method. In years past, we would use a Q meter when available, but most often, the 3 dB BW method. Short of a calibrated Q -Meter, the EMRFD scheme is quicker than the 3 dB resonator bandwidth measurement. In one recent case, I measured the Q of an inductor with both methods. The inductor was a basket weave coil, described below. Using the classic 3 dB bandwidth method, the Q was measured as 579 at 1 MHz. Insertion loss was 48 dB for this measurement. The same coil with the same variable capacitor measured $Q=650$ at 1 MHz with the EMRFD scheme. That's about a 10% spread between the two schemes.

The coil used in this experiment was a 5 inch diameter solenoid wound in a basket weave pattern for $L=265$ μH . The wire was 175/46 Litz, which is 175 strands of #46. The coil sat on a piece of plastic suspended on a stack of wood blocks during measurement in an effort to avoid external loads.

Experiments with various coils.



Some of the coils investigated in this study. The basket weave coils were wound with the fixture shown below. The two toroids shown are Amidon FT-114A-61 and used #18 enamel wire or 175/46 Litz wire. The rod is similar to an Amidon R61-050-400 and is wound with 50/46 Litz wire.

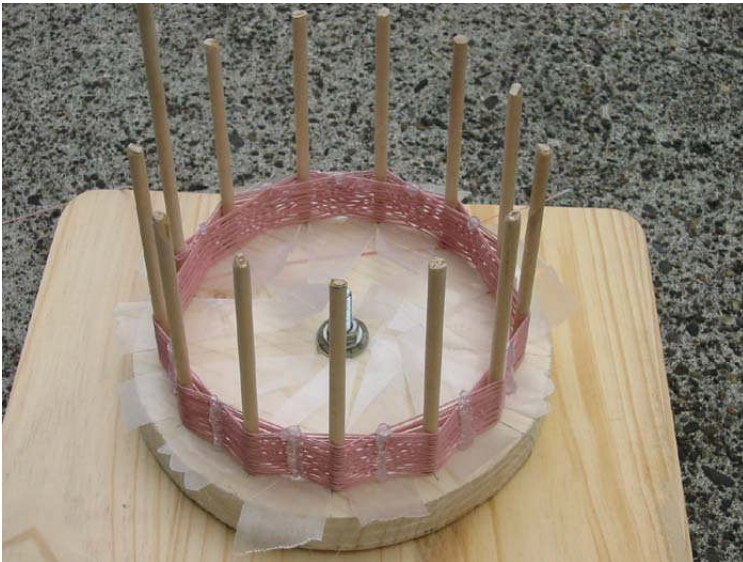

Fixture used to wind basket weave coils. Strips of waxed paper are placed under the coil cross over lines before application of hot melt glue.

Toroid Experiments

Most of the filters I build at HF use toroid cores. Powdered iron cores seem to offer higher Q at HF (3 to 30 MHz) than I can obtain with other practical, reasonable sized forms. The -61 and -63 Ferrite materials from Amidon offer high Q in the MF region from 300 kHz to 3 MHz. Powdered iron can provide high Q, but have such low permeability that the number of turns becomes excessive. So the first experiments I did used ferrite toroids.

Not all of the data collected will be presented here. However, I'll give a few of the data points of interest. There are some surprises.

First, the best toroid I found for BC band use was 38 turns of #18 enamel wire nearly filling a FT-114A-61 core. Inductance was 195 uH on an AADE L/C meter. $Q=383$ at 1 MHz and peaked up to almost 400 at 811 kHz. Q remained well over 300 at both 500 and 1610 kHz.

A slightly more practical and easier to wind coil used a FT-114A-61 form with 41 turns of #22 enamel wire. At 1 MHz, the inductance was 240 uH with a Q of 384. The Q dropped nearly to 300 at the band extremes.

The receiver I was building was to use a variable capacitor with only 188 pF maximum C. So a higher L was needed. I managed to get 56 turns of #22 enamel wire on a FT-114A-61 form for L(AADE) of 449 uH and $Q=344$ at 1 MHz. Q was 316 at 549 kHz and 274 at 1.55 MHz. Although compromised, this seemed a practical coil for a first zero power receiver.

A question that immediately came up was what could be done with Litz wire on toroids. The results were disappointing. 39 turns of 175/46 Litz wire on a FT-114A-61 form yielded $L=244$ uH and $Q=318$ at 1 MHz. The Q improved to 352 down at 550 kHz. A second FT-114A-61 core was wound with 40 turns of smaller 50/46 Litz wire, resulting in $L=248$ uH and $Q=298$ at 1 MHz. Again, low frequency Q improved slightly. My conclusion at this point is that the 175/46 Litz wire is not justified for ferrite toroids, although that conclusion is certainly more general than my data can support. I have not investigated any of the expensive Litz "rope" using over 600 strands of #46 wire. (See later note.)

Variable Capacitor Q (data updated 08Dec08 with more discussion at the end.)

Many of the web sites I read that deal with crystal sets and similar receivers state that the absolute best possible variable capacitors should be used. They then define these as being those capacitors with ceramic insulators, with silver plating being preferred on the metal. Double bearing designs are also recommended. Some sort of special means to minimize resistance related to moving contacts is deemed important. While all of these things are intuitively reasonable, they are not numbers.

The Q measurement schemes I have presented all relate to a determination of **resonator Q**. Actual inductor Q can only be obtained if one knows the Q of the capacitors in a tuned circuit, or if can be established that capacitor Q is very high. The folks building Q meters go to great extremes to optimize the variable capacitor Q within the instrument. (See Kito and Hasegawa, "Measuring Q—Easier and Faster," HP Journal, September, 1970.)

Let me again emphasize that all of the numbers presented here, with all measurement methods, relate to resonator Q. We can calculate capacitor Q only if we independently know the inductor Q.

This still leaves us with the question of what we should be using for variable capacitors, both in our receivers and for Q measurement. To begin an evaluation, I took the highest Q toroid that I had built at the time (38 turns of #18 enameled wire on a FT-114A-61 core) and attached it to various variable and fixed capacitors from my junk box. Measurements were done at or near 1 MHz using the EMRFD measurement scheme. The data, although less than conclusive, is interesting. Here are some results:

Capacitor comparisons, all operated near 100 pF.

1. 107 pF Silver Mica. This consisted of two series connected 214 pF 1% 500 volt units. Resonator Q=341.
2. Mica compression trimmer, 30-300 pF, marked GMA40400, Resonator Q=314.
3. "Jackson Brothers" (that's a guess) dual section, 497 pF/section max, built-in gear drive, Resonator Q=383. **This was the best variable capacitor in my junk box.**
4. TRW four section. This was the most elegant looking capacitor I had in my stash. It came from a Tektronix 191 sine wave generator. Resonator Q=354. An OK cap, but not the best.
5. Collins TCS Transmitter VFO capacitor, built-in gear drive. Resonator Q=357.
6. ARC-5 Receiver variable. (BC-454?, all three sections in parallel yield 47-514 pF) Resonator Q=378.
7. BC-221 capacitor, 13 to 188 pF, Resonator Q=364.
8. Hammarlund single bearing, 150 pF max. Resonator Q=279. (ugh).

Much of the lore seems correct. However, the best measured resonator Q came from the Jackson Brothers dual section, not from antiquity, but from just slightly more recent times. The beautiful TRW capacitor, while good, was not at the top of the list. The aging single bearing capacitor was not expected to be great, and there was no surprise. I was surprised that the Silver Mica capacitors were not at the top. But perhaps these were rejects. Although they were brand new unused capacitors, they were purchased at a surplus emporium and loss may have been the reason they were declared surplus. Additional measurements are called for in this area.

Additional information regarding capacitor measurements is appended at the end of this note.

Litz Wire Connection.

Classic lore suggests that it is vital to solder all strands in a Litz wire bundle at both ends. If one strand is left unsoldered, the argument is that current can no longer flow in that wire, so it will not contribute to the expanded surface area that leads to improved Q with Litz wire.

I had measured less than stellar Q with some 175/46 Litz wire on a toroid form and wondered if perhaps I did not manage to get all of the strands soldered. So I did an experiment while using the mica compression trimmer as the capacitor (poor capacitor choice.) After doing my best to solder all strands by carefully applying rosin flux from a SMT rosin pen, I heated and tinned the ends with an 800 degree tip in my Weller soldering station. The ends looked very good in a visual inspection.

I then started doing Q measurements near 1 MHz. After each one, a few strands of the Litz wire were cut and a 1 inch section was removed near one end. The strands were removed from the capacitor end of the test resonator. Here's a plot of Q from 0 to 152 clipped strands. N was estimated by counting the number of pieces of wire after a clipping operation.

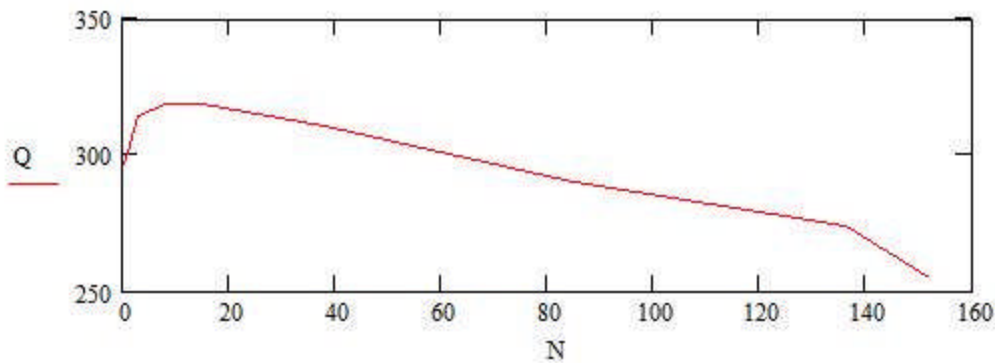

Q versus number of removed strands in a Litz wire toroid. There are 175 total strands in this wire.

This is certainly not a definitive experiment. It should be repeated with a coil where the Litz wire seemed to actually make a difference, and that was not the case with the toroid. However, the classic lore is not supported. But this makes sense after some thought (and some comments from colleague KK7B.) The weak dependence suggests that even though a cut at the end of a wire means that conduction is eliminated at the end of the wire, this does not mean that it is removed from the interior of the coil. Strand to strand capacitance guarantees that similar current will flow in each. The current in each forces the flow to the surface. If a strand is cut, there will still be some current flow in that strand back from the cut. The capacitance between strands connects the strands to those that are still connected at the end.

I hope to repeat this experiment with a different coil and a better resonator capacitor.

The Basket Case

Solenoid coils tend to have the highest Q if the wires are spaced by about 1 wire diameter. This lore is found in Doug DeMaw's book on Ferromagnetic Inductors (Prentice Hall, 1981) and is quoted on the Amidon web page. This rule of thumb is reasonable. The highest inductance will occur with tight spacing. If the spacing increases beyond this, there is a greater chance that some of the magnetic flux from one wire in a coil will escape from the side of a coil and not link to all turns.

If we plot the inductance of a solenoid of constant pitch versus the number of turns, L is proportional to N^2 when N is small. However, the parabolic shape relaxes toward a linear dependence as N becomes large, especially as the length exceeds the diameter. Linear L versus N is akin to adding inductors in series where each one is isolated from the others.

When one turn is directly next to the next turn with no gap, the current flowing in one turn will force some of the current in the next wire to move away. The overall effect produces non-uniform current in the wire surfaces. This is alleviated with a slight spacing between turns. But too much spacing decreases inductance too much.

A classic coil type is the so called basket weave. A couple of coils of this type are shown, along with a coil winding fixture on page 7 of this report. There are an odd number of rods in the winding jig. This means that as we weave the wires among the rods, one turn will not be directly adjacent to the next turn. This makes the coil behave as if it was a solenoid spaced by 1 turn. But there is no real gap, so the coil length, and hence, inductance is the same as a tightly wound one would be.

I had never built a basket weave coil, yet this is one of many designs that the folks describe on the web sites mentioned. So a couple of coils were built. The first used #22 enamel wire. The coil diameter is 5 inches wound on 13 posts with a total of 36 turns. The 1 MHz Q was a poor 244 with Q slowly increasing with frequency. Inductance was 265 uH

A similar coil was then wound with 175/46 Litz wire. Again, inductance was 265 uH. The 1 MHz Q was a spectacular 650. The Q dropped off at both 530 and 1630 kHz, but was OK over most of the range. This is the highest 1 MHz Q I had ever seen at that time. I remember frequent Q values well over 1000 with some helical resonators at 500 MHz, but that is common at UHF.

Ferrite Rod Experiments

The next resonator type to be investigated was the ferrite rod. The only new part that I had around was an Amidon R33-050-750, meaning that it was built from mix 33 type ferrite with a diameter of 0.5 inch and length 7.5 inch. This material has an initial permeability of 800, which is high enough to make me wonder about it as a high Q antenna material. Owing to the high permeability, the number of turns needed should be much less than the 70 turns suggested in the N7FKI paper. I put a layer of paper on the core and then wound 36 turns of #22 enamel wire over the central 3 inches. The inductance was 158 uH. Additional turns would be needed to reach the desired 240 uH.

Then Q was measured. It was a miserable 58.6 at 1 MHz. On the other hand, I did see several local radio stations in the spectrum analyzer display during testing. It may be a viable antenna, but it is not much as a resonator. I didn't even bother changing to Litz wire.

The next experiment was with a junk box ferrite rod. This was a piece that was 3.85 inches long with a diameter of 0.475 inch. After putting a layer of paper on the core, I wound 37 turns of #22 enamel over the inner 2.8 inches. The inductance was 80 uH. A 1 MHz Q measurement was a more respectable 293.

The dimensions of this rod were very close to an Amidon R61-050-400. The inductance constant in the Amidon literature, after conversion, was 43 nH/turn², so the 37 turn winding should have an inductance of 59 uH if it was wound evenly over the total core. My winding was bunched near the center which would increase the inductance a bit, so 80 uH would be reasonable. I concluded that the material is probably -61 mix, or a similar mix with initial permeability of 125, perhaps from a different vendor. I calculated that 65 turns over the same part of the core would yield 250 uH.

Based upon the measurements above, I wound 62 turns of 50/46 Litz wire on a single layer of paper over the junk box rod. The result was a spectacular Q of 610 at 1 MHz. The Q dropped off to 577 at 550 kHz and 500 at 1551 kHz, both still quite respectable. This high Q was a major surprise.

N7FKI has a larger R61-050-750 ferrite rod in his parts box and has offered it for some measurements. That is on the list of "To Do" experiments.

Classic Solenoid Coil

Among the goodies in the N7FKI junk box were some large cylinders that looked like they would work well as coil forms and yield reasonable Q. The outside diameter was 4.2 inches. After earlier coil construction experiments, about 55 feet of Litz wire remained on a spool (purchased on EBay from Paul Cianciolo, W1VLF), so I put solder lugs on each end and wound a coil. The first one had the wires spaced approximately with a 1 wire diameter gap. Measured inductance with the AADE L/C meter was 275 uH. The Q at 1 MHz was 353; OK but disappointing. The winding length was 2.9 inches.

The coil was then rewound with close spacing, resulting in 53.25 turns over a length of 1.52 inches. Inductance with the AADE meter was 378 uH. A 1 MHz Q measurement showed a higher effective L of 419, but with Q=219.

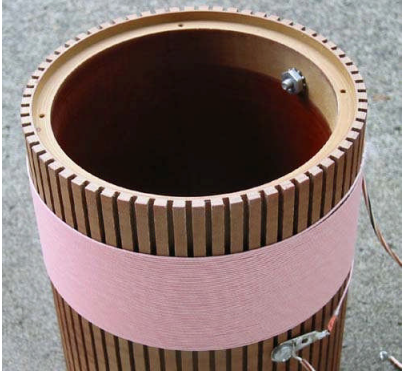

Close spaced solenoid coil.

I have not discussed the self resonant frequency of any of the inductors described in this note. However, it is easily measured by merely inserting the inductor in a 50 Ohm line. The fixture on page 6 of this note can be used. The “through” wire between the BNC connectors is removed and the coil is inserted. The signal generator is then tuned to find the first null frequency. This null is the result of stray parallel C resonating with the inductance to form a trap. The parallel resonant frequency was 4.0 MHz for the close spaced inductor shown in the above photo. This inductor had an inductance of 378 uH, which was measured at about 500 kHz with the AADE L/C meter. This yields an equivalent parallel capacitance of 4.2 pF. Using this and the 378 uH inductance measurement we calculate an effective 1 MHz L of 403 uH. This is still below the value we measured. The AADE number may well be in error because of the coil’s parallel capacitance. Additional number crunching should yield a better model.

Update: 01Dec07

A Spider Coil.

Many of the crystal radio related web sites present information on Spider coils. I picked up a piece of Lexan Polycarbonate at Home Depot and cut it to form a nine segment coil form. The diameter ranged from 4.4 to 6.1 inches. This form was then wound with 39 turns of the 175/46 Litz wire. A photo

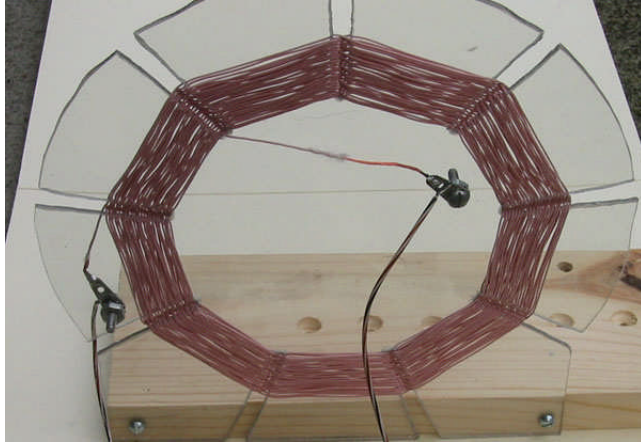

follows.

The inductance was 373 μ H, but the Q results were disappointing at best: 550 kHz, Q=499; 1.002 MHz, Q=474; 1.504 MHz, Q=382. The EMRFD Q measuring scheme was used.

Using Litz Rope.

The initial experiments were encouraging, although I was frustrated in not having achieved higher Q values. A review of many sites on the web quoted "Q over 1000" as if it was to be expected. One of the most informative web sites that I found was from Europe, <http://www.crystal-radio.eu/enlctest.htm>. He built numerous coils and then did careful Q measurements. Many of his measurements were consistent with mine. There was one central theme that emerged: If Q in excess of 1000 is desired, it is probably achievable only with Litz wire using many more strands than the 175 that I had used. Specifically, the wire that really made the difference in the measurements from Europe was 660/46 Litz. This is 660 strands of #46 wire. I've seen this stuff referred to as "Litz Rope," although that term is often reserved for the bundles that are up to two inches in diameter. The 660/46 wire is manufactured by Kerrigan-Lewis. They will sell to individuals, but have a 2 pound minimum. That's a lot of rope. You can find smaller pieces of this wire for sale on the web, but with a high price tag.

Then my experiments expanded to the next level. This was the result of an unexpected package that showed up in my mail box. I opened this offering to discover a 54 foot piece of the 660/46 Litz rope, plus a most interesting letter. My benefactor was Steve, AA7U. Steve's letter also mentioned the coil form that many of the crystal set guys use, a 4.5 inch OD coupler for large PVC pipe. I quickly purchased some. The part was found in the bins at Home Depot where it is their part number 405* and is marked "4 IN COUPLING HUBXHUB" and "(STYRENE)". The form cost was just over \$1. Steve had done careful measurements of coils using this form and 660/46 Litz Rope.

I quickly wound the coil shown below.

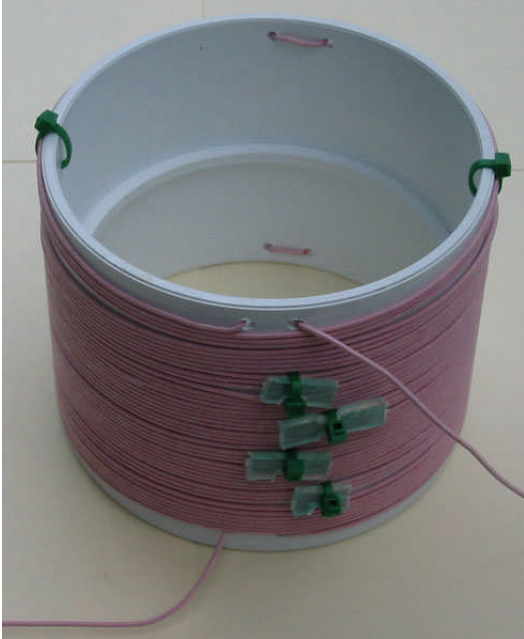

The photo does not really tell us about coil length. This coil has the 44 turns spaced to occupy 3 inches of the 3.6 inch form length. The wire is held in place at the ends with holes in the form. Small cable ties are then used to keep the windings from moving. I wanted to preserve the integrity of the Rope for additional experiments, so did not want to apply any glue. I cut some small strips of Plexiglas with filed notches. These strips are then placed over a pair of holes drilled in the form so that three wire turns are covered. The cable tie is then inserted.

The results were outstanding; finally, $Q > 1000$. The details with the EMRFD Q measuring scheme:

F=550 kHz Q=1199

1011 kHz Q=1375

1600 kHz Q= 973

Steve's results with a similar coil were 1276, 1426, and 1129 at approximately the same frequencies. Steve used a traditional 3 dB bandwidth measurement to establish Q, but with the coil tuned by the variable capacitor in a HP4342A Q meter. That Q meter stops at values of 1000.

Although I was pleased to have finally reached a Q goal, the measurement correlation was of equal significance to me. This data is further validation of the EMRFD Q measurement scheme. The Q values that are slightly lower than those that Steve obtained can be attributed to losses in the variable capacitor I used and to experimental error. These values are consistent with those reported in the crystal-radio.eu web site listed above.

Recent examination of capacitor Q. (December 8, 2008.)

The earlier information regarding variable capacitor Q was confusing. That info, starting on page 8, has been modified to emphasize that my measurements are of **total resonator Q**. Although I have yet to do additional measurements, I did a few calculations that are illuminating.

We begin with analysis to derive a suitable formula. This is shown below in a MathCad work sheet.

Regarding the Q of an inductor where we measure just the resonator.

We may define the Q of a component as the ratio of the reactance at a frequency to the resistance, also measured at the same frequency. This is the usual model that is used.

$$Q_i = \frac{X_i}{R_i} \quad \text{where the "i" subscript is L or C, indicating an inductor or capacitor. This becomes}$$

$$R_i = \frac{X_i}{Q_i} \quad \text{with } i=L \text{ or C.}$$

We now place the inductor and capacitor in series. They resonate at a frequency f with the usual resonance condition. We will evaluate Q values at this resonance, which is defined by:

$$X_L = X_C \quad \omega \cdot L = \frac{1}{\omega \cdot C} \quad \text{where} \quad \omega = 2 \cdot \pi \cdot f$$

$$\text{The total resistance is} \quad R = \frac{\omega \cdot L}{Q_L} + \frac{1}{Q_C \cdot \omega \cdot C}$$

The Q of the resonator will merely be the value with this R, but with the assumption that all loss is within the inductor. Hence,

$$Q_{Res} = \frac{X_L}{R} = \frac{\omega \cdot L}{\left(\frac{\omega \cdot L}{Q_L} + \frac{1}{Q_C \cdot \omega \cdot C} \right)}$$

$$Q_{Res} = \frac{1}{\frac{1}{Q_L} + \frac{1}{Q_C \cdot \omega^2 \cdot L \cdot C}}$$

We divide top and bottom by ωL to obtain

Because of resonance, this becomes

$$Q_{Res} = \frac{1}{\frac{1}{Q_L} + \frac{1}{Q_C}} \quad \text{That is, Q values combine as resistors in parallel.}$$

Assume that we know an inductor Q. The capacitor Q from a resonator measurement is then

$$Q_C = \frac{Q_{Res} \cdot Q_L}{Q_L - Q_{Res}}$$

Note that Q_L cannot equal resonator Q. Moreover we must have $Q_L > Q_{Res}$ to have a positive capacitor Q.

[MathCad work sheet showing analysis.](#)

Armed with the final formula in the above sheet, we can examine the capacitor Q data in more detail. We did this with Excel, beginning with a summary of the data and a "plot" showing the results. The plot is just a bar chart and serves only to illustrate that most of the results are close to each other. Only one resonator Q was below 300, the result of a single bearing variable capacitor. None of the resonator Q values exceeded 400. This is shown below.

	A	B	C	D	E	F	G	H	I	J
1	Capacitor Q Determinations. L=38t #18 enameled wire on FT-114A-61 toroid.									8-Dec-08
2	All C close to 100 pF. The data has been sorted with descending Q-resonator.									
3										
4		Capacitor				N	Measured Resonator Q			
5										
6		Jackson Brothers				1	383			
7		ARC-5/BC-454				2	378			
8		BC-221 cap				3	364			
9		TCS Transmitter VFO				4	357			
10		TRW				5	354			
11		107 pF SM				6	341			
12		compression trimmer				7	314			
13		Harrmarlund single bearing				8	279			
14										
15										
16										
17										
18										
19										
20										
21										
22										
23										
24										
25										
26										
27										
28										
29										

Resonator Q Values

Capacitor Type	Measured Resonator Q
1	383
2	378
3	364
4	357
5	354
6	341
7	314
8	279

Sorted and plotted Capacitor impact on Resonator Q.

Having generated the bar chart, we proceeded to use the spread sheet to do some “what if” investigations. The first analysis assumed that our best capacitor was very good, so the highest resonator Q that we measured was almost the inductor Q value. If that really was the case, we can then calculate capacitor Q values. This case is at the top of the following page with QL=385.. After that, we assumed even higher inductor Q values and calculated the resulting capacitor Q results. See the next page.

30 Assume that the "best" capacitor is virtually perfect. Hence, the resonator Q we then measured will be the Q of the inductor.

31 So, let's set the inductor Q = 385 and calculate the related capacitor Q values. The formula is:

$$Q_c = \frac{Q_{Res} \cdot Q_L}{Q_L - Q_{Res}}$$

	N	Q-reson	Q-L	Q-C		Q-reson	Q-L	Q-C		Q-reson	Q-L	Q-C	
38	Jackson Brothers	1	383	385	73727.5								
39	ARC-5/BC-454	2	378	385	20790								
40	BC-221 cap	3	364	385	6673.33								
41	TCS Transmitter VFO	4	357	385	4908.75								
42	TRW	5	354	385	4396.45								
43	107 pF SM	6	341	385	2983.75								
44	compression trimmer	7	314	385	1702.68								
45	Harrmarlund single bearing	8	279	385	1013.35								
47		N	Q-reson	Q-L	Q-C		Q-reson	Q-L	Q-C		Q-reson	Q-L	Q-C
48	Jackson Brothers	1	383	400	9011.76		383	410	5815.93		383	420	4347.57
49	ARC-5/BC-454	2	378	400	6872.73		378	410	4843.13		378	420	3780
50	BC-221 cap	3	364	400	4044.44		364	410	3244.35		364	420	2730
51	TCS Transmitter VFO	4	357	400	3320.93		357	410	2761.7		357	420	2380
52	TRW	5	354	400	3078.26		354	410	2591.79		354	420	2252.73
53	107 pF SM	6	341	400	2311.86		341	410	2026.23		341	420	1812.91
54	compression trimmer	7	314	400	1460.47		314	410	1341.04		314	420	1244.15
55	Harrmarlund single bearing	8	279	400	922.314		279	410	873.206		279	420	831.064
58			Q-reson	Q-L	Q-C		Q-reson	Q-L	Q-C		Q-reson	Q-L	Q-C
59			383	430	3504.04		383	440	2956.49		383	450	2572.39
60			378	430	3125.77		378	440	2682.58		378	450	2362.5
61			364	430	2371.52		364	440	2107.37		364	450	1904.65
62			357	430	2102.88		357	440	1892.53		357	450	1727.42
63			354	430	2002.89		354	440	1811.16		354	450	1659.38
64			341	430	1647.53		341	440	1515.56		341	450	1407.8
65			314	430	1163.97		314	440	1096.51		314	450	1038.97
66			279	430	794.503		279	440	762.484		279	450	734.211

Spreadsheet showing a variety of capacitor Q values resulting from assumed inductor Q (in blue) and the measured resonator Q values (in red.)

The results are interesting. If the best measured Q is indeed mostly that of the inductor, we see that most of the capacitor Q values are high with even the worst still over 1000. If we slowly allow the inductor Q to increase in our "thought experiment," the capacitor Q values begin to drop. However, the best of the lot are still several thousand. While none of this conjecture is really hard data, it certainly makes us feel more comfortable with inductor Q values close to 400 and that it is valid to assume high capacitor Q.

Examination of the central equation is revealing. It is clear that if the inductor Q becomes much higher, we will be able to obtain much better data about the capacitors. The most recent inductor built has a Q that is three times higher than the one used for the capacitor difference. The next experiment is obvious and will be in the next update to this note.

Acknowledgements

Thanks go to my son Roger, KA7EXM, to colleagues Rick, KK7B, and Bob, N7FKI, for numerous discussions. Bob also provided some critical parts for my experiments. Special thanks go to Steve Ratzlaff, AA7U, for the crucial Litz wire that so greatly enhanced the experiments.