

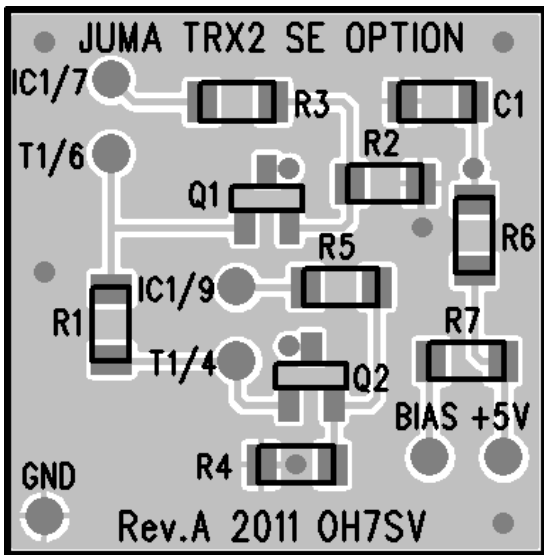

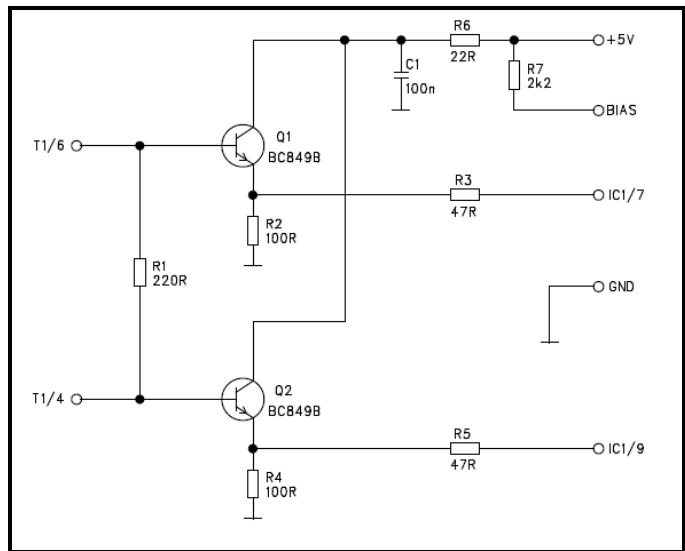

# JUMA TRX2 Spur Elimination Option assembling instruction 2011-08-16 OH7SV



JUMA TRX2 SE OPTION layout



JUMA TRX2 SE OPTION schematics

JUMA-TRX2 SE OPTION board part list for PCB Rev. A, update 2011-08-16				
Part number	Value / type	Qty	Description	Picture
PCB	JUMA TRX2 SE OPTION PCB	1	PCB	
R6	22R	1	Resistor SMD 1% size 1206	
R3 R5	47R	2		
R2 R4	100R	2		
R1	220R	1		
R7	2k2	1		
C1	100n	1	Ceramic SMD capacitor size 1206 X7R	
Q1 Q2	BC849B	2	NPN transistor SOT-23	
Tinned copper wire	Diameter 0.5mm, length 0.5m	1	Prepare 7 pcs L-shaped 50mm/1mm wires	

## Assembling instructions

1. Solder the SMD components to the SE OPTION board according to the part list
2. Remove resistors R1, R106 and R107 from TRX2 Main board
3. Prepare 7 pcs L-shaped tinned copper wire with approximately length of 50mm/1mm
4. Solder the wires vertically with L-shape pointing to the main board to both pads of R1, to both pads of R106, to both pads of R107 and to transformer T1 pin 2 (GND)

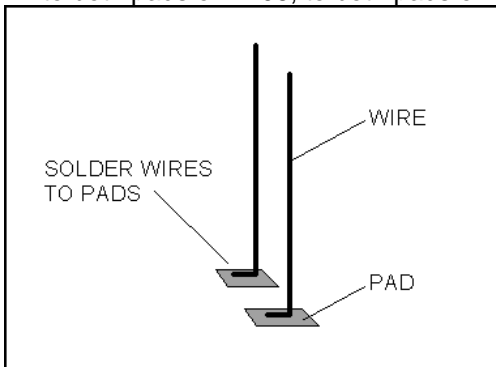

Wire soldering principle

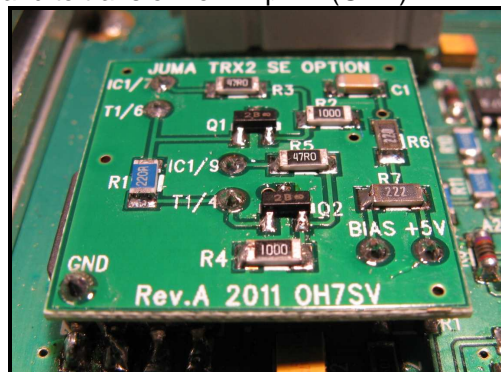

JUMA TRX2 SE OPTION installed

5. Insert SE OPTION gently to the wires and align it down to the transformer T1 level
6. Solder the wires to the option board pads
7. Cut out the extra wires
8. Check normal operation and the spur attenuation
9. Recheck the S-meter indication and transmit power