



MOTOROLA

GM1200E

Mobile Radio

Detailed Service Manual

68P64115B15

CAUTION

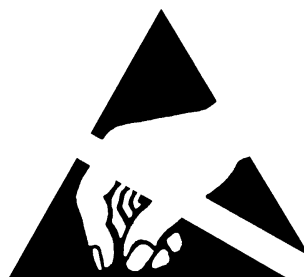

ELECTROSTATIC SENSITIVE DEVICES

PRECAUTIONS SHOULD BE TAKEN TO MINIMIZE THE RISK OF DAMAGE BY ELECTROSTATIC DISCHARGE TO ELECTROSTATIC SENSITIVE DEVICES (ESDs).

ANY DEVICES EMPLOYING METAL OXIDE SILICON (MOS) TECHNOLOGY ARE PARTICULARLY SUSCEPTIBLE.

CIRCUIT DIAGRAMS MARKED WITH THE ABOVE SYMBOL INDICATE ELECTRONIC CIRCUITS (PECs) FOR WHICH ESD HANDLING PRECAUTIONS ARE NECESSARY.

THE USER SHOULD REFER TO BS5783, 1984: HANDLING OF ELECTROSTATIC SENSITIVE DEVICES. THIS BRITISH STANDARD SUPERSEDES DEF STAN 59-98, ISSUE 2.

WARNING

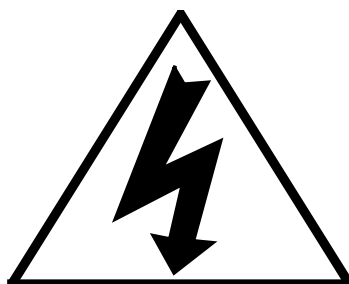

SAFETY WARNINGS

THE ELECTRICAL POWER USED IN THIS EQUIPMENT IS AT A VOLTAGE HIGH ENOUGH TO ENDANGER LIFE.

BEFORE CARRYING OUT MAINTENANCE OR REPAIR, PERSONS CONCERNED MUST ENSURE THAT THIS EQUIPMENT IS ISOLATED FROM THE ELECTRICAL SUPPLY AND TESTS ARE MADE TO ENSURE THAT ISOLATION IS COMPLETE.

WHEN THE SUPPLY CANNOT BE ISOLATED, MAINTENANCE AND REPAIR MUST BE UNDERTAKEN BY PERSONS WHO ARE FULLY AWARE OF THE DANGERS INVOLVED AND WHO HAVE TAKEN ADEQUATE PRECAUTIONS TO PROTECT THEMSELVES.

COMPONENTS CONTAINING BERYLLIUM OXIDE ARE USED IN THIS EQUIPMENT. DUST FROM THIS MATERIAL IS A HEALTH HAZARD IF INHALED OR ALLOWED TO COME INTO CONTACT WITH THE SKIN.

GREAT CARE MUST BE TAKEN WHEN HANDLING THESE COMPONENTS WHICH MUST NOT BE BROKEN OR SUBJECTED TO EXCESSIVE HEATING. DEFECTIVE COMPONENTS MUST BE DISPOSED OF IN ACCORDANCE WITH CURRENT INSTRUCTIONS.

LEAD ACID BATTERIES MAY BE FITTED AS THE STANDBY BATTERY. CARE MUST BE TAKEN WHEN REMOVING OR INSTALLING THESE BATTERIES TO:

1. ENSURE THAT THE TERMINALS ARE NOT SHORTED TOGETHER.
2. PREVENT SPILLAGE OF THE CORROSIVE ELECTROLYTE.

Detailed Service Manual

Contents

Chapter

1.0 Introduction

Gives a brief introduction into the manual and the service policy.

2.0 Control Head - Level 3 Information

Provides level 3 service information on the Display/Keypad Control Head (K6) detailed in the following chapters:

- 2.1 Introduction/Theory of Operation
- 2.2 PCB/Schematic Diagrams and Parts Lists

3.0 UHF/VHF Radio - Level 3 Information

Provides level 3 service information on the UHF/VHF radio detailed in the following chapters:

- 3.1 Introduction/Theory of Operation
- 3.2 PCB/Schematic Diagrams and Parts Lists

Chapter 1

Introduction

Table of Contents

Paragraph		Page
1.0	Introduction	1
2.0	Scope of Manual	1
3.0	How to Use This Manual	1
4.0	Warranty and Service Support	1
4.1	Warranty Period	1
4.2	After Warranty Period	2
4.3	Piece Parts	2
4.4	Technical Support	2
4.5	Associated Documentation	2

1.0 Introduction

This chapter outlines the scope and use of the detailed service manual and provides an overview of the warranty and service support.

2.0 Scope of Manual

This manual is intended for use by experienced technicians familiar with similar types of equipment. It contains level 3 service information required for the equipment described and is current as of the printing date. Changes which occur after the printing date maybe incorporated by a complete Detailed Service Manual revision or alternatively as additions, for example, to Band Specific information.

3.0 How to Use This Manual

The detailed service manual contain an introductory chapter giving information on warranty and support. Chapter 2 contains level 3 service information for the control head . Chapter 3 details level 3 service information for the radios in band specific sub-chapters each containing theory of operation and schematics/parts lists. Refer to the Table of Contents for a general overview of the manual.

4.0 Warranty and Service Support

Motorola offers long term support for its products. This support includes full exchange and/or repair of the product during the warranty period, and service/ repair or spare parts support out of warranty. Any "return-for-exchange" or "return-for-repair" by an authorised Motorola Dealer must be accompanied by a Warranty Claim Form. Warranty Claim Forms are obtained by contacting an Authorised Motorola Dealer.

4.1 Warranty Period

The terms and conditions of warranty are defined fully in the Motorola Dealer or Distributor or Reseller contract. These conditions may change from time to time and the following notes are for guidance purposes only.

In instances where the product is covered under a "return for replacement" or "return for repair" warranty, a check of the product should be performed prior to shipping the unit back to Motorola. To ensure the product has been correctly programmed or has not been subjected to damage outside the terms of the warranty.

Prior to shipping any radios back to the appropriate Motorola warranty depot, please contact Customer Services. All returns must be accompanied by a Warranty Claim Form, available from your Customer Services representative. Products should be shipped back in the original packaging, or correctly packaged to ensure no damage occurs in transit.

4.2 After Warranty Period

After Warranty period, Motorola continues to support products in two ways.

Firstly, Motorola's Radio Parts and Service Group (RPSG) offer a repair service to both end users and dealers at competitive prices.

Secondly, RPSG supplies individual parts and modules that can be purchased by dealers who are technically capable of performing fault analysis and repair.

4.3 Piece Parts

Some replacement parts, spare parts, and/or product information can be ordered directly. If a complete Motorola part number is assigned to the part, it is available from Motorola Radio Parts and Service Group (RPSG). If a generic part is listed or only a part description is listed, the part is not normally available from Motorola. If a parts list is not included, this generally means that no user-serviceable parts are available for that kit or assembly.

All orders for parts/information should include the complete Motorola identification number. All part orders should be directed to your local RPSG office.

Head Office
Motorola G.m.b.H.
European Parts Department
65232 Taunusstein
Germany

4.4 Technical Support

Motorola Product Services is available to assist the dealer/distributors in resolving any malfunctions which may be encountered. Initial contact should be by telephone whenever possible. When contacting Motorola Technical Support, be prepared with the product model number and the unit's serial number.

4.5 Associated Documentation

<i>Publication Number</i>	<i>Description</i>
ENLN4051A	GM1200E Product Manual (with Level 1/2 repair information)
ENLN4052A	GM1200E Produkthandbuch
ENLN4053A	Manuel de Produit GM1200E
68P64117B01	Shared Mobile Radio Systems (SMR) using MPT1327 A System Integrators Cookbook
68P02900X57-A	Data Application Notes for 1200 Series Radios

Chapter 2

Control Head - Level 3 Information

Table of Contents

Chapter

- 2.1 Introduction/Theory of Operation**
- 2.2 PCB/Schematic Diagram and Parts List**

Chapter 2.1

Introduction/Theory of Operation

Table of Contents

Paragraph	Page
1.0 Overview	1
2.0 Exploded View Diagram	2
3.0 Theory of Operation	2
3.1 General	2
3.2 Power Supplies	3
3.3 Voltage Regulator Circuit	3
3.4 Power On / Off	3
3.5 Microprocessor Circuit	4
3.6 Serial Peripheral Interface (SPI)	4
3.7 Keypad Keys	5
3.8 Status LED and Back Light Circuit	5
3.9 Liquid Crystal Display (LCD)	5
3.10 Microphone Connector	6
3.11 Electrostatic Transient Protection	6

1.0 Overview

128 Channel, Keypad/Display Radio Control Head (Model K6)

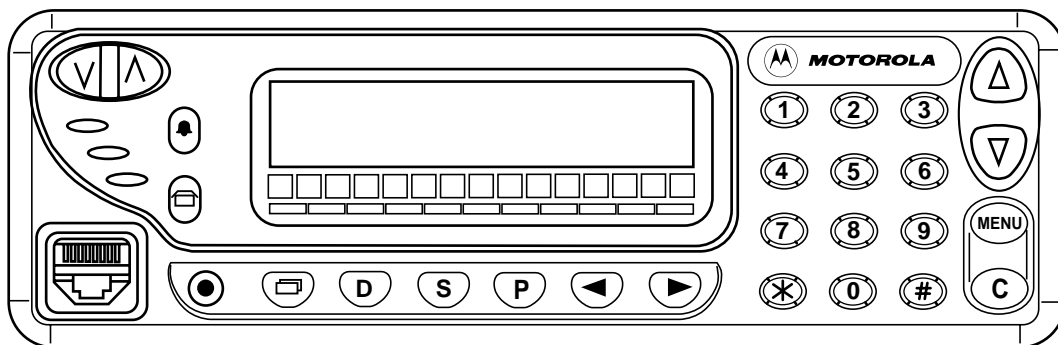

The features of the radio control head are as follows:

- On/Off Button
- Rocker type Volume Up/Down Control
- Volume Level Indicators (RSSI)
- Backlit Liquid Crystal Display (LCD) with display icons to show call progress and status
- Up/Down scrolling keys for the display
- Left/Right scrolling keys for the display
- 3 x 4 CCITT Keypad
- Clear/Edit Button
- Status Button
- Data Button
- Base Call Button
- 3 LED's (Red, Yellow and Green)
- Microphone Socket
- Menu Button
- Personality Button
- Call In Absence Button
- External Alarm Button

2.0 Exploded View Diagram

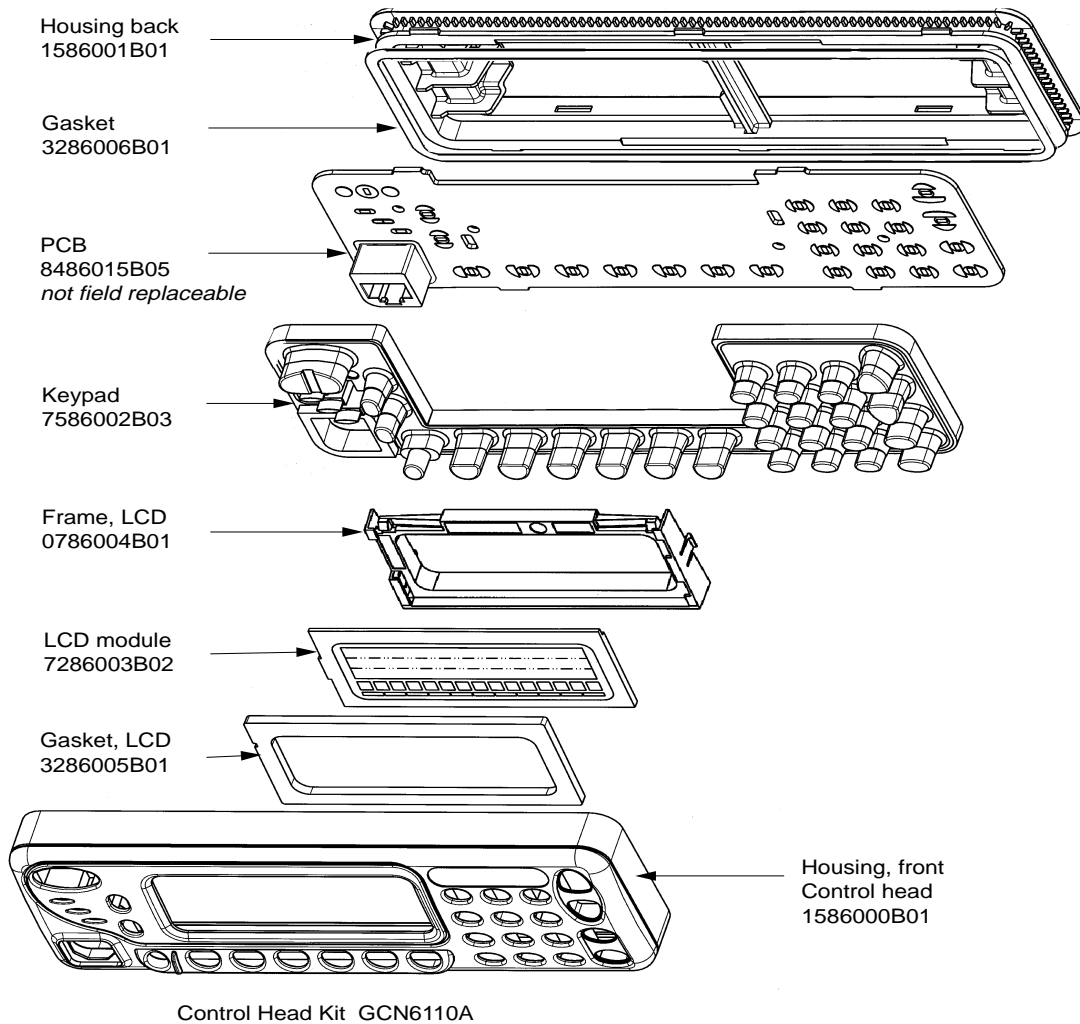

LAPD0008-2

3.0 Theory of Operation

3.1 General

The control head contains the microphone connector, several buttons to operate the radio, several indicator Light Emitting Diodes (LED) to inform the user about the radio status and a Liquid Crystal Display (LCD) with 19 pre - defined symbols, 11 bars and a 24x120 dot matrix for graphical or alpha - numerical information e.g. channel number, select code, call address name. To control the LEDs and the LCD, and to communicate with the host radio, the control head uses the Motorola 68HC11E9 or 68HC11E20 (dependent on the used character set) microprocessor.

3.2 Power Supplies

The power supply to the control head is taken from the host radio FLT A+ voltage via connector J0901 pin 2. The voltage FLT A+ is at battery level and is used for the LEDs, the back light, to power up the radio via On / Off button and to supply the voltage regulator circuit. The regulator circuit provides the stabilized +5 volt which is used for the microprocessor circuit, the display, the display driver and the keypad buttons. The voltage +5V USW also provided by the regulator circuit is used to buffer the internal RAM of the microprocessor (U0901). The regulated +5V taken from the host radio via connector J0901 pin 10 (line +5V SOURCE) is only used to switch on or off the voltage regulator in the control head.

3.3 Voltage Regulator Circuit

Voltage regulator U0891 provides 5V for the control head. The supply voltage FLT A+ for the voltage regulator is fed via parallel resistors R0893/4 and dual diode D0891 to pin 8 of U0891. The +5 volt output is switched on and off by the host radio's 5 volt source via line +5V SOURCE and control transistor Q0891. When the host radio is switched off the voltage on line +5V SOURCE is at ground level and switches off transistor Q0891. Pull up resistor R0892 pulls input SHUTDOWN (pin 3) of the voltage regulator U0891 to FLT A+ level and switches off the output of U0891 (pin 1). When the host radio is switched on the voltage on line +5V SOURCE of about +5 volts switches on transistor Q0891 which in turn pulls input SHUTDOWN (pin 3) to ground and switches on the output of U0891. Input and output capacitors (C0892 / C0893 and C0895 - C0896) are used to reduce high frequency noise and provide proper operation during battery transients. Diode D0891 prevents discharge of C0893 by negative spikes on the FLT A+ voltage. This regulator provides a reset output (pin 5) that goes to 0 volts if the regulator output goes out of regulation. This is used to reset the microprocessor (U0901) and the display driver (U0902) to prevent improper operation.

The voltage +5V USW derived from voltage FLT A+ is stabilized using resistor R0896 and diode VR0891. This voltage is used to buffer the microprocessor's internal RAM. C0898 allows the battery voltage to be disconnected for a couple of seconds without losing RAM parameters. Diode D0892 prevents radio circuitry from discharging this capacitor. The +5V at the second anode of D0892 speeds up charging of C0898 when the host radio is turned on by a high level at the ignition input while the supply voltage is applied to the radio. This prevents the microprocessor from accidentally entering bootstrap mode.

3.4 Power On / Off

The On/Off button when pressed switches the radio's voltage regulators on by pulling ON OFF CONTROL to high via D0931 and connects the base of Q0932 to FLT A+. This transistor pulls the line ANALOG 3 low to inform the μ P that the On/Off button is pressed. If the radio is switched off, the μ P will switch it on and vice versa. If the On/Off button is pressed and held while the radio is on, the software detects a low state on line ANALOG 3 and switches the radio off. If the radio is switched on either manually or automatically its +5V source switches on the control head voltage regulator U0891 via line +5 SOURCE and transistor Q0891 and the control head microprocessor starts execution.

3.5 Microprocessor Circuit

The control head uses the Motorola 68HC11E9 or 68HC11E20 (dependent on the used character set) microprocessor (μ P) (U0901) to control the LEDs, the LCD and to communicate with the host radio. RAM and ROM are contained within the microprocessor itself.

The clock generator for the microprocessor can use two different configurations:

1. The oscillator inside the microprocessor (U0901) along with a 4 MHz ceramic resonator (Y0922) and R0920 generate the clock.
2. The oscillator inside the microprocessor (U0901) along with some external components (C0922-C0924, L0921, R0922, Y0921) generate the 7.9488 MHz clock. Q0921 is used to alter the clock frequency slightly under software control if there is a possibility of harmonics of this clock source interfering with the desired radio receive frequency.

The microprocessor E9/E20 (U0101) contains internal 12 (E9) or 20 (E20) Kbytes ROM, 512 (E9) or 768 (E20) bytes SRAM and 512 bytes EEPROM.

The microprocessor's RAM is always powered to maintain parameters such as the last operating mode. This is achieved by maintaining 5V at U0901-25. Under normal conditions, when the radio is off +5V USW is formed by FLT A+ via D0892. C0898 allows the battery voltage to be disconnected for a couple of seconds without losing RAM parameters. Diode D0892 prevents radio circuitry from discharging this capacitor.

There are 8 analogue to digital converter ports (A/D) on U0901. They are labelled within the device block as PE0-PE7. These lines sense the voltage level ranging from 0 to 5V of the input line and convert that level to a number ranging from 0 to 255 which can be read by the software to take appropriate action.

U0901-22 is the high reference voltage for the A/D ports on the μ P. Resistor R0927 and capacitor C0925 filter the +5V reference. If this voltage is lower than +5V the A/D readings will be incorrect. Likewise U0901-21 is the low reference for the A/D ports. This line is normally tied to ground. If this line is not connected to ground, the A/D readings will be incorrect.

The MODB (U0901-25) input of the μ P must be at a logic '1' for it to start executing correctly. The XIRQ (U0901-45) and the IRQ (U0901-46) pins should also be at a logic '1'.

The microprocessor can determine the keypad type used, by reading the voltages at pins 63 and 64. Connections JU0911 and JU0912 are provided by the individual keypads.

Capacitors C0927 and C0928 serve to filter out any AC noise on +5V line at U0901.

3.6 Serial Peripheral Interface (SPI)

The host radio (master) communicates to the control head μ P (slave) through its SPI port (BUS). This port consists of SPI TRANSMIT DATA (SPI MOSI) (U0901-52), SPI RECEIVE DATA (SPI MISO) (U0901-51), SPI CLK (SPI CLCK BUF) (U0901-53) and a control head select line (CNTL HD CE) (U0901-54). This BUS is a synchronous bus, in that the timing clock signal SPI CLCK is sent while SPI data (SPI TRANSMIT DATA or SPI RECEIVE DATA) is sent. Therefore, whenever there is activity on either SPI TRANSMIT DATA or SPI RECEIVE DATA there should be a uniform signal on SPI CLK. The SPI TRANSMIT DATA is used to send serial from the host radio to the control head μ P, and SPI RECEIVE DATA is used to send data from the control head μ P to the host radio.

When the host radio needs to communicate to the control head μP it brings the control head select line (CNTL HD CE) to a logic '0' and then sends the proper data and clock signals. After the data has been sent the control head select line is returned to a logic '1'. When the control head μP wants to communicate to the host radio the μP brings request line CNTL HD REQ to a logic '0' by switching on transistor Q0931 via μP pin 11. The host radio then starts communication by activating the control head select line (CNTL HD CE), sending the clock signal and sending data via SPI MOSI or receiving data via SPI MISO and buffer U0931-1.

3.7 Keypad Keys

The control head keypad is a 26 - key keypad. All keys are configured as 6 analogue lines (AN 0 - 5) to the control head μP . Lines AN 0 - 3 each control four keys, lines AN 4, 5 each control five keys. The voltage on the analogue lines varies between 0V and +5V depending on which key has been pressed. If a button is pressed, it will connect one of the 6 lines AN 0 - 5 to a resistive voltage divider R0807 - R0811 connected to +5V. The voltages of the lines are A/D converted inside the μP (ports PE 0 - 5) and specify the pressed button.

3.8 Status LED and Back Light Circuit

All the indicator LEDs (D0881 - D0884) are driven by current sources Q0881 - Q0883. To change the LED status the host radio sends a data message via SERIAL PERIPHERAL INTERFACE (SPI) to the control head μP . The control head μP determines the LED status from the received message and switches the LEDs on or off via pins 5, 6, 7. The LED status is stored in the μP 's memory. The LED current is determined by the resistor at the emitter of the respective current source transistor.

The backlight for the LCD and the keypad is controlled by the host radio the same way as the indicator LEDs using μP pins 8, 9, 10. The keypad backlight current is drawn from the FLT A+ source and controlled by transistor Q0851. The current flowing through the LEDs cause a proportional voltage drop across the parallel resistors R0861, R0862. This voltage drop is amplified by the op-amp U0831-2. U0831-2 and Q0852 form a differential amplifier. The voltage difference between the base of Q0852 and the output of U0831-2 determines the current from the base of the LED control transistor Q0851 and in turn the brightness of the LEDs. The μP can switch the LEDs on and off by a logic high or low level at the port connected to the base of Q0852. If the base of Q0852 is at ground level, Q0852 is switched off and no current flows through Q0851 and the LEDs. If the μP port changes to +5V a current flows through Q0852 and in turn through Q0851 causing the LEDs to turn on and a rising voltage drop across R0861, R0862. The rising voltage causes the output of the op-amp to rise and to reduce the base to emitter voltage of Q0852. This decreases the current of Q0852 until the loop has settled. The backlight for the LCD uses a similar circuit. By using two μP ports (pin 8, 9) and different weighting resistors R0837 and R0838 the base of Q0832 can be set to four different voltage levels. This allows to switch the LEDs off or to select among three levels of brightness.

3.9 Liquid Crystal Display (LCD)

The LCD module U0902 consists of the display and the display driver. The display is a single layer super twist nematic (STN) LCD display. It has a dot matrix of 24 x120 dots for displaying graphics and alpha - numerical information, a line with 19 pre - defined icons below the dot matrix and line with 11 bars below the icon line. Six of the bars can be used to display the status of the keys located below.

The display driver is fixed on the flex which connects the display to the PC board. The driver contains a data interface to the μ P, an LCD segment driver, an LCD power circuit, an oscillator, data RAM and control logic. At power up the driver's control logic is reset by a logic '0' at input RES (U0902-9). Resistor R0946 sets the driver's internal oscillator to about 18 kHz. By connecting U0902 pin 12 to +5V the driver's μ P interface is configured to accept 8 bit parallel data input (U0902-D0-D7) from the control head μ P (U0901 port PC0-PC7). Pin 15 connected to +5V sets the 6800 μ P control mode.

To write data to the driver's RAM the μ P sets chip select (U0902-14) to logic '1' via U0901-59 and R/W (U0902-17) to logic '0' via U0901-56. With input A0 (U0902-16) set to logic '0' via U0901-58 the μ P writes control data to the driver. Clock signal E at pin 18 generated by μ P pin 57, shifts 8 bit parallel data into the driver. Control data includes the RAM start address for the following display data. With input A0 set to logic '1' the μ P then writes the display data to the display RAM. When data transfer is complete the μ P terminates the chip select and the clock activities.

The voltage supply for the display is provided by the display driver power circuit. This circuit consists of a voltage multiplier, voltage regulator and a voltage follower. To use an external voltage supply the built-in power circuit can be turned off by a control command. The settings of the inputs T1 (U0902-36) and T2 (U0902-35) select among the various functions of the power circuit. With both inputs set to ground level by resistors R0955 and R0956 the voltage multiplier, the voltage regulator and the voltage follower are activated and no external voltage supply is required for the LCD. The external capacitors C0951 - C0953 configure the multiplier to triple the supply voltage. If R0957 is used instead of C0952 the multiplier doubles the supply voltage. In this configuration the multiplier output VOUT (U0902-42) supplies a voltage of -5V ($2^* -5V$ below VDD). The multiplied voltage VOUT is sent to the internal voltage regulator. To set the voltage level of the regulator output V5 (U0902-43) this voltage is divided by the resistors R0958 and R0959 and feed back to the reference input VR (U0902-44). In addition the regulator output voltage V5 can be controlled electronically by a control command sent to the driver. With the used configuration the voltage V5 is about -3V. The voltage V5 is resistively divided by the driver's voltage follower to provide the voltages V1 - V4. These voltages are needed for driving the liquid crystals. The driver circuit can be configured to use externally generated voltages for VOUT and V1 - V5. In this case the +5V supply voltage is multiplied by the μ P (U0901-62) along with the multiplier circuit D0911, C0911, C0912, R0911 and R0913. The μ P provides a square wave signal at pin 62 to drive the multiplier circuit. The voltages V1-V4 are generated from VOUT or V5 by the resistive divider R0941 - R0945 and supplied to the driver ports V1 - V5. Dependent on the configuration the level of VOUT or V5 can be measured by one of the μ P's analogue to digital converters (U0901-20) via resistive divider R0914, R0915. To stabilize the display brightness over a large temperature range the μ P measures the temperature via analogue to digital converter (U0901-18) using thermistor R0918 and resistor R0917. Dependent on the measured temperature the μ P adjusts the driver output voltage V5, and in turn the display brightness, via parallel interface.

3.10 Microphone Connector

Signals BUS+, PTT, HOOK, MIC HI, HANDSET AUDIO and FLT A+ available at the microphone connector J0903, are connected to the radio's controller section via connector J0901.

3.11 Electrostatic Transient Protection

Electrostatic transient protection is provided for the sensitive components in the control head by diodes VR0901 - VR0905, VR0931 - VR0935. The diodes limit any transient voltages to tolerable levels. The associated capacitors provide Radio Frequency Interference (RFI) protection.

Chapter 2.2

PCB/Schematic Diagram and Parts List

Table of Contents

Description	Page
Display/Keypad Radio Control Head (K6) - Diagrams and Parts Lists	
PCB Layout Top Side	1
PCB Layout Bottom Side	1
Schematic Diagram 1 of 2	2
Schematic Diagram 2 of 2	3
Parts List	4

Chapter 3

UHF/VHF Radio - Level 3 Information

Table of Contents

Chapter

- 3.1 Introduction/Theory of Operation**
- 3.2 PCB/Schematic Diagrams and Parts Lists**

Table of Contents

Chapter 3.1

Introduction/Theory of Operation

Table of Contents

Paragraph		Page
1.0	Introduction	1
2.0	Open Controller	1
2.1	General	1
2.2	Voltage Regulators	1
2.3	Electronic On/Off	2
2.4	Emergency.....	2
2.5	Mechanical On/Off	3
2.6	Ignition	3
2.7	Hook RSS	3
2.8	Microprocessor Clock Synthesizer	4
2.9	Serial Peripheral Interface (SPI).....	4
2.10	SPEB Serial Interface	5
2.11	General Purpose Input/Output.....	6
2.12	Normal Microprocessor Operation.....	6
2.13	FLASH Electronically Erasable Programmable Memory (FLASH EEPROM) ..	8
2.14	Electrically Erasable Programmable Memory (EEPROM)	8
2.15	Static Random Access Memory (SRAM).....	9
Controller Audio and Signalling Circuits		
3.0	General	9
3.1	Audio Signalling Filter IC (ASFIC)	9
3.2	Audio Ground.....	9
4.0	Transmit Audio Circuits	10
4.1	Mic Input Path.....	10
4.2	External Mic Path.....	11
4.3	PTT Sensing and TX Audio Processing	11
4.4	TX Secure Audio (optional).....	11

Paragraph	Page
5.0 Transmit Signalling Circuits	12
5.1 Sub-audible Data (PL/DPL)	12
5.2 High Speed Data	13
5.3 Dual Tone Multiple Frequency (DTMF) Data.....	13
6.0 Receive Audio Circuits	14
6.1 Squelch Detect	14
6.2 Audio Processing and Digital Volume Control.....	15
6.3 Audio Amplification Speaker (+) Speaker (-)	15
6.4 Handset Audio	16
6.5 Filtered Audio	16
6.6 RX Secure Audio (optional)	16
7.0 Receive Signalling Circuits	17
7.1 Sub-audible Data (PL/DPL) and High Speed Data Decoder	17
7.2 Alert Tone Circuits	17
UHF (403-470MHz) SPECIFIC CIRCUIT DESCRIPTION	
8.0 Receiver Front-End	18
8.1 Front-End Band-Pass Filter & Pre-Amplifier	18
8.2 Mixer and Intermediate Frequency (IF) Section	19
8.3 IF IC (U5201).....	19
9.0 Transmitter Power Amplifier (PA) 5-25W	19
9.1 Power Controlled Stage.....	19
9.2 PA Stages.....	20
9.3 Directional Coupler	20
9.4 Antenna Switch.....	21
9.5 Harmonic Filter	21
9.6 Power Control.....	21
10.0 Frequency Synthesis	23
10.1 Reference Oscillator	23
10.2 Fractional-N Synthesizer (U5701)	23
10.3 Voltage Controlled Oscillator (VCO).....	24
10.4 Synthesizer Operation	24

Paragraph		Page
VHF (136-174MHz) SPECIFIC CIRCUIT DESCRIPTION		
11.0	Receiver Front-End	25
11.1	Front-End Band-Pass Filter and Pre-Amplifier.....	25
11.2	Mixer and Intermediate Frequency (IF) Section.....	26
11.3	IF IC (U5201)	26
12.0	Transmitter Power Amplifier (PA) 5-25W	26
12.1	Power Controlled Stage	27
12.2	PA Stages	27
12.3	Directional Coupler	27
12.4	Antenna Switch	28
12.5	Harmonic Filter.....	28
12.6	Power Control	28
13.0	Frequency Synthesis	30
13.1	Reference Oscillator	30
13.2	Fractional-N Synthesizer (U3701).....	30
13.3	Voltage Controlled Oscillator (VCO)	30
13.4	Synthesizer Operation	31

1.0 Introduction

This section provides a detailed theory of operation for the radio and its components. The main radio is a single board design, consisting of the transmitter, receiver, and controller circuits.

The main board is designed to accept one additional option board. This may provide functions such as secure voice/data or DTMF decoder. The control head is mounted directly on the front of the radio or connected via an extension cable in remote mount operation. The control head contains LED indicators, a microphone connector, buttons/keypad and a display. These provide the user with interface control over the various features of the radio.

In addition to the power cable and antenna cable, an accessory cable can be attached to a connector on the rear of the radio. The accessory cable provides the necessary connections for items such as external speaker, emergency switch, foot operated PTT, ignition sensing, etc.

2.0 Open Controller

2.1 General

The radio controller consists of 4 main subsections:

- Digital Control
- Audio Processing
- Power Control
- Voltage Regulation

The digital control section of the radio board is based upon an open architecture controller configuration. It consists of a microprocessor, support memory, support logic, signal MUX ICs, the On/Off circuit, and general purpose Input/Output circuitry.

The controller uses the Motorola 68HC11K1 microprocessor (U0101). In addition to the microprocessor, the controller has 3 external memory devices. The 3 memory devices consist of a 32kbyte SRAM (U0103), a 512kbyte FLASH EEPROM (U0102), and a 16kbyte EEPROM (U0104).

Note: From this point on the 68HC11K1 microprocessor will be referred to as μP or $\text{K1}\mu\text{P}$.
References to the control head will be to the Display/Keypad radio model (K6).

2.2 Voltage Regulators

Voltage regulation for the controller is provided by 3 separate devices; U0631 (LP2951CM) +5V, U0601 (LM2941T) +9.3V, and UNSW 5V (a combination of R0621 and VR0621). An additional regulator is located in the RF section.

Voltage regulation providing 5V for the digital circuitry is done by U0631. Input and output capacitors (C0631/C0632 and C0633-C0635) are used to reduce high frequency noise and provide proper operation during battery transients. This regulator provides a reset output (pin 5) that goes to 0 volts if the regulator output goes out of regulation. This is used to reset the controller to prevent improper operation. Diode D0631 prevents discharge of C0632 by negative spikes on the 9V3 voltage.

Regulator U0601 is used to generate the 9.3 volts required by some audio circuits, the RF circuitry and power control circuitry. Input and output capacitors (C0601-C0603 and C0604/C0605) are used to reduce high frequency noise. R0602/R0603 set the output voltage of the regulator. If the voltage at pin 1 is greater than 1.3 volts the regulator output decreases and if the voltage is less than 1.3 volts the regulator output increases. This regulator output is electronically enabled by a 0 volt signal on pin 2. Q0601 and associated circuitry (R0601/R0604/R0605) are used to disable the regulator when the radio is turned off.

UNSW 5V is only used in a few areas which draw low current and require 5 V while the radio is off.

UNSW 5V CL is used to buffer the internal RAM. C0622 allows the battery voltage to be disconnected for a couple of seconds without losing RAM parameters. Diode D0621 prevents radio circuitry from discharging this capacitor.

The voltage 9V3 SUPP is only used in the VHF radio (T1) to supply the drain current for the RF MOS FET in the PA. The voltage SW B+ is monitored by the μ P through the voltage divider R0641/R0642 and line BATTERY VOLTAGE. Diode VR0641 limits the divided voltage to 5.1V to protect the μ P.

Diode D5601 (UHF) / D3601 (VHF) / D2601 (MB) located on the PA section acts as protection against transients and wrong polarity of the supply voltage.

2.3 Electronic On/Off

The radio has circuitry which allows radio software and/or external triggers to turn the radio on or off without direct user action. For example, automatic turn on when ignition is sensed and off when ignition is off.

Q0611 is used to provide SW B+ to the various radio circuits. Q0611 contains a pnp and an npn transistor and acts as an electronic on/off switch. The switch is on when the collector of the npn transistor (Q0611-1) is low. When the radio is off the pnp transistor is cutoff and the voltage at pin 1 is at A+. This effectively prevents current flow through the pnp transistor from emitter (pin 3) to collector (pin 2).

When the radio is turned on the voltage at the Q0611 pin 4 is high (about 4.4V) and the npn transistor switches on (saturation) and pulls down the voltage at the base of the pnp transistor. With Transistor Q0611 now "enabled" current flows through the device from pin 3 to pin 2. This path has a very low impedance (less than 1 ohm) from emitter to collector. This effectively provides the same voltage level at SWB+ as at A+.

The electronic on/off circuitry can be enabled by the microprocessor (through ASFIC port GCB2, line B+ CONTROL), the emergency switch (line EMERGENCY CONTROL), the mechanical On/Off button on the control head (line ON OFF CONTROL), or the ignition sense circuitry (line IGNITION CONTROL). If any of the 4 paths cause a low at Q0611 pin 1, the electronic ON is engaged.

2.4 Emergency

The emergency switch (J0400-9), when engaged, grounds the base of Q0441 and pulls the line EMERGENCY CONTROL to low via D0441. EMER IGN SENSE is pulled high by R0441. When the emergency switch is released the base of Q0441 is pulled high by R0442. This causes the collector of transistor Q0441 to go low (0.2V), thereby setting the EMER IGN SENSE line to low.

While EMERGENCY CONTROL is low, SW B+ is on, the microprocessor starts execution, reads that the emergency input is active through the voltage level of EMER IGN SENSE, and sets the B+ CONTROL output of the ASFIC pin B4 to a logic high. This high will keep Q0611 switched on. This operation allows a momentary press of the emergency switch to power up the radio. When the microprocessor has finished processing the emergency press, it sets the B+ CONTROL line to a logic 0. This turns off Q0611 and the radio turns off. Notice that the microprocessor is alerted to the emergency condition via line EMER IGN SENSE. If the radio was already on when emergency was triggered then B+ CONTROL would already be high.

2.5 Mechanical On/Off

This refers to the typical on/off button, located on the control head, and which turns the radio on and off. If the radio is turned off and the on/off button is pressed, line ON OFF CONTROL goes high and switches the radio on as long as the button is pressed. The microprocessor is alerted through line ANALOG 3 which is pulled to low by Q0925 (Display/Keypad Control Head) while the on/off button is pressed. If the software detects a low state it asserts B+ CONTROL via ASFIC pin B4 high which keeps Q0611, and in turn the radio switched on.

If the on/off button is pressed and held while the radio is on, the software detects the line ANALOG 3 changing to low and switches the radio off by setting B+ CONTROL to low.

2.6 Ignition

Ignition sense is used to prevent the radio from draining the vehicle's battery because the engine is not running.

When the IGNITION input (J0400-10) goes above 6 volts Q0611 is turned on via line IGNITION CONTROL. Q0611 turns on SW B+ and the microprocessor starts execution. A high IGNITION input reduces the voltage of line EMER IGN SENSE by turning on Q0450. The software reads the line EMER IGN SENSE, determines from the level (Emergency has a different level) that the IGNITION input is active and sets the B+ CONTROL output of the ASFIC pin B4 to high to latch on SW B+.

When the IGNITION input goes below 6 volts, Q0450 switches off and R0449, R0450 pull line EMER IGN SENSE high. The software is alerted by line EMER IGN SENSE to switch off the radio by setting B+ CONTROL to low. The next time the IGNITION input goes above 6 volts the above process will be repeated.

2.7 Hook RSS

The HOOK RSS input is used to inform the μ P when the Microphone's hang-up switch is engaged. Dependent on the radio model the μ P may take actions like turning the audio PA on or off. The signal is routed from J0101-3 and J0400-14 through transistor Q0101 to the K1 μ P U0101-23. The voltage range of HOOK RSS in normal operating mode is 0-5V.

To start SBEP communication this voltage must be above 6V. This condition generates a μ P interrupt via VR0102, Q0105, Q0104, Q0106 and enables the BUS+ line for communication via Q0122, Q0121.

2.8 Microprocessor Clock Synthesizer

The clock source for the microprocessor system is generated by the ASFIC (U0201). Upon power-up the synthesizer U5701 (UHF) / U3701 (VHF) / U2701 (MB) generates a 2.1 MHz waveform that is routed from the RF section (via C0202) to the ASFIC (on U0201-E1) For the main board controller the ASFIC uses 2.1MHz as a reference input clock signal for its internal synthesizer. The ASFIC, in addition to audio circuitry, has a programmable synthesizer which can generate a synthesized signal ranging from 1200Hz to 32.769MHz in 1200 Hz steps.

When power is first applied, the ASFIC will generate its default 3.6864 MHz CMOS square wave μ P CLK (on U0201-D1) and this is routed to the microprocessor (U0101-73). After the microprocessor starts operation, it reprograms the ASFIC clock synthesizer to a higher μ P CLK frequency (usually 7.9488 MHz) and continues operation.

The ASFIC may be reprogrammed to change the clock synthesizer frequencies at various times depending on the software features that are executing. In addition, the clock frequency of the synthesizer is changed in small amounts if there is a possibility of harmonics of this clock source interfering with the desired radio receive frequency.

The ASFIC synthesizer loop uses C0228, C0229 and R0222 to set the switching time and jitter of the clock output. If the synthesizer cannot generate the required clock frequency it will switch back to its default 3.6864MHz output.

Because the ASFIC synthesizer and the μ P system will not operate without the 2.1MHz reference clock, it (and the voltage regulators) should be checked first when debugging the system.

2.9 Serial Peripheral Interface (SPI)

The μ P communicates to many of the ICs through its SPI port. This port consists of SPI TRANSMIT DATA (MOSI) (U0101-1), SPI RECEIVE DATA (MISO) (U0101-80), SPI CLK (U0101-2) and chip select lines going to the various ICs, connected on the SPI PORT (BUS). This BUS is a synchronous bus, in that the timing clock signal CLK is sent while SPI data (SPI TRANSMIT DATA or SPI RECEIVE DATA) is sent. Therefore, whenever there is activity on either SPI TRANSMIT DATA or SPI RECEIVE DATA there should be a uniform signal on CLK. The SPI TRANSMIT DATA is used to send serial from a μ P to a device, and SPI RECEIVE DATA is used to send data from a device to a μ P. The only device from which data can be received via SPI RECEIVE DATA is the EEPROM (U0104 or U0107) and a control head with graphical display (Display/Keypad Radio Model K6).

On the controller there are three ICs on the SPI BUS, ASFIC (U0201-F2), EEPROM (U0104-1 or U0107-1) and D/A (U0731-6). In the RF sections there is one IC on the SPI BUS which is the FRAC-N Synthesizer. The SPI TRANSMIT DATA and CLK lines going to the RF section are filtered by L0131/L0132 to minimize noise. The chip select lines for the IC's are decoded by the address decoder U0105.

The SPI BUS is also used for the control head. U0106-2,3 buffer the SPI TRANSMIT DATA and CLK lines to the control head. U0106-1 switch off the CLK signal for the LCD display if it is not selected via LCD CE and Q0141.

When the μ P needs to program any of these IC's it brings the chip select line for that IC to a logic 0 and then sends the proper data and clock signals. The amount of data sent to the various IC's are different, for example the FRAC-N can receive up to 21 bytes (168 bits) while the DAC can receive up to 3 bytes (24 bits). After the data has been sent the chip select line is returned to a logic 1.

When the control head with graphical display wants to communicate to the μ P it brings request line ANALOG 2 (J0101-11) to a logic "0". The μ P reads this line via one of the analogue to digital converters (U0101-48) and then starts communication by activating the control head select line (LED CHT CE) via U0105-9 and J0101-12, sending the clock signal via U0106-3 and J0101-5 and sending data via U0106-2 and J0101-6 or receiving data via J0101-10 and gate U0171. During data transfer gate U0171 is switched on by line LED CHT CE via transistor Q0171 and gate U0172-1. Gate U0172-1 is enabled by the μ P via ASFIC output GCB4 (U0201-A2).

The Option board interfaces are different in that the μ P can also read data back from devices connected. The timing and operation of this interface is specific to the option connected, but generally follows the pattern:

1. an option board device generates an interrupt via J0103-8, Q0124, Q0125 and μ P pin 61 (IRQ). The μ P determines the interrupt source by reading a high at the collector of Q0124 via μ P pin 7 and R0129.
2. the main board asserts a chip select for that option board device via U0105-10, J0102-5,
3. the main board μ P generates the CLK (J0102-6),
4. the main board μ P writes serial data via J0102-4 and reads serial data via J0102-2 and,
5. when data transfer is complete the main board terminates the chip select and CLK activity.

2.10 SPEB Serial Interface

The SBEP serial interface allows the radio to communicate with the Dealer Programming Software (DPS) via the Radio Interface Box (RIB). This interface connects to the Microphone connector (J0903/J0803) via Control Head connector (J0101-15) or to the accessory connector J0400-6 and comprises BUS+ (J0101-15). The line is bi-directional, meaning that either the radio or the DPS can drive the line.

When the RIB (Radio Interface Box) is connected to the radio, a voltage on the HOOK RSS line above 6 volts switches on Q0105. The low state at collector of Q0105 switches Q0104 off and in turn, Q0106 on. A high to low transition at the collector of Q0106 generates an interrupt via μ P pin 61. The μ P determines the interrupt source by reading a high at the collector of Q0104 via μ P pin 6 and R0125. The switched on Q0105 also switches off Q0122 enabling the μ P to read BUS+ via pin 78 and to write BUS+ via pin 79 and transistors Q0123, Q0121. While the radio is sending serial data at pin 79 via Q0123 and Q0121 it receives an "echo" of the same data at pin 78.

When the voltage on the HOOK RSS line is below 6 volts (RIB is not connected), the high collector of Q0105 turns on Q0122. The low collector of Q0122 prevents the μ P from writing data to BUS+ via Q0123. In this mode line BUS+ is used for signal SCI RX of the Serial Communication Interface (SCI). The μ P reads the SCI via signal SCI RX (pin 78) and writes via signal SCI TX (pin 79). Both signals are available on the accessory connector J0400 (SCI DATA OUT, SCI DATA IN).

2.11 General Purpose Input/Output

The Controller provides one general purpose line (GP I/O) available on the accessory connector J0400-12 to interface to external options. The software and the hardware configuration of the radio model defines the function of the port. The port uses an output transistor (Q0432) controlled by μP via ASFIC port GCB3 (pin B3).

An external alarm output, available on J0400 pin 4 is generated by the μP via ASFIC port GCB1 (pin A3) and transistor Q0411. Input EXTERNAL PTT on J0400 pin 3 is read by the μP via line REAR PTT and μP pin 8.

Pin 13 of the accessory connector J0400 provides a voltage at battery level while the radio is switched on. The output is capable to drive a dc current up to 20mA. When the radio is switched on, the voltage 9V3 turns on transistor Q0482. Transistor Q0482 switches on Q0481 and enables a current flow from emitter to collector of Q0481. This path has a very low impedance and effectively provides the same voltage level at SW FLT A+ as at FLT A+. If the radio is switched off the voltage 9V3 is at ground level which switches off Q0482 and in turn cuts off the current from emitter to collector of Q0481.

2.12 Normal Microprocessor Operation

For this radio, the μP is configured to operate in one of two modes, expanded and bootstrap. In expanded mode the μP uses external memory devices to operate, whereas in bootstrap operation the μP uses only its internal memory. In normal operation of the radio the μP is operating in expanded mode as described below.

In expanded mode on this radio, the μP (U0101) has access to three external memory devices; U0102 (FLASH EEPROM), U0103 (SRAM), U0104 or U0107 (optional EEPROM). Also, within the μP there are 768 bytes of internal RAM and 640 bytes of internal EEPROM, as well as logic to select external memory devices.

The (optional) external EEPROM (U0104 or U0107) as well as the μP 's own internal EEPROM space contain the information in the radio which is customer specific, referred to as the codeplug. This information consists of items such as: 1) what band the radio operates in, 2) what frequencies are assigned to what channel, and 3) tuning information. In general tuning information and other more frequently accessed items are stored in the internal EEPROM (space within the 68HC11K1), while the remaining data is stored in the external EEPROM. (See the particular device subsection for more details.)

The external SRAM (U0103) as well as the μP 's own internal RAM space are used for temporary calculations required by the software during execution. All of the data stored in both of these locations is lost when the radio powers off (See the particular device subsection for more details).

The FLASH EEPROM contains the actual Radio Operating Software. This software is common to all open architecture radios within a given model type. For example Securenet radios may have a different version of software in the FLASH EEPROM than a non-secure radio (See the particular device subsection for more details).

The K1 μP provides an address bus of 16 address lines (A0-A15), and a data bus of 8 data lines (D0-D7). There are also three control lines; CSPROG (U0101-29) to chip select U0102-30 (FLASH EEPROM), CSGP2 (U0101-28) to chip select U0103-20 (SRAM) and PG7_R_W to select whether to read or to write. All other chips (ASFIC/PENDULLUM/DAC/FRCN/LCD/LED/optional EEPROM/OPTION BOARD) are selected by 3 lines of the μP using address decoder U0105. When the μP is functioning normally, the address and data lines should be toggling at CMOS logic levels.

Specifically, the logic high levels should be between 4.8 and 5.0 V, and the logic low levels should be between 0 and 0.2 V. No other intermediate levels should be observed, and the rise and fall times should be <30 ns.

The low-order address lines (A0-A7) and the data lines (D0-D7) should be toggling at a high rate, i.e., you should set your oscilloscope sweep to 1 us/div. or faster to observe individual pulses. High speed CMOS transitions should also be observed on the μ P control lines.

On the μ P the lines XIRQ (U0101-30), MODA LIR (U0101-77), MODB VSTPY (U0101-76) and RESET (U0101-75) should be high at all times during normal operation. Whenever a data or address line becomes open or shorted to an adjacent line, a common symptom is that the RESET line goes low periodically, with the period being in the order of 20 msec. In the case of shorted lines you may also detect the line periodically at an intermediate level, i.e. around 2.5 V when 2 shorted lines attempt to drive to opposite rails.

The MODA LIR (U0101-77) and MODB VSTPY (U0101-76) inputs to the μ P must be at a logic 1 for it to start executing correctly. After the μ P starts execution it will periodically pulse these lines to determine the desired operating mode. While the Central Processing Unit (CPU) is running, MODA LIR is an open-drain CMOS output which goes low whenever the μ P begins a new instruction (an instruction typically requires 2-4 external bus cycles, or memory fetches).

However, since it is an open-drain output, the waveform rise assumes an exponential shape similar to an RC circuit.

There are eight analogue to digital converter ports (A/D) on U0101. They are labelled within the device block as PE0-PE7. These lines sense the voltage level ranging from 0 to 5 V of the input line and convert that level to a number ranging from 0 to 255 which can be read by the software to take appropriate action.

For example, U0101-46 is the battery voltage detect line. R0641 and R0642 form a resistor divider on SWB+. With 30K and 10K and a voltage range of 11 V to 17 V, that A/D port would see 2.74 V to 4.24 V which would then be converted to ~140 to 217 respectively.

U0101-51 is the high reference voltage for the A/D ports on the μ P. Resistor R0106 and capacitor C0106 filter the +5 V reference. If this voltage is lower than +5 V the A/D readings will be incorrect. Likewise U0101-50 is the low reference for the A/D ports. This line is normally tied to ground. If this line is not connected to ground, the A/D readings will be incorrect.

Capacitors C0104, C0105, C0113, C0114 serve to filter out any AC noise which may ride on +5V at U0101.

Input IRQ (U0101-61) generates an interrupt, if either HOOK RSS (J0101-3) is higher than 6V (SBEP communication) and turns Q0106 on via Q0105, Q0104, or a low at the option interrupt pin (J0103-8) turns Q0124 off and Q0125 on. The μ P determines the interrupt source by reading the collector of Q0104 via U0101-6 and the collector Q0124 via U0101-7.

2.13 FLASH Electronically Erasable Programmable Memory (FLASH EEPROM)

The 512 KByte FLASH EEPROM (U0102) contains the radio operating software. This software is common to all open architecture radios within a given model type. This is, as opposed to the codeplug information stored in EEPROM (U0104) which could be different from one user to another in the same company.

In normal operating mode, this memory is only read, not written to. The memory access signals (CE, OE and WE) are generated by the μ P.

To upgrade/reprogram the FLASH software, the μ P must be set in bootstrap operating mode, and the FLASH device pin (U0102-9) V_{pp} must be between 11.4 and 12.6 V. This voltage switches Q0102 on and in turn Q0103 off. The low state at collector of Q0102 pulls MODA LIR (U0101-77) and MODB VSTBY (U0101-76) via diode D0101 to low which enables the bootstrap operating mode after power up. The high state at collector of Q0103 enables the μ P to control the FLASH EN OE (U0102-32) input via U0106-4. Chip select (U102-30) and read or write operation (U102-7) are controlled by μ P pins 29 and 33. In normal operating mode V_{pp} is below 5V which switches Q0102 off and Q0103 on.

The FLASH device may be reprogrammed 1,000 times without issue. It is not recommended to reprogram the FLASH device at a temperature below 0°C.

Capacitor C0131 serves to filter out any AC noise which may ride on +5V at U0101, and C0132 filters out any AC noise on V_{pp} .

2.14 Electrically Erasable Programmable Memory (EEPROM)

The optional EEPROM (U0104 or U0107) contains additional radio operating parameters such as operating frequency and signalling features, commonly known as the codeplug. It is also used to store radio operating state parameters such as current mode and volume. U0104 can have up to 8kbyte and U0107 up to 16 kbyte. This memory can be written to in excess of 100,000 times and will retain the data when power is removed from the radio. The memory access signals (SI, SO and SCK) are generated by the μ P and chip select (CS) is generated by address decoder U0105-4.

Additional EEPROM is contained in the μ P (U0101). This EEPROM is used to store radio tuning and alignment data. Like the external EEPROM this memory can be programmed multiple times and will retain the data when power is removed from the radio.

Note: The external EEPROM plus the 640 bytes of internal EEPROM in the 68HC11K1 comprise the complete codeplug.

2.15 Static Random Access Memory (SRAM)

The SRAM (U0103) contains temporary radio calculations or parameters that can change very frequently, and which are generated and stored by the software during its normal operation. The information is lost when the radio is turned off. The device allows an unlimited number of write cycles. SRAM accesses are indicated by the CS signal U103-20 (which comes from U101-CSGP2) going low. U0103 is commonly referred to as the external RAM as opposed to the internal RAM which is the 768 bytes of RAM which is part of the 68HC11K1. Both RAM spaces serve the purpose. However, the internal RAM is used for the calculated values which are accessed most often. Capacitor C0133 serves to filter out any ac noise which may ride on +5V at U0103.

CONTROLLER BOARD AUDIO AND SIGNALLING CIRCUITS

3.0 General

3.1 Audio Signalling Filter IC (ASFIC)

The ASFIC (U0201) used in the controller has 4 functions;

- RX/TX audio shaping, i.e. filtering, amplification, attenuation
- RX/TX signalling, PL/DPL/HST/MDC/MPT
- Squelch detection
- Microprocessor clock signal generation (see Microprocessor Clock Synthesizer Description Block).

The ASFIC is programmable through the SPI BUS (U0201-E3/F1/F2), normally receiving 21 bytes. This programming sets up various paths within the ASFIC to route audio and/or signalling signals through the appropriate filtering, gain and attenuator blocks. The ASFIC also has 6 General Control Bits GCB0-5 which are CMOS level outputs and used for AUDIO PA ENABLE (GCB0) to switch the audio PA on and off, EXTERNAL ALARM (GCB1) and B+ CONTROL (GCB2) to switch the voltage regulators (and the radio) on and off. GCB3 controls output GPI/O (accessory connector J0400-12), HIGH LOW BAND (GCB4) can be used to switch between band splits and GCB5 is available on the option board connector J0102-3. Output GCB4 controls gate U0171 via U0172-1 which enables the μ P to receive data from the control head. The supply voltage for the ASFIC has additional filtering provided by Q0200, D0200, R0200, L0200 and C0200. Diode D0200 increases the voltage at the base of Q0200 about 0.6 volts above the 5 volt supply voltage to compensate the base - emitter voltage drop of Q0200.

3.2 Audio Ground

VAG is the dc bias used as an audio ground for the op-amps that are external to the Audio Signalling Filter IC (ASFIC). U0251-1 form this bias by dividing 9.3V with resistors R0251, R0252 and buffering the 4.65V result with a voltage follower. VAG emerges at pin 1 of U0251-1. C0253 is a bypass capacitor for VAG. The ASFIC generates its own 2.5V bias for its internal circuitry. C0221 is the bypass for the ASFIC's audio ground dc bias. Note that while there are ASFIC VAG, and BOARD VAG (U0201-1) each of these are separate; they do not connect together.

4.0 Transmit Audio Circuits

Refer to Figure 3-1 for reference for the following sections.

4.1 Mic Input Path

The radio supports two distinct microphone paths known as internal (from Control Head) and external mic (from accessory connector J0400-2) and an auxiliary path (FLAT TX AUDIO). The microphones used for the radio require a DC biasing voltage provided by a resistive network.

These two microphone audio inputs are connected together through R0413; resistors R0414 and R0415 are not placed. Following the internal mic path; the microphone is plugged into the radio control head and is connected to the controller board via J101-16.

From here the signal is routed to R0206. R0204 and R0205 provide the 9.3VDC bias and R0206 provides input protection for the CMOS amplifier input. R0205 and C0209 provide a 1kΩ AC path to ground that sets the input impedance for the microphone and determines the gain based on the emitter resistor in the microphone's amplifier circuit.

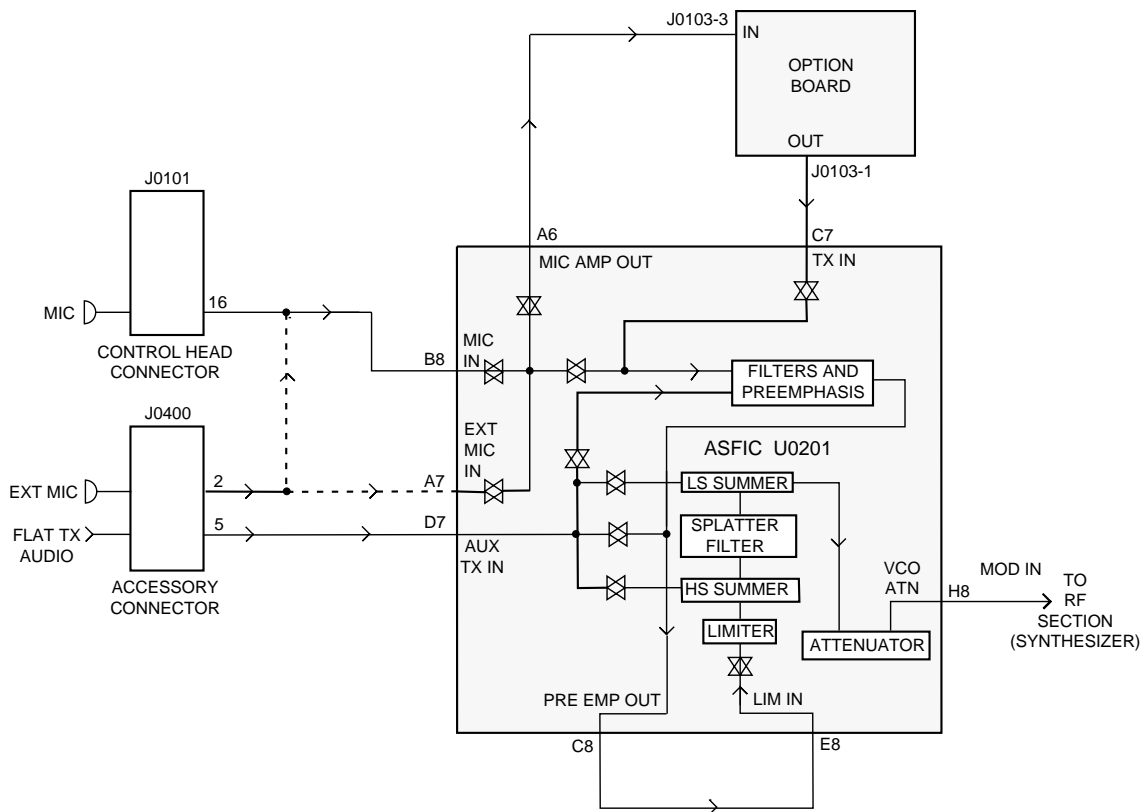

GEPD5426-1

Figure 3-1 Transmit Audio Paths

Filter capacitor C0210 provides low-pass filtering to eliminate frequency components above 3 kHz, and C0211 serves as a DC blocking capacitor. The audio signal at U0201-B8 should be approximately 80mV for 1.5kHz or 3kHz of deviation with 12.5kHz or 25 kHz channel spacing. The FLAT TX AUDIO signal from accessory connector J0400-5 is buffered by op-amp U0202-1 and fed to the ASFIC U0201-D7 through C0205.

4.2 External Mic Path

The external microphone signal enters the radio on accessory connector J0400 pin 2 and connects to the standard microphone input through R0413. Components R0414 - R0416, C0413, C0414, C0417 are not used.

4.3 PTT Sensing and TX Audio Processing

Mic PTT coming from the Control Head via connector J101-4 is sensed by the μ P U0101 pin 22. An external PTT can be generated by grounding pin 3 on the accessory connector. When microphone PTT or external PTT is sensed, the μ P will always configure the ASFIC for the "internal" mic audio path.

Inside the ASFIC, the MIC audio is filtered to eliminate frequency components outside the 300-3000Hz voice band, pre-emphasized if pre-emphasis is enabled. The capacitor between ASFIC pre-emphasis out U0201-C8 and ASFIC limiter in U0201-E8 AC couples the signal between ASFIC blocks and prevents the DC bias at the ASFIC output U0201-H8 from shifting when the ASFIC transmit circuits are powered up. The signal is then limited to prevent the transmitter from over deviating. The limited MIC audio is then routed through a summer which, is used to add in signalling data, and then to a splatter filter to eliminate high frequency spectral components that could be generated by the limiter. The audio is then routed to two attenuators, which are tuned in the factory or the field to set the proper amount of FM deviation. The TX audio emerges from the ASFIC at U0201-H8 MOD IN, at which point it is routed to the RF section.

4.4 TX Secure Audio (optional)

The audio follows the normal transmit audio processing until it emerges from the ASFIC MIC AMP OUT pin (U0201-A6), which is fed to the Secure board residing at option connector J0103-3. The Secure board contains circuitry to amplify, encrypt, and filter the audio. The encrypted signal is then fed back from J0103-1 to the ASFIC TX IN input (U0201-C7). The signal level at this pin should be about 80mVrms. The signal is then routed through the TX path in the ASFIC and emerges at VCO ATN pin H8.

5.0 Transmit Signalling Circuits

Refer to Figure 3-2 for reference for the following sections. From a hardware point of view, there are three types of signalling:

1. Sub-audible data (PL/DPL/Connect Tone) that gets summed with transmit voice or signalling,
2. DTMF data for telephone communication in trunked and conventional systems, and
3. Audible signalling including Select 5, MPT-1327, MDC, High speed Trunking.

NOTE: All three types are supported by the hardware while the radio software determines which signalling type is available.

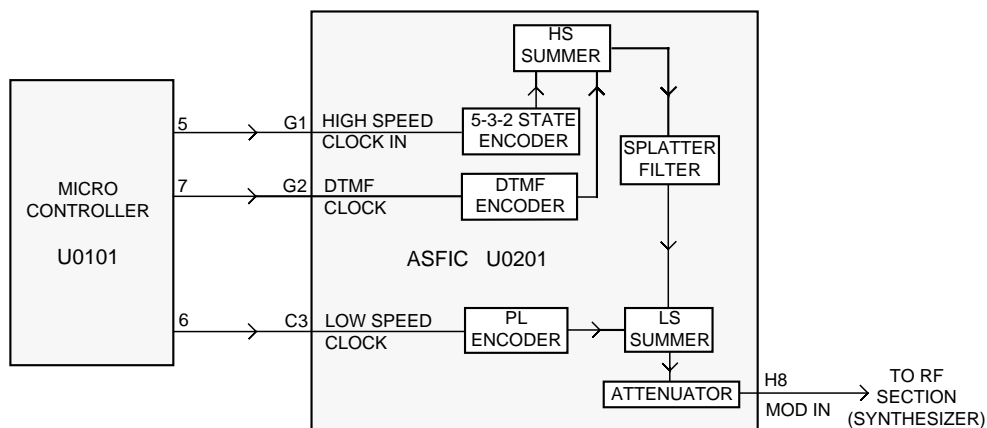

GEPD5433

Figure 3-2 Transmit Signalling Paths

5.1 Sub-audible Data (PL/DPL)

Sub-audible data implies signalling whose bandwidth is below 300Hz. PL and DPL waveforms are used for conventional operation and connect tones for trunked voice channel operation. The trunking connect tone is simply a PL tone at a higher deviation level than PL in a conventional system. Although it is referred to as "sub-audible data," the actual frequency spectrum of these waveforms may be as high as 250 Hz, which is audible to the human ear. However, the radio receiver filters out any audio below 300Hz, so these tones are never heard in the actual system.

Only one type of sub-audible data can be generated by U0201 (ASFIC) at any one time. The process is as follows, using the SPI BUS, the μ P programs the ASFIC to set up the proper low-speed data deviation and select the PL or DPL filters. The μ P then generates a square wave which strobes the ASFIC PL / DPL encode input PL CLK U0201-C3 at twelve times the desired data rate. For example, for a PL frequency of 103Hz, the frequency of the square wave would be 1236Hz.

This drives a tone generator inside U0201 which generates a staircase approximation to a PL sine wave or DPL data pattern. This internal waveform is then low-pass filtered and summed with voice or data. The resulting summed waveform then appears on U0201-H8 (MOD IN), where it is sent to the RF board as previously described for transmit audio. A trunking connect tone would be generated in the same manner as a PL tone.

5.2 High Speed Data

High speed data refers to the 3600 baud data waveforms, known as Inbound Signalling Words (ISWs) used in a trunking system for high speed communication between the central controller and the radio. To generate an ISW, the μ P first programs the ASFIC (U0201) to the proper filter and gain settings. It then begins strobing U0201-G1 (TRK CLK IN) with a pulse when the data is supposed to change states. U0201's 5-3-2 State Encoder (which is in a 2-state mode) is then fed to the post-limiter summer block and then the splatter filter.

From that point it is routed through the modulation attenuators and then out of the ASFIC to the RF board. MPT 1327 and MDC are generated in much the same way as Trunking ISW. However, in some cases these signals may also pass through a data pre-emphasis block in the ASFIC. Also these signalling schemes are based on sending a combination of 1200 Hz and 1800 Hz tones only. Microphone audio is muted during High Speed Data signalling.

5.3 Dual Tone Multiple Frequency (DTMF) Data

DTMF data is a dual tone waveform used during phone interconnect operation. It is the same type of tones which are heard when using a "Touch Tone" telephone.

There are seven frequencies, with four in the low group (697, 770, 852, 941Hz) and three in the high group (1209, 1336, 1477Hz).

The high-group tone is generated by the μ P (U0101-5) strobing U0201-G1 at six times the tone frequency for tones less than 1440Hz or twice the frequency for tones greater than 1440Hz. The low group tone is generated by the μ P (U0101-7) strobing U0201-G2 (DTMF CLCK) at six times the tone frequency. Inside U0201 the low-group and high-group tones are summed (with the amplitude of the high group tone being approximately 2 dB greater than that of the low group tone) and then pre-emphasized before being routed to the summer and splatter filter. The DTMF waveform then follows the same path as was described for high-speed data.

6.0 Receive Audio Circuits

Refer to Figure 3-3 for reference for the following sections.

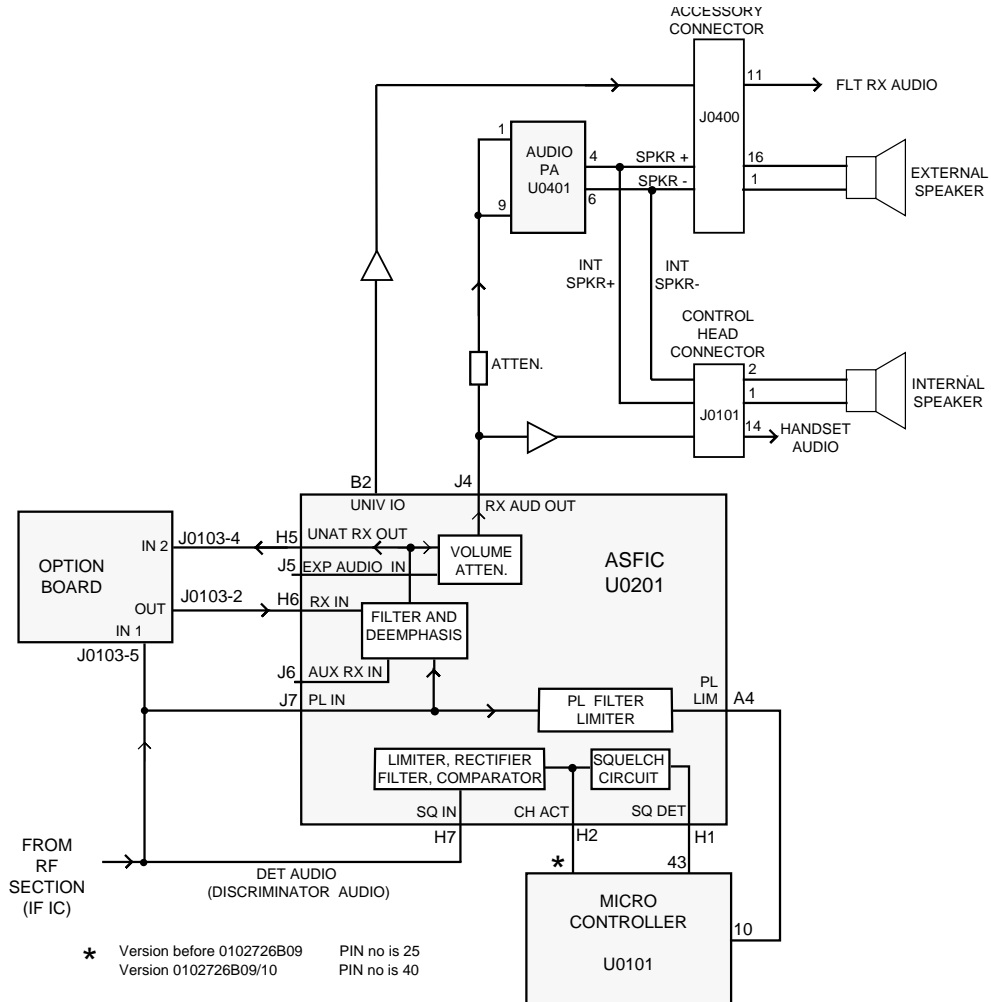

GEPD5428-2

Figure 3-3 Receive Audio Paths.

6.1 Squelch Detect

The radio's RF circuits are constantly producing an output at the discriminator U5201-28 (UHF) / U5201-28 (VHF) / U2201-28 (MB). This signal (DET AUDIO) is routed to the ASFIC's squelch detect circuitry input SQ IN (U0201-H7). All of the squelch detect circuitry is contained within the ASFIC. Therefore from a user's point of view, DET AUDIO enters the ASFIC, and the ASFIC produces two CMOS logic outputs based on the result. They are CH ACT (U0201-H2) and SQ DET (U0201-H1).

The squelch signal entering the ASFIC is amplified, filtered, attenuated, and rectified. It is then sent to a comparator to produce an active high signal on CH ACT. A squelch tail circuit is used to produce SQ DET (U0201-H1) from CH ACT. The state of CH ACT and SQ DET is high (logic 1) when carrier is detected, otherwise low (logic 0).

CH ACT is routed to the μ P pin 40 while SQ DET adds up with LOCK DET, weighted by resistors R0113, R0114, and is routed to one of the μ P's ADC inputs U0101-43. From the voltage weighted by the resistors the μ P determines whether SQ DET, LOCK DET or both are active.

SQ DET is used to determine all audio mute/unmute decisions except for Conventional Scan. In this case CH ACT is a pre-indicator as it occurs slightly faster than SQ DET.

6.2 Audio Processing and Digital Volume Control

The receiver audio signal enters the controller section from the IF IC U5201-28 (UHF) / U5201-28 (VHF) / U2201-28 (MB) on DET AUDIO and passes through RC filter, R0203 and C0208 which filters out IF noise. The signal is AC coupled by C0207 and enters the ASFIC via the PL IN pin U0201-J7.

Inside the ASFIC, the signal goes through 2 paths in parallel, the audio path and the PL/DPL path.

The audio path has a programmable amplifier, whose setting is based on the channel bandwidth being received, then a LPF filter to remove any frequency components above 3000Hz and then an HPF to strip off any sub-audible data below 300Hz. Next, the recovered audio passes through a de-emphasis filter if it is enabled (to compensate for Pre-emphasis which is used to reduce the effects of FM noise). The IC then passes the audio through the 8-bit programmable attenuator whose level is set depending on the value of the volume control. Finally the filtered audio signal passes through an output buffer within the ASFIC. The audio signal exits the ASFIC at RX AUDIO (U0201-J4).

The μ P programs the attenuator, using the SPI BUS, based on the volume setting. The minimum / maximum settings of the attenuator are set by codeplug parameters.

Since sub-audible signalling is summed with voice information on transmit, it must be separated from the voice information before processing. Any sub-audible signalling enters the ASFIC from the IF IC at PL IN U0201-J7. Once inside it goes through the PL/DPL path.

The signal first passes through one of 2 low pass filters, either PL low pass filter or DPL/LST low pass filter. Either signal is then filtered and goes through a limiter and exits the ASFIC at PL LIM (U0201-A4). At this point the signal will appear as a square wave version of the sub-audible signal which the radio received. The microprocessor (U0101-10) will decode the signal directly to determine if it is the tone/code which is currently active on that mode.

6.3 Audio Amplification Speaker (+) Speaker (-)

The output of the ASFIC's digital volume pot, U0201-J4 is routed through a voltage divider formed by R0401 and R0402 to set the correct input level to the audio PA (U0401). This is necessary because the gain of the audio PA is 46 dB, and the ASFIC output is capable of overdriving the PA unless the maximum volume is limited.

The audio then passes through C0401 which provides AC coupling and low frequency roll-off. C0402 provides high frequency roll-off as the audio signal is routed to pins 1 and 9 of the audio power amplifier U0401.

The audio power amplifier has one inverted and one non-inverted output that produces the differential audio output SPK+ / SPK- (U0401-4/6). The inputs for each of these amplifiers are pins 1 and 9 respectively; these inputs are both tied to the received audio. The audio PA's DC biases are not activated until the audio PA is enabled at pin 8.

The audio PA is enabled via AUDIO PA ENABLE signal from the ASFIC (U0201-B5). When the base of Q0401 is low, the transistor is off and U0401-8 is high, using pull up resistor R0406, and the Audio PA is ON. The voltage at U0401-8 must be above 8.5VDC to properly enable the device. If the voltage is between 3.3 and 6.4V, the device will be active but has its input (U0401-1/9) off. This is a mute condition which is not employed in this radio design. R0404 ensures that the base of Q0401 is high on power up. Otherwise there may be an audio pop due to R0406 pulling U0401-8 high before the software can switch on Q0401.

The SPK+ and SPK- outputs of the audio PA have a DC bias which varies proportionately with FLT A+ (U0401-7). FLT A+ of 11V yields a DC offset of 5V, and FLT A+ of 17V yields a DC offset of 8.5V. If either of these lines is shorted to ground, it is possible that the audio PA will be damaged. SPK+ and SPK- are routed to the accessory connector (J400-16 and 1) and to the control head (connector J0101-1 and 2).

6.4 Handset Audio

Certain hand held accessories have a speaker within them which require a different voltage level than that provided by U0401. For those devices HANDSET AUDIO is available at J0101-14.

The received audio from the output of the ASFIC's digital volume attenuator is also routed to U0202-4 pin 9 where it is amplified 15 dB; this is set by the 10k/68k combination of R0233 and R0232. This signal is routed from the output of the op amp U202-4 pin 8 to J0101-14. The control head sends this signal directly out to the microphone jack. The maximum value of this output is 6.6Vp-p.

6.5 Filtered Audio

The ASFIC has an audio whose output at U0201-B2 has been filtered and de-emphasized, but has not gone through the digital volume attenuator. From ASFIC U0201-B2 the signal is AC coupled to U0202-2 by capacitor C0230. R0224 and R0225 determine the gain of op-amp U0202-2. The output of U0202-2 is the routed to J0400-11. Note that any volume adjustment of the signal on this path must be done by the accessory.

6.6 RX Secure Audio (optional)

Discriminator audio, which is now encrypted audio, enters the Secure board at connector J0103-5. On the Secure board, the encrypted signal is converted back to normal audio format, and then fed back through (J0103-2) to RX IN of the ASFIC (U0201-H6). From then on it follows a path identical to conventional receive audio, where it is filtered (0.3 - 3kHz) and de-emphasized. The signal UNAT RX OUT from the ASFIC (U0201-H5), also routed to option connector J0103-4, is not used for the Secure board but for other option boards.

7.0 Receive Signalling Circuits

Refer to Figure 3-4 for reference for the following sections.

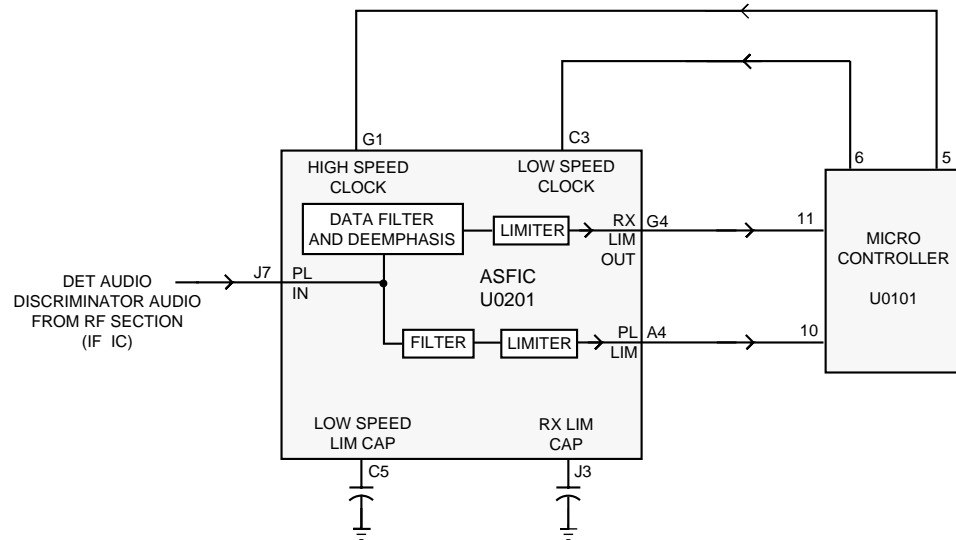

GEPD5431

Figure 3-4 Receive Signalling Path.

7.1 Sub-audible Data (PL/DPL) and High Speed Data Decoder

The ASFIC (U0201) is used to filter and limit all received data. The data enters the ASFIC at U0201-J7. Inside U0201 the data is filtered according to data type (HS or LS), then it is limited to a 0-5V digital level. The MDC and trunking high speed data appear at U0201-G4, where it connects to the μ P U0101-11

The low speed limited data output (PL, DPL, and trunking LS) appears at U0201-A4, where it connects to the μ P U0101-10. While receiving low speed data, the μ P may output a sampling waveform, depending on the sampling technique, to U0201-C3 between 1 and 2 kHz.

The low speed data is read by the μ P at twice the frequency of the sampling waveform; a latch configuration in the ASFIC stores one bit every clock cycle. The external capacitors C0226, C0225, and C0223 set the low frequency pole for a zero crossings detector in the limiters for PL and HS data. The hysteresis of these limiters is programmed based on the type of received data. Note that during HS data the μ P may generate a sampling waveform seen at U0201-G1.

7.2 Alert Tone Circuits

When the software determines that it needs to give the operator an audible feedback (for a good key press, or for a bad key press), or radio status (trunked system busy, phone call, circuit failures), it sends an alert tone to the speaker.

It does so by sending SPI BUS data to U0201 which sets up the audio path to the speaker for alert tones. The alert tone itself can be generated in one of two ways: internally by the ASFIC, or externally using the μ P and the ASFIC.

The allowable internal alert tones are 304, 608, 911, and 1823Hz. In this case a code contained within the SPI BUS load to the ASFIC sets up the path and determines the tone frequency, and at what volume level to generate the tone. (It does not have to be related to the voice volume setting).

For external alert tones, the μ P can generate any tone within the 100-3000Hz audio band. This is accomplished by the μ P generating a square wave which enters the ASFIC at U0201-C3.

Inside the ASFIC, this signal is routed to the alert tone generator. The output of the generator is summed into the audio chain just after the RX audio de-emphasis block. Inside U0201 the tone is amplified and filtered, then passed through the 8-bit digital volume attenuator, which is typically loaded with a special value for alert tone audio. The tone exits at U0201-J4 and is routed to the audio PA like receive audio.

UHF (403-470MHz) SPECIFIC CIRCUIT DESCRIPTION

8.0 Receiver Front-End

The receiver is able to cover the UHF range from 403 to 470 MHz. It consists of four major blocks: front-end, mixer, first IF section and IF IC. Antenna signal pre-selection is performed by two varactor tuned bandpass filters. A double balanced shottky diode mixer converts the signal to the first IF at 45.1 MHz.

Two crystal filters in the first IF section and two ceramic filters in the second IF section provide the required selectivity. The second IF at 455 kHz is mixed, amplified and demodulated in the IF IC. The processing of the demodulated audio signal is performed by an audio processing IC located in the controller section.

8.1 Front-End Band-Pass Filter & Pre-Amplifier

A two pole pre-selector filter tuned by the varactor diodes D5301 and D5302 pre-selects the incoming signal (PA RX) from the antenna switch to reduce spurious effects to following stages. The tuning voltage (FE CNTL VLTG) ranging from 2 volts to 8 volts is controlled by a Digital to Analogue (D/A) converter (U0731-11) in the controller section. A dual hot carrier diode (D5303) limits any inband signal to 0 dBm to prevent damage to the pre-amplifier.

The RF pre-amplifier is an SMD device (Q5301) with collector base feedback to stabilize gain, impedance, and intermodulation. The collector current of approximately 11-16 mA is drawn from the voltage 9V3 via L5302 and R5302. A 3dB pad (R5306 - R5308 and R5317 - R5319) stabilizes the output impedance and intermodulation performance.

A second two pole varactor tuned bandpass filter provides additional filtering to the amplified signal. The varactor diodes D5304 and D5305 are controlled by the same signal which controls the pre-selector filter. A following 1 dB pad (R5310, R5314, R5316) stabilizes the output impedance and intermodulation performance

If the UHF radio is configured for a base station application, R5319 is not placed and TP5301 and TP5302 are shorted.

8.2 Mixer and Intermediate Frequency (IF) Section

The signal coming from the front-end is converted to the first IF (45.1 MHz) using a double balanced schottky diode mixer (D5401). Its ports are matched for incoming RF signal conversion to the 45.1MHz IF using low side injection. The injection signal (VCO MIXER) coming from the mixer buffer (Q5771) is filtered by the lowpass consisting of (L5403, L5404, C5401 - C5403) and has a level of approximately 10 dBm.

The mixer IF output signal (RX IF) from transformer T5401 pin 2 is fed to the first two pole crystal filter Y5201. The filter output in turn is matched to the following IF amplifier.

The IF amplifier Q5201 is actively biased by a collector base feedback (R5201, R5202) to a current drain of approximately 5 mA drawn from the voltage 5V STAB. Its output impedance is matched to the second two pole crystal filter Y5202. A dual hot carrier diode (D5201) limits the filter output voltage swing to reduce overdrive effects at RF input levels above -27 dBm.

8.3 IF IC (U5201)

The first IF signal from the crystal filters feeds the IF IC (U5201) at pin 6. Within the IF IC the 45.1MHz first IF signal mixes with the second local oscillator (LO) at 44.645MHz to the second IF at 455 kHz. The second LO uses the external crystal Y5211. The second IF signal is amplified and filtered by two external ceramic filters (FL5201, FL5202). Back in the IF IC the signal is demodulated in a phase-lock detector and fed from IF IC pin 28 to the audio processing circuit ASFIC U0201 located in the controller section (line DET AUDIO).

The squelch circuit of the IF IC is not used. Instead the squelch circuit inside the audio processing IC ASFIC (U0201) determines the squelch performance and sets the squelch threshold. The detector output signal from IF IC (U5201) pin 28 (DET_AUDIO) is fed to the ASFIC pin H7. At IF IC pin 11 an RSSI signal is available with a dynamic range of 70 dB.

The RSSI signal is interpreted by the microprocessor (U0101 pin 44) and in addition after buffering by op-amp U0202-3 available at accessory connector J0400-15.

9.0 Transmitter Power Amplifier (PA) 5-25W

The radio's 5-25 W PA is a four stage amplifier used to amplify the output from the exciter to the radio transmit level. It consists of the following four stages in the line-up. The first (Q5510) is a bipolar stage that is controlled via the PA control line (line PWR CNTL). It is followed by another bipolar stage (Q5520), a MOS FET stage (Q5530) and a final bipolar stage (Q5536).

Devices Q5510 and Q5520 are surface mounted. Bipolar Transistor Q5536 and MOS FET Q5530 are directly attached to the heat sink.

9.1 Power Controlled Stage

The first stage (Q5510) amplifies the RF signal from the VCO (line EXCITER PA) and controls the output power of the PA. The output power of the transistor Q5510 is proportional to its collector current which is adjusted by a voltage controlled current source consisting of Q5612, Q5611 and Q5621. The whole stage operates off the K9V1 source which is 9.1V in transmit mode and nearly 0V in receive mode.

The collector current of Q5510 causes a voltage drop across the resistors R5623 and R5624. Transistor Q5612 adjusts the voltage drop across R5621 controlled through the PA control line (PWR CNTL). The current source Q5621 adjusts the collector current of Q5510 by modifying its base voltage via (R5502, L5501) until the voltage drop across R5623 and R5624 plus V_{BE} (0.6V) equals the voltage drop across R5621 plus V_{BE} (0.6V) of Q5611. If the voltage of PWR CNTL is raised, the base voltage of Q5612 will also rise causing more current to flow to the collector of Q5612 and a higher voltage drop across R5621. This in turn results in more current driven into the base of Q5510 by Q5621 so that the collector current of Q5510 is increased. The collector current settles when the voltage over the series configuration of R5623 and R5624 plus V_{BE} (0.6V) of Q5621 equals the voltage over R5621 plus V_{BE} (0.6V) of Q5611.

By controlling the output power of Q5510 and in turn the input power of the following stages the ALC loop is able to regulate the output power of the transmitter. Q5611 is used for temperature compensation of the PA output power.

In receive mode the PA control line (PWR CNTL) is at ground level and switches off the collector current of Q5612 which in turn switches off the current source transistor Q5621 and the RF transistor Q5510.

9.2 PA Stages

The bipolar transistor Q5520 is driven by Q5510. To reduce the collector - emitter voltage and in turn the power dissipation of Q5510 its collector current is drawn from the antenna switch circuit.

In transmit mode the base of Q5520 is slightly positive biased by a divided K9V1 signal. This bias along with the RF signal from Q5510 allows a collector current to be drawn from the antenna switch circuit and in turn switches the antenna switch to transmit, while in receive mode the low K9V1 signal with no RF signal present cuts off the collector current and in turn switches the antenna switch to receive.

The following stage uses an enhancement mode N-Channel MOS FET device (Q5530) and requires a positive gate bias and a quiescent current flow for proper operation. The voltage of the line BIAS VLTG is set in transmit mode by a Digital to Analogue (D/A) converter (U0731-4) and fed to the gate of Q5530 via the resistive network R5521, R5522 and R5523. The bias voltage is tuned in the factory. If the transistor is replaced, the bias voltage must be tuned with the Dealer Programming Software (DPS). Care must be taken, not to damage the device by exceeding the maximum allowed bias voltage. The collector current is drawn from the supply voltage A+ via L5532.

The final stage uses the bipolar device Q5536 and operates off the A+ supply voltage. For class C operation the base is DC grounded by two series inductors (L5533, L5534). A matching network consisting of C5541-C5544 and two striplines transforms the impedance to 50 Ohms and feeds the directional coupler.

9.3 Directional Coupler

The directional coupler is a microstrip printed circuit which couples a small amount of the forward power off the RF power from Q5536. The coupled signal is rectified to an output power proportional negative DC voltage by the diode D5553 and sent to the power control circuit in the controller section via the line PWR DETECT for output power control. The power control circuit holds this voltage constant, thus ensuring the forward power out of the radio to be held to a constant value.

9.4 Antenna Switch

The antenna switch is switched synchronously with the K9V1 voltage and feeds either the antenna signal coming through the harmonic filter to the receiver or the transmitter signal coming from the PA to the antenna via the harmonic filter.

In transmit mode, this K9V1 voltage is high and biases Q5520 and along with the RF signal from Q5510 allows a collector current to be drawn. The collector current of Q5520 drawn from A+ flows via L5542, L5541, directional coupler, D5551, L5551, D5631, L5631, R5616, R5617 and L5611 and switches the PIN diodes D5551 and D5631 to the low impedance state. D5551 leads the RF signal from the directional coupler to the harmonic filter. The low impedance of D5631 is transformed to a high impedance at the input of the harmonic filter by the resonant circuit formed by L5551, C5633 and the input capacitance of the harmonic filter.

In receive mode the low K9V1 and no RF signal present from Q5510 turn off the collector current of Q5520. With no current drawn by Q5520 and resistor R5615 pulling the voltage at PIN diode D5631 to A+ both PIN diodes are switched to the high impedance state. The antenna signal, coming through the harmonic filter, is channelled to the receiver via L5551, C5634 and line PA RX.

A high impedance resonant circuit formed by D5551 in off state and L5554, C5559 prevents an influence of the receive signal by the PA stages. The high impedance of D5631 in off state doesn't influence the receiver signal.

9.5 Harmonic Filter

The transmitter signal from the antenna switch is channelled through the harmonic filter to the antenna connector J5501. The harmonic filter is formed by inductors L5552, L5553, and capacitors C5557, C5552 through C5555. This network forms a low-pass filter to attenuate harmonic energy of the transmitter to specifications level. R5550 is used for electro - static protection.

9.6 Power Control

The power control loop regulates transmitter power with an automatic level control (ALC) loop and provides protection features against excessive control voltage and high operating temperatures.

MOS FET device bias, power and control voltage limit are adjusted under microprocessor control using a Digital to Analogue (D/A) converter (U0731). The microprocessor writes the data into the D/A converter via serial interface (SRL) composed of the lines SPI CLCK SRC (clock), SPI DATA SRC (data) and DAC CE (chip enable). The D/A adjustable control voltage limit increases transmitter rise time and reduces adjacent channel splatter as it is adjusted closer to the actual operating control voltage.

The microprocessor controls K9V1 ENABLE (U0101-3) to switch on the first and the second PA stage via transistors Q0741, Q0742 and signal K9V1. The antenna switch is turned on by the collector current of the second PA stage. PA DISABLE, also microprocessor controlled (U0101-34), sets BIAS VLTG (U0731-4) and VLTG LIMIT SET (U0731-13) via Q0731, D0731 in receive mode to low to switch off the bias of the MOS FET device Q5530 and to switch off the power control voltage (PWR CNTL).

Through an Analogue to Digital (A/D) input (VLTG LIMIT) the microprocessor can read the PA control voltage (PWR CNTL) during the tuning process.

The ALC loop regulates power by adjusting the PA control line PWR CNTL to keep the forward power voltage PWR DETECT at a constant level.

Opamp U0701-2 and resistors R0701 to R0703 and R0731 subtract the negative PWR DETECT voltage from the PA PWR SET D/A output U0731 pin 2. The result is connected to opamp inverting input U0701-4 pin 9 which is compared with a 4.6 volt reference VAG present at noninverting input U0701-4 pin 10 and controls the output power of the PA via pin 8 and control line PWR CNTL. The 4.6 volt reference VAG is set by a resistive divider circuit (R0251, R0252) which is connected to ground and 9.3 volts and buffered by opamp U0251-1.

During normal transmitter operation the voltages at the opamp inputs U0701-4 pins 9 and 10 should be equal to 4.6 volts and the PA control voltage output at pin 8 should be between 4 and 7 volts. If power falls below the desired setting, PWR DETECT becomes less negative, causing the output at U0701-2 pin 7 to decrease and the opamp output U0701-4 pin 8 to increase.

A comparator formed by U0701-4 increases the PA control voltage PA CNTL until PWR DETECT is at the desired level. The power set D/A output voltage PWR SET (U0731-2) at U0701-2 pin 5 adjusts power in steps by adjusting the required value of PWR DETECT. As PA PWR SET (U0731-2) decreases, transmitter power must increase to make PWR DETECT more negative and keep the inverting input U0701-4 pin 9 at 4.6 volts.

Loop frequency response is controlled by opamp feedback components R0712 and C0711. Opamp U0701-3 compares the power control voltage PWR CNTL divided by resistors R0717 to R0719 with the voltage limit setting VLTG LIMIT SET from the D/A converter (U0731-13) and keeps the control voltage constant via Q0711 if the control voltage, reduced by the resistive divider (R0717 to R0719), approaches the voltage of VLTG LIMIT SET (U0731-13).

Rise and fall time of the output power during transmitter keying and dekeying is controlled by the comparator formed by opamp U0701-3.

During normal transmitter operation the voltage at U0701-3 pin 13 is higher than the voltage at pin 12 causing the output at pin 14 being low and switching off transistor Q0711. Diode D0732 reduces the bias voltage BIAS VLTG for low control voltage levels.

The temperature of the PA area is monitored by opamp U0701-1 using thermistor R5641 (located in the PA section). If the temperature increases, the resistance of the thermistor decreases, decreasing the voltage PA TEMP. The inverting amplifier formed by U0701-1 amplifies the PA TEMP voltage and if the voltage at opamp pin 1 approaches 4.6 V plus the voltage (ON) across D0721, U0701-1 simulates an increased power which in turn decreases the power control voltage until the voltage at U0701-4 pin 9 is 4.6V again. Resistor R0724, R0722, R0723 set the factor of the decrease in output power per temperature increase while R0721 through R0723 set the threshold where the temperature starts reducing the output power. During normal transmitter operation the output voltage of opamp U0701-1 pin 1 is below 4.6V. Diode D5601 located in the PA section acts as protection against transients and wrong polarity of the supply voltage.

10.0 Frequency Synthesis

The complete synthesizer subsystem consists of the Reference Oscillator (Y5701 or U5702), the Fractional-N synthesizer (U5701), the Voltage Controlled Oscillator (Q5741), the RX and TX buffer stages (Q5751, Q5771, Q5781) and the feedback amplifier (Q5791).

10.1 Reference Oscillator

The Reference Oscillator (Y5702) contains a temperature compensated crystal oscillator with a frequency of 16.8 MHz. An Analogue to Digital (A/D) converter internal to U5701 (FRAC-N) and controlled by the microprocessor via serial interface (SRL) sets the voltage at the warp output of U5701 pin 16 to set the frequency of the oscillator. The output of the oscillator (pin 2 of Y5702) is applied to pin 14 (XTAL1) of U5701 via a RC series combination.

Some models use the Reference Oscillator U5702 instead of Y5702. The Reference Oscillator (U5702) contains a temperature compensated crystal oscillator with a frequency of 16.8 MHz. This oscillator is tuned by a temperature referenced 5 bit Analogue to Digital (A/D) converter. The output of the oscillator (pin 10 of U5702) is applied to pin 14 (XTAL1) of U5701 via a RC series combination. The serial interface (SRL) for control is connected to the μ P via the data line SPI DATA (U5702-25), clock line SPI CLK (U5702-22), and chip enable line PEND CE (U5702-24).

In applications where less frequency stability is required the oscillator inside U5701 is used along with an external crystal Y5701, the varactor diode D5702, C5708, C5710 and R5704. The crystal may not be replaced in case of failure. Instead of the crystal, the reference oscillator Y5702 must be soldered in along with C5706, C5707, R5703. Components Y5701, C5708, C5710, R5704, D5702 must be removed and the value of C5709 must be changed. Afterwards the radio must be retuned.

10.2 Fractional-N Synthesizer (U5701)

The FRAC-N synthesizer IC (U5701) consists of a pre-scaler, a programmable loop divider, control divider logic, a phase detector, a charge pump, an A/D converter for low frequency digital modulation, a balance attenuator to balance the high frequency analogue modulation and low frequency digital modulation, a 13V positive voltage multiplier, a serial interface for control, and finally a super filter for the regulated 9.3 volts.

A voltage of 9.3V applied to the super filter input (U5701 pin 19) supplies an output voltage of 8.6 VDC at pin 18. It supplies the VCO (Q5741), VCO modulation bias circuit (via R5714) and the synthesizer charge pump resistor network (R5723, R5724, R5726). The synthesizer supply voltage is provided by the 5V regulator U5801.

In order to generate a high voltage to supply the phase detector (charge pump) output stage at pin VCP (U5701-32), a voltage of 13 VDC is being generated by the positive voltage multiplier circuitry (D5701-1-3, C5716, C5717). This voltage multiplier is basically a diode capacitor network driven by two (1.05MHz) 180 degrees out of phase signals (U5701-9 and -10).

Output LOCK (U5701-2) provides information about the lock status of the synthesizer loop. A high level at this output indicates a stable loop. IC U5701 divides the 16.8 MHz reference frequency down to 2.1 MHz and provides it at pin 11. This signal is used as clock signal by the controller.

The serial interface (SRL) is connected to the microprocessor via the data line SPI DATA (U5701-5), clock line SPI CLK (U5701-6), and chip enable line FRACN CE (U5701-7).

10.3 Voltage Controlled Oscillator (VCO)

The Voltage Controlled Oscillator (VCO) is formed by the colpitts oscillator FET Q5741. Q5741 draws a drain current of 12 mA from the FRAC-N IC super filter output. The oscillator frequency is half of the desired frequency and mainly determined by L5743, C5742, C5743, C5745 - C5748 and varactor diodes D5741 / D5742. Diode D5743 controls the amplitude of the oscillator.

A balanced frequency doubler T5751, D5751 converts the oscillator fundamental to the desired UHF frequency. With a steering voltage from 2.5V to 10.5V at the varactor diodes the full RX and TX frequency range from 357.9 MHz to 470 MHz is covered.

After the doubler a 3-pole bandpass filter rejects unwanted harmonics at the first and third oscillator fundamental frequency and matches the output to the Common VCO Buffer Q5751. Q5751 draws a collector current of 13 mA from the stabilized 5V (U5801) and drives the Pre-scaler Buffer Q5791, the PA Buffer Q5781 (Pout = 13dBm) and Mixer Buffer Q5771 (Pout = 10dBm). Q5791 draws a collector current of 8 mA from the stabilized 5V and Q5771, Q5781 both draw 17mA from the 9V3 source. The buffer stages Q5771, Q5781 and the feedback amplifier Q5791 provide the necessary gain and isolation for the synthesizer loop.

Q5731 is controlled by output AUX3 of U5701 (pin 1) and enables the RX or TX buffer. In RX mode AUX3 is nearly at ground level, in TX mode about 5V DC. In TX mode with R5732 pulled to ground level by Q5731 the modulation signal coming from the FRAC-N synthesizer IC (U5701 pin28) modulates the VCO via varactor diode D5731 while in RX mode the modulation circuit is disabled by pulling R5732 to a higher level through R5772.

10.4 Synthesizer Operation

The complete synthesizer subsystem works as follows. The output signal of the VCO (Q5741) is frequency doubled by doubler D5751 and, buffered by Common VCO Buffer Q5751. To close the synthesizer loop, the collector of Q5791 is connected to the PREIN port of synthesizer U5701 (pin 20). The buffer output (Q5751) also provides signals for the Mixer Buffer Q5771 and the PA Buffer (Q5781).

The pre-scaler in the synthesizer (U5701) is basically a dual modulus pre-scaler with selectable divider ratios. This divider ratio of the pre-scaler is controlled by the loop divider, which in turn receives its inputs via the SRL. The output of the pre-scaler is applied to the loop divider. The output of the loop divider is connected to the phase detector, which compares the loop divider's output signal with the reference signal. The reference signal is generated by dividing down the signal of the reference oscillator (Y5702 or Y5701).

The output signal of the phase detector is a pulsed DC signal which is routed to the charge pump. The charge pump outputs a current at pin 29 (I OUT of U5701). The loop filter (which consists of R5715-R5717, C5723-C5725, C5727, R5741, C5741) transforms this current into a voltage that is applied to the varactor diodes D5741, D5742 and alters the output frequency of the VCO (Q5741). The current can be set to a value fixed in the FRAC-N IC or to a value determined by the currents flowing into CPBIAS 1 (U5701-27) or CPBIAS 2 (U5701-26). The currents are set by the value of R5724 or R5726 respectively. The selection of the three different bias sources is done by software programming.

To reduce synthesizer lock time when new frequency data has been loaded into the synthesizer the magnitude of the loop current is increased by enabling the IADAPT line (U5701-31) for a certain software programmable time (Adapt Mode). The adapt mode timer is started by a low to high transient of the FRACN CE line. When the synthesizer is within the lock range the current is determined only by the resistors connected to CPBIAS 1, CPBIAS 2, or the internal current source. A settled synthesizer loop is indicated by a high level of signal LOCK DET (U5701-2).

LOCK DET adds up with signal SQ DET, weighted by resistors R0113, R0114, and is routed to one of the μP 's ADCs input U0101-43. From the voltage weighted by the resistors the μP determines whether SQ DET, LOCK DET or both are active.

In order to modulate the PLL the two spot modulation method is utilized. Via pin 8 (MODIN) on U5701 the audio signal is applied to both the A/D converter (low freq path) as well as the balance attenuator (high freq path). The A/D converter converts the low frequency analogue modulating signal into a digital code that is applied to the loop divider, thereby causing the carrier to deviate. The balance attenuator is used to adjust the VCO's deviation sensitivity to high frequency modulating signals. The output of the balance attenuator is present at the MODOUT port (U5701-28) and connected to the VCO modulation diode D5731 via L5731, C5732.

VHF (136-174MHz) SPECIFIC CIRCUIT DESCRIPTION

11.0 Receiver Front-End

The receiver is able to cover the VHF range from 136 to 174 MHz. It consists of four major blocks: front-end, mixer, first IF section and IF IC. Antenna signal pre-selection is performed by two varactor tuned bandpass filters. A double balanced schottky diode mixer converts the signal to the first IF at 45.1 MHz.

Two crystal filters in the first IF section and two ceramic filters in the second IF section provide the required selectivity. The second IF at 455 kHz is mixed, amplified and demodulated in the IF IC. The processing of the demodulated audio signal is performed by an audio processing IC located in the controller section.

11.1 Front-End Band-Pass Filter and Pre-Amplifier

A two pole pre-selector filter tuned by the dual varactor diode D3301 pre-selects the incoming signal (PA RX) from the antenna switch to reduce spurious effects to following stages. The tuning voltage (FE CNTL VLTG) ranging from 2 volts to 8 volts is controlled by a Digital to Analogue (D/A) converter (U0731-11) in the controller section. A dual hot carrier diode (D3303) limits any inband signal to 0dBm to prevent damage to the pre-amplifier.

The RF pre-amplifier is an SMD device (Q3301) with collector base feedback to stabilize gain, impedance, and intermodulation. The collector current of approximately 11-16 mA, drawn from the voltage 9V3 via L3302, is controlled by a current source composed of Q3302, R3302, R3300, and R3311 - R3313. In transmit mode the high K9V1 signal fed through diode D3300 switches off the current source and in turn the pre-amplifier. In receive mode K9V1 must be low to switch on the current source. A 3 dB pad (R3306 - R3308 and R3316 - R3318) stabilizes the output impedance and intermodulation performance.

A second two pole varactor tuned bandpass filter provides additional filtering to the amplified signal. The dual varactor diode D3304 is controlled by the same signal which controls the pre-selector filter.

If the radio is configured for a base station application, R3318 is not placed and TP3301 and TP3302 are shorted.

11.2 Mixer and Intermediate Frequency (IF) Section

The signal coming from the front-end is converted to the first IF (45.1 MHz) using a double balanced schottky diode mixer (D3331). Its ports are matched for incoming VHF signal conversion to the 45.1MHz IF using high side injection. The injection signal (VCO MIXER) coming from the mixer buffer (Q3770) is filtered by the lowpass consisting of (L3333, L3334, C3331 - C3333) and has a level of approximately 10 dBm.

The mixer IF output signal (RX IF) from transformer T3301 pin 2 is fed to the first two pole crystal filter Y5201. The filter output in turn is matched to the following IF amplifier.

The IF amplifier Q5201 is actively biased by a collector base feedback (R5201, R5202) to a current drain of approximately 5 mA drawn from the voltage 5V STAB. Its output impedance is matched to the second two pole crystal filter Y5202. A dual hot carrier diode (D5201) limits the filter output voltage swing to reduce overdrive effects at RF input levels above -27 dBm.

11.3 IF IC (U5201)

The first IF signal from the crystal filters feeds the IF IC (U5201) at pin 6. Within the IF IC the 45.1MHz first IF signal mixes with the second local oscillator (LO) at 44.645MHz to the second IF at 455 kHz. The second LO uses the external crystal Y5211. The second IF signal is amplified and filtered by two external ceramic filters (FL5201, FL5202). Back in the IF IC the signal is demodulated in a phase-lock detector and fed from IF IC pin 28 to the audio processing circuit ASFIC U0201 located in the controller section (line DET AUDIO).

The squelch circuit of the IF IC is not used. Instead the squelch circuit inside the audio processing IC ASFIC (U0201) determines the squelch performance and sets the squelch threshold. The detector output signal from IF IC (U5201) pin 28 (DET AUDIO) is fed to the ASFIC pin H7.

At IF IC pin 11 an RSSI signal is available with a dynamic range of 70 dB. The RSSI signal is interpreted by the microprocessor (U0101 pin 44) and in addition after buffering by op-amp U0202-3 available at accessory connector J0400-15.

12.0 Transmitter Power Amplifier (PA) 5-25W

The radio's 5-25 W PA is a three stage amplifier used to amplify the output from the exciter to the radio transmit level. It consists of the following stages in the line-up. The first (Q3511) is a bipolar stage that is controlled via the PA control line (line PWR CNTL). It is followed by a MOS FET stage (Q3521) and a final bipolar stage (Q3531). Devices Q3511 and Q3521 are surface mounted. Bipolar Transistor Q3531 is directly attached to the heat sink.

12.1 Power Controlled Stage

The first stage (Q3511) amplifies the RF signal from the VCO (line EXCITER PA) and controls the output power of the PA. The output power of the transistor Q3511 is proportional to its collector current which is adjusted by a voltage controlled current source consisting of Q3641, (Q3643-T3 only) and Q3642. The current of the whole stage is drawn from the RX-TX Switch through coil L3652.

Transistor Q3643 (not in all models), controlled by the microprocessor via signal K9V1, switches the current source on in transmit mode and off in receive mode.

The collector current of Q3511, drawn via L3511/L3641, causes a voltage drop across the resistors R3645 and R3646. Transistor Q3641 adjusts the voltage drop across R3644 controlled through the PA control line (PWR CNTL). The current source Q3642 adjusts the collector current of Q3511 by modifying its base voltage via R3647 until the voltage drop across R3645 and R3646 plus V_{BE} (0.6V) equals the voltage drop across R3644. If the voltage of PWR CNTL is raised, the base voltage of Q3641 will also rise causing more current to flow to the collector of Q3641 and a higher voltage drop across R3644. This in turn results in more current driven into the base of Q3511 by Q3642 so that the current of Q3511 is increased. The collector current settles when the voltage over the series configuration of R3645 and R3646 plus V_{BE} of Q3642 equals the voltage over R3644. By controlling the output power of Q3511 and in turn the input power of the following stages the ALC loop is able to regulate the output power of the transmitter.

In receive mode the PA control line (PWR CNTL) is at ground level and switches off the collector current of Q3641 which in turn switches off the current source transistor Q3642 and the RF transistor Q3511.

12.2 PA Stages

The following stage uses an enhancement mode N-Channel MOS FET device (Q3521) and requires a positive gate bias and a quiescent current flow for proper operation. The voltage of the line BIAS VLTG is set in transmit mode by a Digital to Analogue (D/A) converter (U0731-4) and fed to the gate of Q3521 via the resistive network R3613, R3614, R3615. The bias voltage is tuned in the factory. If the transistor is replaced, the bias voltage must be tuned with the Dealer Programming Software (DPS). Care must be taken, not to damage the device by exceeding the maximum allowed bias voltage. The collector current is drawn from the supply voltage A+ via L3622.

The final stage uses the bipolar device Q3531 and operates off the A+ supply voltage. For class C operation the base is DC grounded by two series inductors (L3521, L3522). A matching network consisting of C3530-C3534, L3532, L3533 and two striplines transforms the impedance to 50 Ohms and feeds the directional coupler.

12.3 Directional Coupler

The directional coupler is a microstrip printed circuit which couples a small amount of the forward power off the RF power from Q3531. The coupled signal is rectified to an output power proportional negative DC voltage by the diode D3657 and sent to the power control circuit in the controller section via the line PWR DETECT for output power control. The power control circuit holds this voltage constant, thus ensuring the forward power out of the radio to be held to a constant value.

12.4 Antenna Switch

The antenna switch is switched synchronously with the K9V1 voltage along with the voltage PWR CNTL signal and feeds either the antenna signal coming through the harmonic filter to the receiver or the transmitter signal coming from the PA to the antenna via the harmonic filter.

In transmit mode, this PWR CNTL is above 1 V and biases Q3511 through Q3641 and Q3642 to allow a collector current to be drawn. The collector current of Q3511 drawn from A+ flows via L3631, L3531, L3532, L3533, directional coupler, D3551, L3651, D3651, L3652, R3645, R3646, L3641, L3511 and switches the PIN diodes D3551 and D3651 to the low impedance state. D3551 leads the RF signal from the directional coupler to the harmonic filter. The low impedance of D3651 is transformed to a high impedance at the input of the harmonic filter by the resonant circuit formed by L3651, C3652 and the input capacitance of the harmonic filter.

Transistor Q3643, controlled by the microprocessor via Signal K9V1, is used to switch the collector current of Q3641 on in transmit mode and off in receive mode. In receive mode the low K9V1 and the low PWR CNTL turn off the collector current of Q3511 through Q3641 and Q3642. With no current drawn by Q3511 and resistor R3651 pulling the voltage at PIN diode D3651 to A+ both PIN diodes are switched to the high impedance state. The antenna signal, coming through the harmonic filter, is channelled to the receiver via L3651, C3651 and line PA RX. The high impedance of D3551/D3651 in off state does not influence the receiver signal.

12.5 Harmonic Filter

The transmitter signal from the antenna switch is channelled through the harmonic filter to the antenna connector J3501. The harmonic filter is formed by inductors L3551, L3552, and capacitors C3551 through to C3554. This network forms a low-pass filter to attenuate harmonic energy of the transmitter to specifications level. R3551 is used for electro-static protection.

12.6 Power Control

The power control loop regulates transmitter power with an automatic level control (ALC) loop and provides protection features against excessive control voltage and high operating temperatures.

MOS FET device bias, power and control voltage limit are adjusted under microprocessor control using a Digital to Analogue (D/A) converter (U0731). The microprocessor writes the data into the D/A converter via serial interface (SRL) composed of the lines SPI CLCK SRC (clock), SPI DATA SRC (data) and DAC CE (chip enable). The D/A adjustable control voltage limit increases transmitter rise time and reduces adjacent channel splatter as it is adjusted closer to the actual operating control voltage.

The microprocessor controls K9V1 ENABLE (U0101-3) to switch on the first PA stage via transistors Q0741, Q0742 and signal K9V1. The antenna switch is turned on by the collector current of the first PA stage. PA DISABLE, also microprocessor controlled (U0101-34), sets BIAS VLTG (U0731-4) and VLTG LIMIT SET (U0731-13) via Q0731, D0731 in receive mode to low to switch off the bias of the MOS FET device Q3521 and to switch off the power control voltage (PWR CNTL).

Through an Analogue to Digital (A/D) input (VLTG LIMIT) the microprocessor can read the PA control voltage (PWR CNTL) during the tuning process.

The ALC loop regulates power by adjusting the PA control line PWR CNTL to keep the forward power voltage PWR DETECT at a constant level.

Opamp U0701-2 and resistors R0701 to R0703 and R0731 subtract the negative PWR DETECT voltage from the PA PWR SET D/A output U0731 pin 2. The result is connected to opamp inverting input U0701-4 pin 9 which is compared with a 4.6 volt reference VAG present at noninverting input U0701-4 pin 10 and controls the output power of the PA via pin 8 and control line PWR CNTL. The 4.6 volt reference VAG is set by a resistive divider circuit (R0251, R0252) which is connected to ground and 9.3 volts and buffered by opamp U0251-1.

During normal transmitter operation the voltages at the opamp inputs U0701-4 pins 9 and 10 should be equal to 4.6 volts and the PA control voltage output at pin 8 should be between 4 and 7 volts. If power falls below the desired setting, PWR DETECT becomes less negative, causing the output at U0701-2 pin 7 to decrease and the opamp output U0701-4 pin 8 to increase.

A comparator formed by U0701-4 increases the PA control voltage PA CNTL until PWR DETECT is at the desired level. The power set D/A output voltage PWR SET (U0731-2) at U0701-2 pin 5 adjusts power in steps by adjusting the required value of PWR DETECT. As PWR SET (U0731-2) decreases, transmitter power must increase to make PWR DETECT becomes more negative and keep the inverting input U0701-4 pin 9 at 4.6 volts.

Loop frequency response is controlled by opamp feedback components R0712 and C0711. Opamp U0701-3 compares the power control voltage PWR CNTL divided by resistors R0717 to R0719 with the voltage limit setting VLTG LIMIT SET from the D/A converter (U0731-13) and keeps the control voltage constant via Q0711 if the control voltage, reduced by the resistive divider (R0717 to R0719), approaches the voltage of VLTG LIMIT SET (U0731-13).

Rise and fall time of the output power during transmitter keying and dekeying is controlled by the comparator formed by opamp U0701-3.

During normal transmitter operation the voltage at U701-3 pin 13 is higher than the voltage at pin 12 causing the output at pin 14 being low and switching off transistor Q0711. Diode D0732 reduces the bias voltage BIAS VLTG for low control voltage levels.

The temperature of the PA area is monitored by opamp U0701-1 using thermistor R3611 (located in the PA section). If the temperature increases, the resistance of the thermistor decreases, decreasing the voltage PA TEMP. The inverting amplifier formed by U0701-1 amplifies the PA TEMP voltage and if the voltage at opamp pin 1 approaches 4.6 V plus the voltage (ON) across D0721, U701-1 simulates an increased power which in turn decreases the power control voltage until the voltage at U0701-4 pin 9 is 4.6V again. Resistor R0724, R0722, R0723 set the factor of the decrease in output power per temperature increase while R0721 through R0723 set the threshold were the temperature starts reducing the output power. During normal transmitter operation the output voltage of opamp U701-1 pin 1 is below 4.6V. Diode D3601 located in the PA section acts as protection against transients and wrong polarity of the supply voltage.

13.0 Frequency Synthesis

The complete synthesizer subsystem consists of the Reference Oscillator (Y3701 or Y3702), the Fractional-N synthesizer (U3701), the Voltage Controlled Oscillator (Q3741, Q3751), the RX and TX buffer stages (Q3760, Q3770, Q3780) and the feedback amplifier (Q3790).

13.1 Reference Oscillator

The Reference Oscillator (Y3702) contains a temperature compensated crystal oscillator with a frequency of 16.8 MHz. An Analogue to Digital (A/D) converter internal to U3701 and controlled by the microprocessor via serial interface (SRL) sets the voltage at the warp output of U3701 pin 16 to set the frequency of the oscillator. The output of the oscillator (pin 2 of Y3702) is applied to pin 14 (XTAL1) of U3701 via a RC series combination.

In applications where less frequency stability is required the oscillator inside U3701 is used along with an external crystal Y3701, the varactor diode D3702, C3708, C3710 and R3704. The crystal may not be replaced in case of failure. Instead of the crystal, the reference oscillator Y3702 must be soldered in along with C3706, C3707, R3703. Components Y3701, C3708, C3710, R3704, D3702 must be removed and the value of C3709 must be changed. Afterwards the radio must be retuned.

13.2 Fractional-N Synthesizer (U3701)

The FRAC-N synthesizer IC (U3701) consists of a pre-scaler, a programmable loop divider, control divider logic, a phase detector, a charge pump, an A/D converter for low frequency digital modulation, a balance attenuator to balance the high frequency analogue modulation and low frequency digital modulation, a 13V positive voltage multiplier, a serial interface for control, and finally a super filter for the regulated 9.3 volts.

A voltage of 9.3V applied to the super filter input (U3701 pin 19) supplies an output voltage of 8.6 VDC at pin 18. It supplies the VCO (Q3741 / Q3751), VCO modulation bias circuit (R3714) and the synthesizer charge pump resistor network (R3723, R3724). The synthesizer supply voltage is provided by the 5V regulator U3801.

In order to generate a high voltage to supply the phase detector (charge pump) output stage at pin VCP (U3701-32), a voltage of 13 VDC is being generated by the positive voltage multiplier circuitry (D3701-1-3, C3716, C3717). This voltage multiplier is basically a diode capacitor network driven by two (1.05 MHz) 180 degrees out of phase signals (U3701-9 and -10).

Output LOCK (U3701-2) provides information about the lock status of the synthesizer loop. A high level at this output indicates a stable loop. IC U3701 divides the 16.8 MHz reference frequency down to 2.1 MHz and provides it at pin 11. This signal is used as clock signal by the controller.

The serial interface (SRL) is connected to the microprocessor via the data line SPI DATA (U3701-5), clock line SPI CLK (U3701-6), and chip enable line FRACN CE (U3701-7).

13.3 Voltage Controlled Oscillator (VCO)

The Voltage Controlled Oscillator (VCO) uses 2 colpitts oscillators, FET Q3741 for transmit and FET Q3751 for receive. The appropriate oscillator is switched on or off by FRAC-N IC output AUX3 (U3701-1) using transistors Q3742 and Q3752. In RX mode AUX3 is nearly at ground level and Q3742 enables a current flow from the source of FET Q3751 while Q3752 is switched off.

In TX mode AUX3 is about 5V DC and Q3742 is switched off. Q3752 is switched on and enables a current flow from the source of FET Q3741 while Q3751 is switched off. When switched on the FETs draw a drain current of 8 mA from the FRAC-N IC super filter output. The frequency of the receive oscillator is mainly determined by L3752, C3752, C3754 - C3756 and varactor diodes D3751 / D3752. Diode D3754 controls the amplitude of the oscillator. The frequency of the transmit oscillator is mainly determined by L3734, C3736 - C3740 and varactor diodes D3732 / D3733. Diode D3739 controls the amplitude of the oscillator. With a steering voltage from 3V to 10V at the varactor diodes the RX frequency range from 181.1MHz to 219.1MHz and the TX frequency range from 136MHz to 174MHz are covered. In TX mode the modulation signal coming from the FRAC-N synthesizer IC (U3701 pin 28) modulates the TX VCO via varactor diode D3731.

Both oscillator outputs are combined and buffered by the VCO Buffer Q3760. Q3760 draws a collector current of 13 mA from the stabilized 5V (U3801) and drives the Mixer Buffer Q3770. Q3770 draws a collector current of 17 mA from the 9V3 voltage and drives the PA Buffer Q3780 (Pout = 13dBm) and the Pre-scaler Buffer Q3790. Q3790 draws a collector current of 8 mA from the stabilized 5V (U3801) and drives the pre-scaler internal to the FRAC-N IC. In transmit mode Q3780 is switched on by the K9V1 signal and draws a collector current of 19 mA from the K9V1 voltage. The injection signal VCO MIXER with a level of 10dBm feeds the mixer through R3774. The buffer stages Q3760, Q3770, Q3780 and the feedback amplifier Q3790 provide the necessary gain and isolation for the synthesizer loop.

13.4 Synthesizer Operation

The complete synthesizer subsystem works as follows. The combined output signal of the RX VCO (Q3751) and TX VCO (Q3741) is buffered by VCO Buffer Q3760, Mixer Buffer Q3770 and Pre-scaler Buffer Q3790. To close the synthesizer loop, the collector of Q3790 is connected to the PREIN port of synthesizer U3701 (pin 20). The output of the VCO Buffer (Q3770) also provides signals for the mixer (via VCO MIXER) and the PA Buffer (Q3780).

The pre-scaler in the synthesizer (U3701) is basically a dual modulus pre-scaler with selectable divider ratios. This divider ratio of the pre-scaler is controlled by the loop divider, which in turn receives its inputs via the SRL. The output of the pre-scaler is applied to the loop divider. The output of the loop divider is connected to the phase detector, which compares the loop divider's output signal with the reference signal. The reference signal is generated by dividing down the signal of the reference oscillator (Y3701 or Y3702).

The output signal of the phase detector is a pulsed DC signal which is routed to the charge pump. The charge pump outputs a current at pin 29 (I OUT of U3701). The loop filter (which consists of R3715 - R3718, C3723 - C3725, C3727, C3735) transforms this current into a voltage that is applied to the varactor diodes D3732, D3733 (TX), D3751, D3752 (RX) and alters the output frequency of the TX VCO (Q3741) and RX VCO (Q3751). The current can be set to a value fixed in the FRAC-N IC or to a value determined by the current flowing into CPBIAS 1 (U3701-27). The current is set by the value of R3723 and R3724. The selection of the two different bias sources is done by software programming.

To reduce synthesizer lock time when new frequency data has been loaded into the synthesizer the magnitude of the loop current is increased by enabling the IADAPT line (U3701-31) for a certain software programmable time (Adapt Mode). The adapt mode timer is started by a low to high transient of the FRACN CE line. When the synthesizer is within the lock range the current is determined only by the resistors connected to CPBIAS 1 or the internal current source.

A settled synthesizer loop is indicated by a high level of signal LOCK DET (U3701-2).

LOCK DET adds up with signal SQ DET, weighted by resistors R0113, R0114, and is routed to one of the μ P's ADCs input U0101-43. From the voltage weighted by the resistors the μ P determines whether SQ DET, LOCK DET or both are active.

In order to modulate the PLL the two spot modulation method is utilized. Via pin 8 (MODIN) on U3701 the audio signal is applied to both the A/D converter (low freq path) as well as the balance attenuator (high freq path). The A/D converter converts the low frequency analogue modulating signal into a digital code that is applied to the loop divider, thereby causing the carrier to deviate. The balance attenuator is used to adjust the VCO's deviation sensitivity to high frequency modulating signals. The output of the balance attenuator is present at the MODOUT port (U3701-28) and connected to the VCO modulation diode D3731 via L3731, C3733.

Chapter 3.2

PCB/Schematic Diagrams and Parts Lists

Table of Contents

Description	Page
<i>PCB Overlays</i>	
UHF (403-430MHz)PCB 8486072B01_T1	
Layout Top Side	1
Layout Bottom Side	2
VHF (136-174MHz) PCB 8486069B01_T1	
Layout Top Side	3
Layout Bottom Side	4
<i>Controller Schematic Diagrams</i>	
Open Controller Schematic Diagram 1 of 3	5
Open Controller_AUDIO Schematic Diagram 2 of 3	7
Open Controller_IO Schematic Diagram 3 of 3	9
Parts List	6/8/10
Supply Voltage Schematic Diagram	11
Parts List	12
<i>UHF (403-470MHz) Schematic Diagrams and Parts Lists</i>	
Power Control Schematic Diagram	13
Parts List	14
Power Amplifier 5-25W Schematic Diagram	15
Parts List	16
Synthesizer Schematic Diagram	17
Parts List	18
Voltage Controlled Oscillator Schematic Diagram	19
Parts List	20

Description	Page
RX-FE Schematic Diagram	21
Parts List.	22
RX-IF Schematic Diagram.	23
Parts List.	24
 <i>VHF (136-174MHz) Schematic Diagrams and Parts Lists</i>	
Power Control Schematic Diagram.	25
Parts List.	26
Power Amplifier 5-25W Schematic Diagram.	27
Parts List.	28
Synthesizer Schematic Diagram	29
Parts List.	30
Voltage Controlled Oscillator Schematic Diagram	31
Parts List.	32
RX-FE Schematic Diagram	33
Parts List.	34
RX-IF Schematic Diagram.	35
Parts List.	36

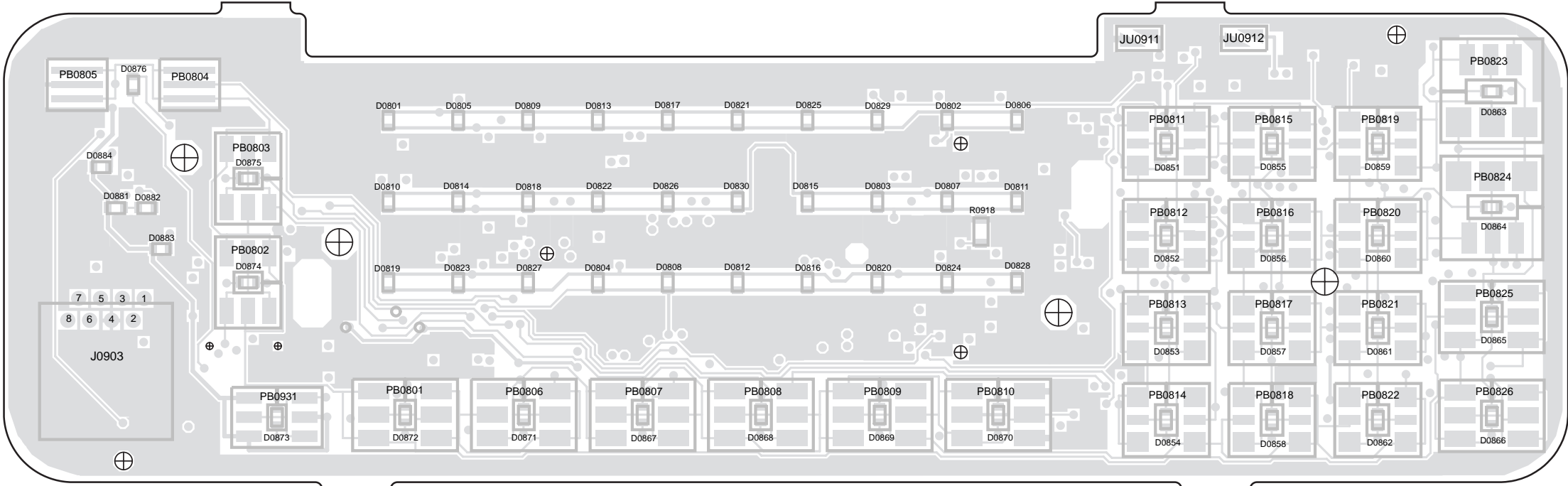

Top Side

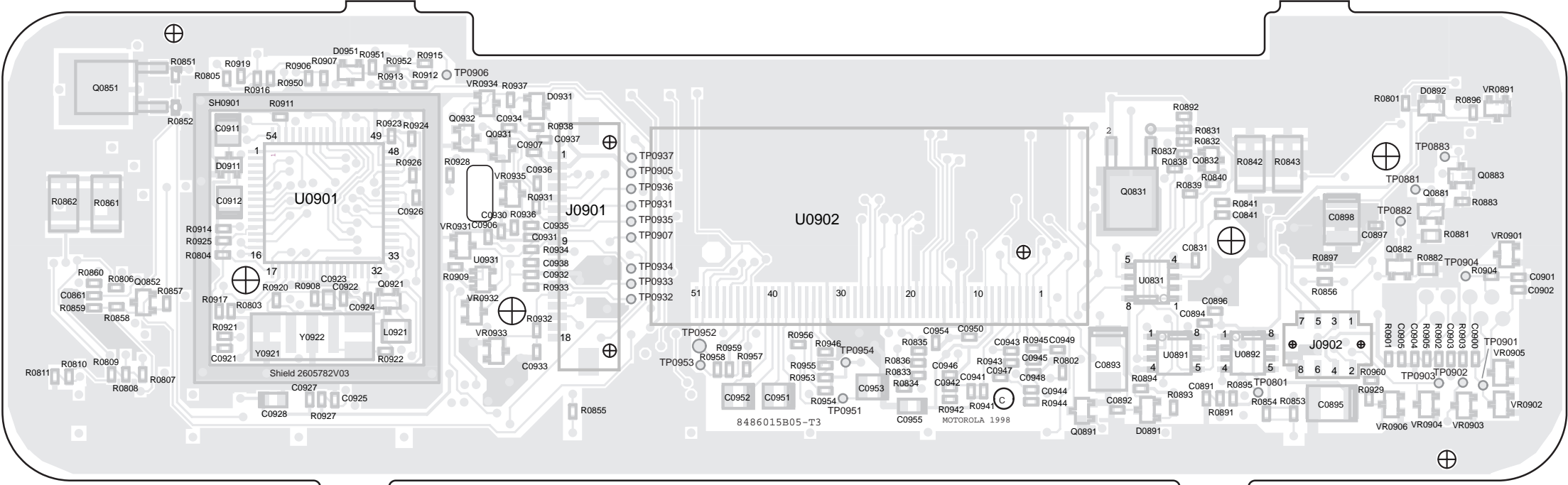

Bottom Side

Display/Keypad Radio Control Head Schematic Diagram

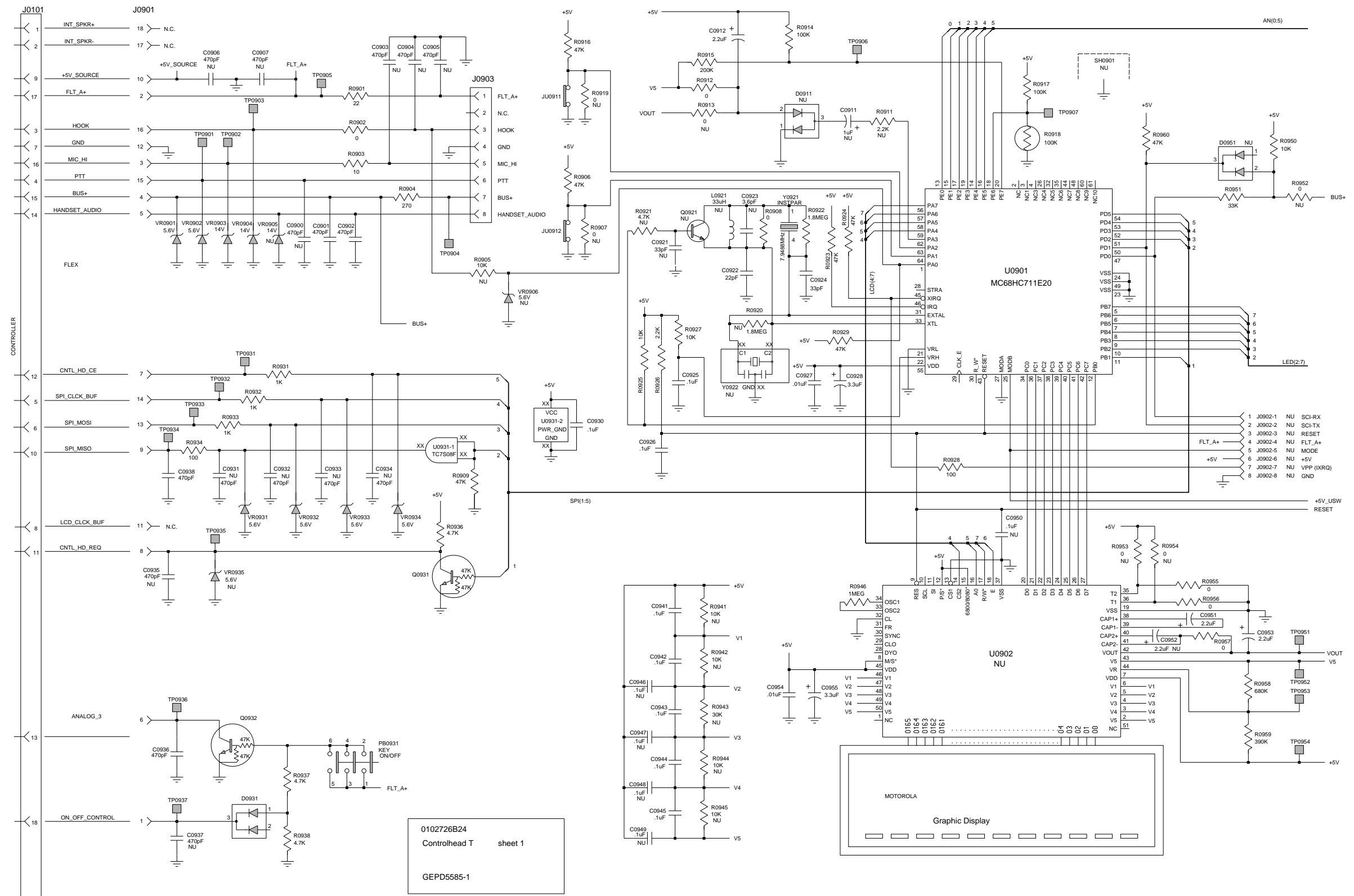

0102726B24
Controlhead T sheet 1
GEPD5585-1

Display/Keypad Radio Control Head Schematic Diagram 1 of 2

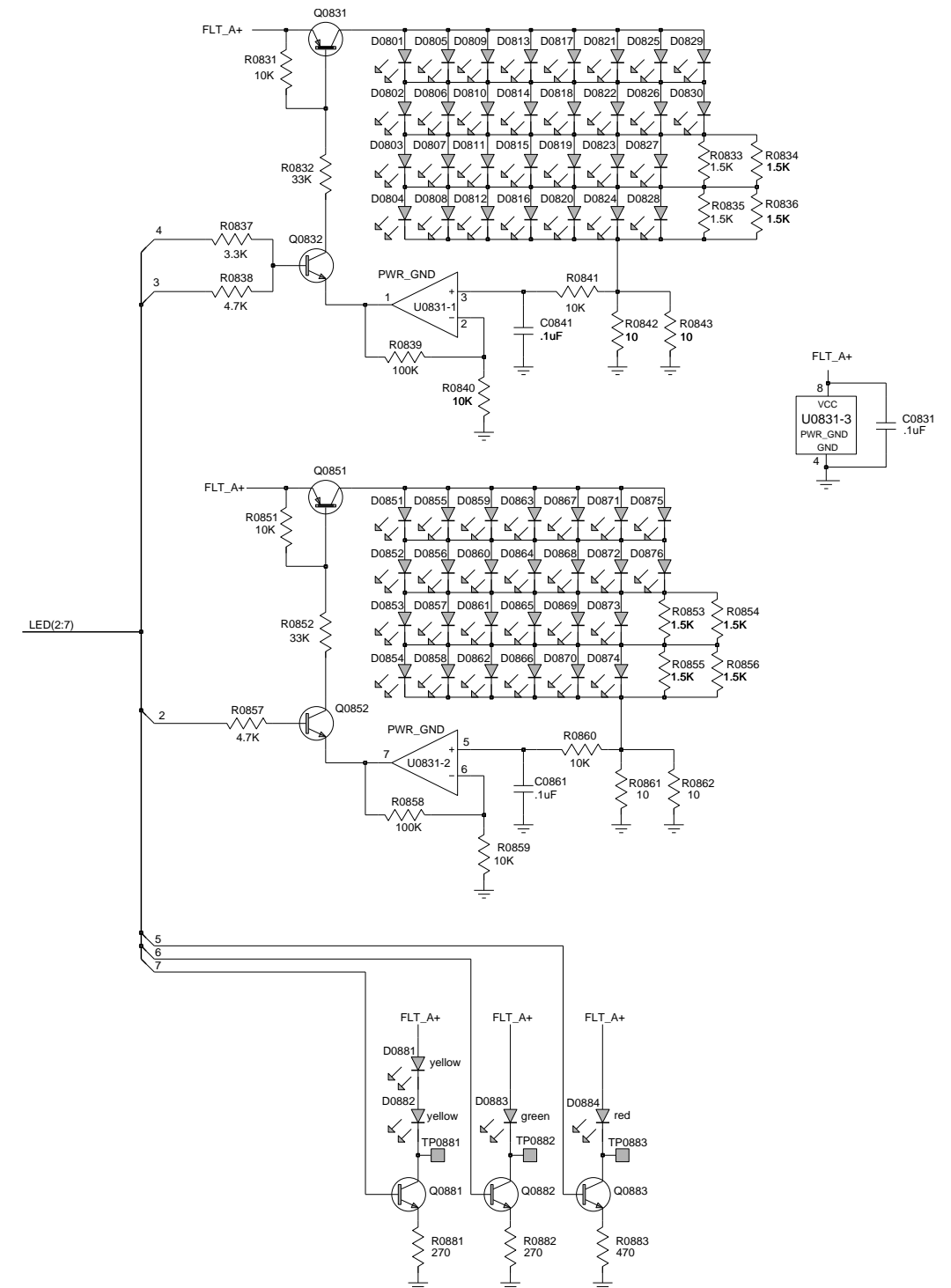
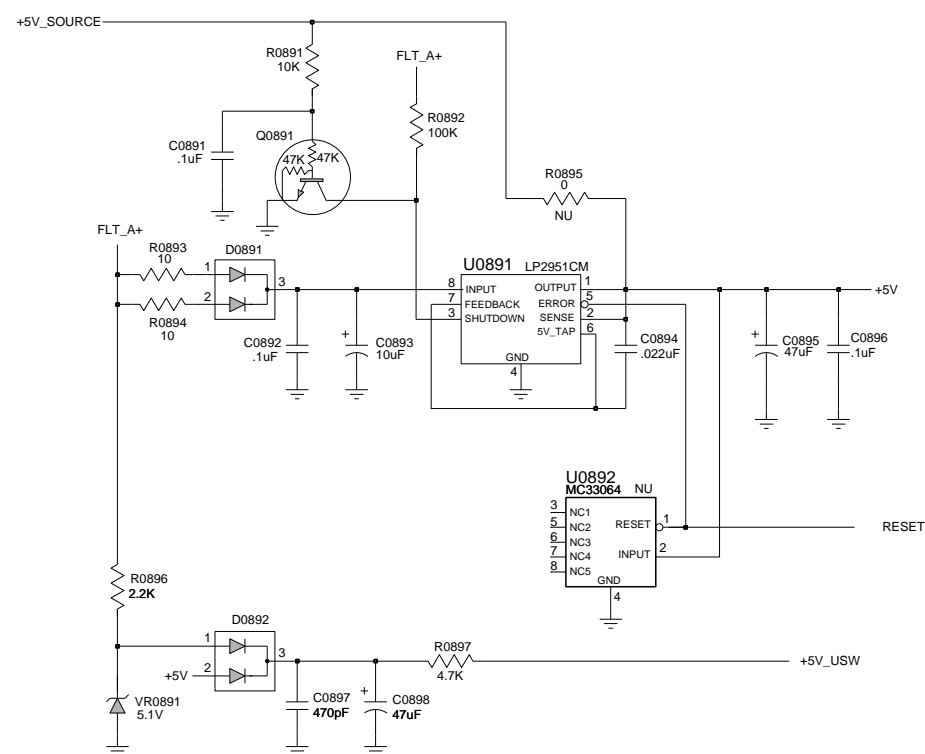
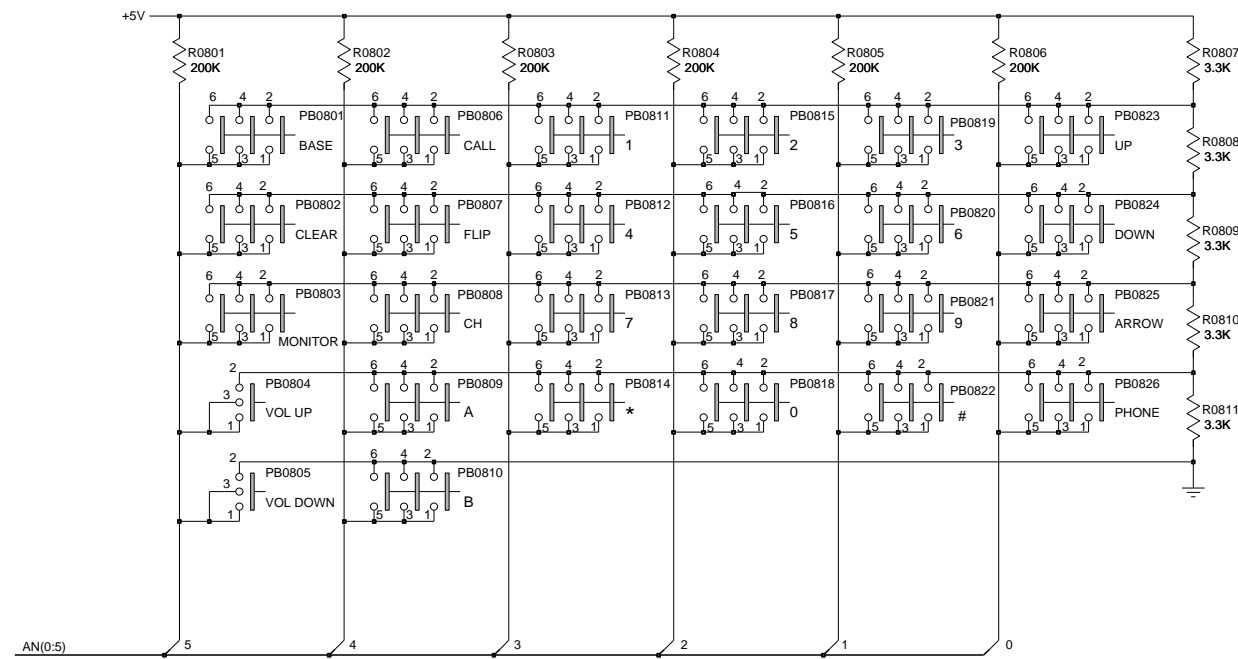

0102726B24
Controlhead T sheet 2
GEPD5586

Display/Keypad Radio Control Head Parts List

Circuit Ref	Motorola Part No.	Description
C0831	2113743E20	100nF 16V
C0841	2113743E20	100nF 16V
C0861	2113743E20	100nF 16V
C0891	2113743E20	100nF 16V
C0892	2113743E20	100nF 16V
C0893	2311049A45	TANT 10uF 10% 35V
C0894	2113743E07	22nF 16V
C0895	2311049A99	TANT 47uF 20% 10V
C0896	2113743E20	100nF 16V
C0897	2113741F17	470pF 50V
C0898	2311049A99	TANT 47uF 20% 10V
C0901	2113741F17	470pF 50V
C0902	2113741F17	470pF 50V
C0912	2311049A09	TANT 2.2uF 10% 20V
C0922	2113740F35	22pF 5% 50V NPO
C0924	2113740F39	33pF 5% 50V NPO
C0925	2113743E20	100nF 16V
C0926	2113743E20	100nF 16V
C0927	2113741F49	10nF 50V
C0928	2311049A42	TANT 3.3uF 10% 6V
C0930	2113743E20	100nF 16V
C0936	2113741F17	470pF 50V
C0938	2113741F17	470pF 50V
C0941-C0945	2113743E20	100nF 16V
C0951	2311049A09	TANT 2.2uF 10% 20V
C0953	2311049A09	TANT 2.2uF 10% 20V
C0954	2113741F49	10nF 50V
C0955	2311049A42	TANT 3.3uF 10% 6V
D0801-D0830	4805729G75	LED GREEN HP

Circuit Ref	Motorola Part No.	Description
D0851-D0876	4805729G75	LED GREEN HP
D0881-D0882	4805729G73	LED YEL HP
D0883	4805729G75	LED GREEN HP
D0884	4805729G74	LED RED HP
D0891	4813833C02	DUAL SOT MMBD6100
D0892	4813833C02	DUAL SOT MMBD6100
D0931	4813833C02	DUAL SOT MMBD6100
J0901	0902636Y01	CONNECTOR FLEX SIDE ENTRY
J0903	2805924V01	CONNECTOR MIC
Q0831	4813822A08	-
Q0832	4813824A10	NPN 40V .2A B=50-150
Q0851	4813822A08	-
Q0852	4813824A10	NPN 40V .2A B=50-150
Q0881-Q0883	4813824A10	NPN 40V .2A B=50-150
Q0891	4880048M01	NPN DIG 47k/47k
Q0931	4880048M01	NPN DIG 47k/47k
Q0932	4880048M01	NPN DIG 47k/47k
R0801-R0806	0662057B05	200k 1/16W
R0807-R0811	0662057A61	3k3 1/16W 5%
R0831	0662057A73	10k 1/16W 5%
R0832	0662057A85	33k 1/16W 5%
R0833-R0836	0662057A53	1k5 1/16W 5%
R0837	0662057A61	3k3 1/16W 5%
R0838	0662057A65	4k7 1/16W 5%
R0839	0662057A97	100k 1/16W
R0840	0662057A73	10k 1/16W 5%
R0841	0662057A73	10k 1/16W 5%
R0842	0680194M01	10 1W 5%
R0843	0680194M01	10 1W 5%

Circuit Ref	Motorola Part No.	Description
R0851	0662057A73	10k 1/16W 5%
R0852	0662057A85	33k 1/16W 5%
R0853-R0856	0662057A53	1k5 1/16W 5%
R0857	0662057A65	4k7 1/16W 5%
R0858	0662057A97	100k 1/16W
R0859	0662057A73	10k 1/16W 5%
R0860	0662057A73	10k 1/16W 5%
R0861	0680194M01	10 1W 5%
R0862	0680194M01	10 1W 5%
R0881	0660076A35	270 5 1/8
R0882	0660076A35	270 5 1/8
R0883	0662057A41	470 1/16W 5%
R0891	0662057A73	10k 1/16W 5%
R0892	0662057A97	100k 1/16W
R0893	0662057A01	10 1/16W 5%
R0894	0662057A01	10 1/16W 5%
R0896	0662057A57	2k2 1/16W 5%
R0897	0662057A65	4k7 1/16W 5%
R0901	0662057A09	22 1/16W 5%
R0902	0662057B47	0 1/16W
R0903	0662057A01	10 1/16W 5%
R0904	0662057A35	270 1/16W 5%
R0906	0662057A89	47k 1/16W 5%
R0908	0662057B47	0 1/16W
R0909	0662057A89	47k 1/16W 5%
R0912	0662057B47	0 1/16W
R0914	0662057A97	100k 1/16W
R0915	0662057B05	200k 1/16W
R0916	0662057A89	47k 1/16W 5%
R0917	0662057A97	100k 1/16W 5%
R0918	0680149M02	THERMISTOR 100K @25C
R0922	0662057B28	1.8M 1/16W 5%
R0923	0662057A89	47k 1/16W 5%

Circuit Ref	Motorola Part No.	Description
R0924	0662057A89	47k 1/16W 5%
R0925	0662057A73	10k 1/16W 5%
R0926	0662057A57	2k2 1/16W 5%
R0927	0662057A73	10k 1/16W 5%
R0928	0662057A25	100 1/16W 5%
R0929	0662057A89	47k 1/16W 5%
R0931-R0933	0662057A49	1k 1/16W 5%
R0934	0662057A25	100 1/16W 5%
R0936-R0938	0662057A65	4k7 1/16W 5%
R0946	0662057B22	1M 1/16W 5%
R0950	0662057A73	10k 1/16W 5%
R0951	0662057A85	33k 1/16W 5%
R0955	0662057B47	0 1/16W
R0956	0662057B47	0 1/16W
R0957	0662057B47	0 1/16W
R0958	0662057B18	680K 1/16W 5%
R0959	0662057B12	390k 1/16W 5%
R0960	0662057A89	47k 1/16W 5%
U0831	5113818A03	IC HIGH PERFORMANCE
U0891	5105469E65	IC VLTG REGLTR LP2951C
U0901	5102226J16	68HC711E20 64PQFP OTP
U0931	5105279V65	TC7S08F
VR0891	4813830A14	5.1V 5% 225mW
VR0901	4813830A15	5.6V 5% 225mW
VR0902	4813830A15	5.6V 5% 225mW
VR0903	4813830A27	14V 5% 225mW
VR0904	4813830A27	14V 5% 225mW
VR0931 - VR0934	4813830A15	5.6V 5% 225mW
Y0921	4880113R01	CRYSTAL 7.9488

Associated Schematics	
UHF PCB : 8486072B01_T1	Page
Controller	3.2-5
Controller_Audio	3.2-7
Controller_IO	3.2-9
Supply Voltage	3.2-11
Power Control	3.2-13
Power Amplifier	3.2-15
Synthesizer	3.2-17
Voltage Controlled Oscillator	3.2-19
RX-FE	3.2-21
RX-IF	3.2-23

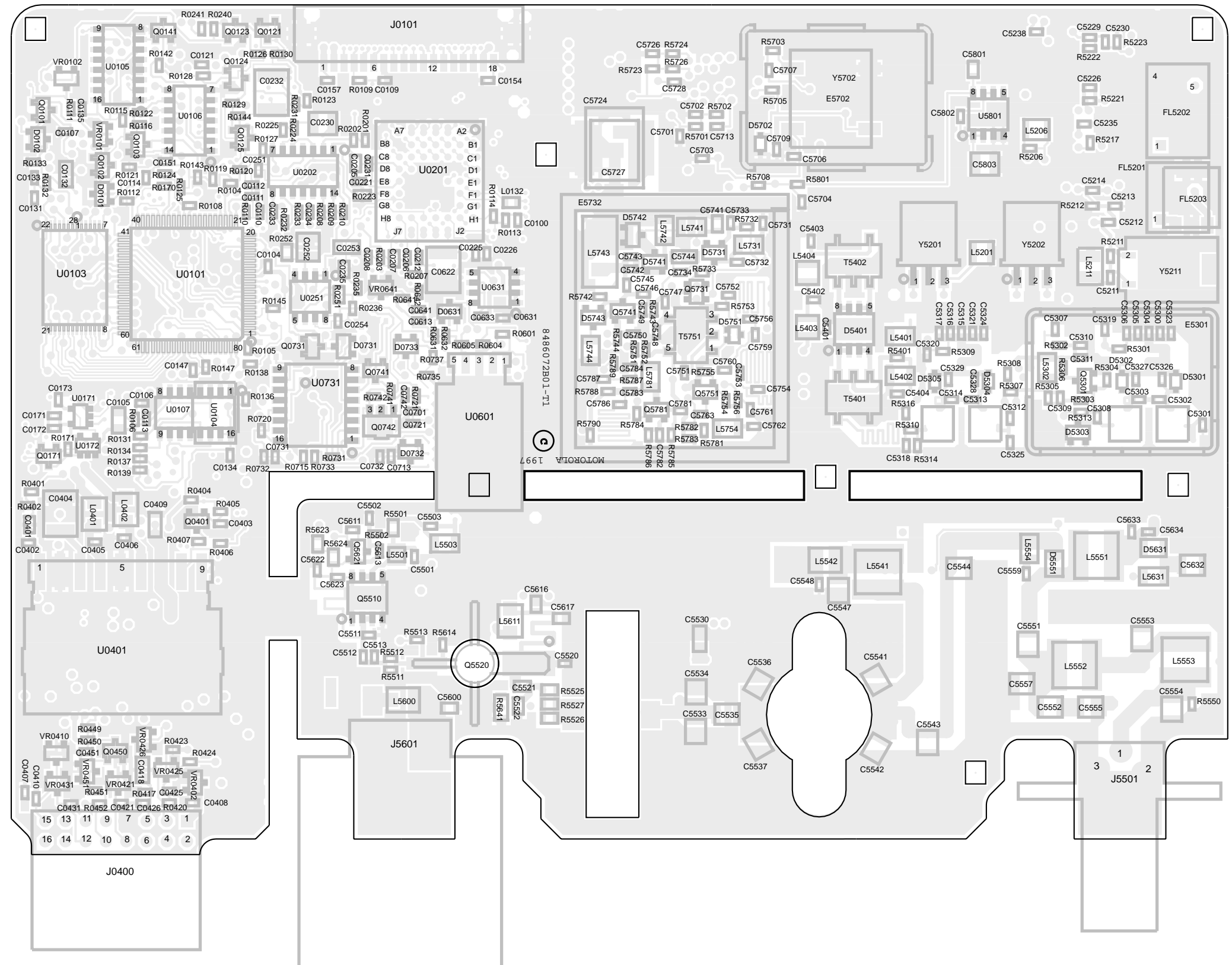

UHF (403-470MHz) Main Board Top Side
PCB No. 8486072B01_T1

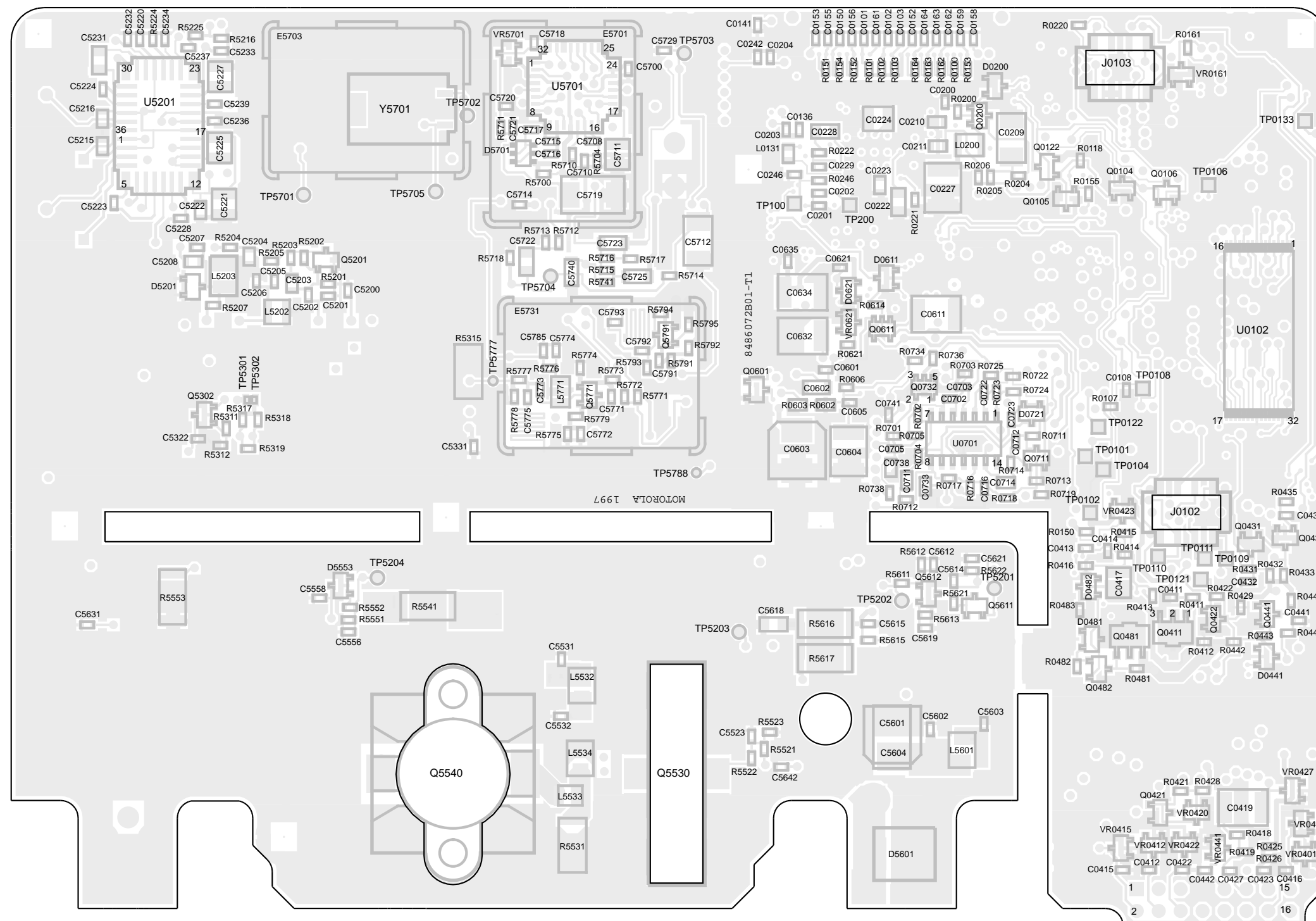

UHF (403-470MHz) Main Board Bottom Side
PCB No. 8486072B01_T1

Associated Schematics	
VHF PCB : 8486069B01_T1	Page
Controller	3.2-5
Controller_Audio	3.2-7
Controller_IO	3.2-9
Supply Voltage	3.2-11
Power Control	3.2-25
Power Amplifier	3.2-27
Synthesizer	3.2-29
Voltage Controlled Oscillator	3.2-31
RX-FE	3.2-33
RX-IF	3.2-35

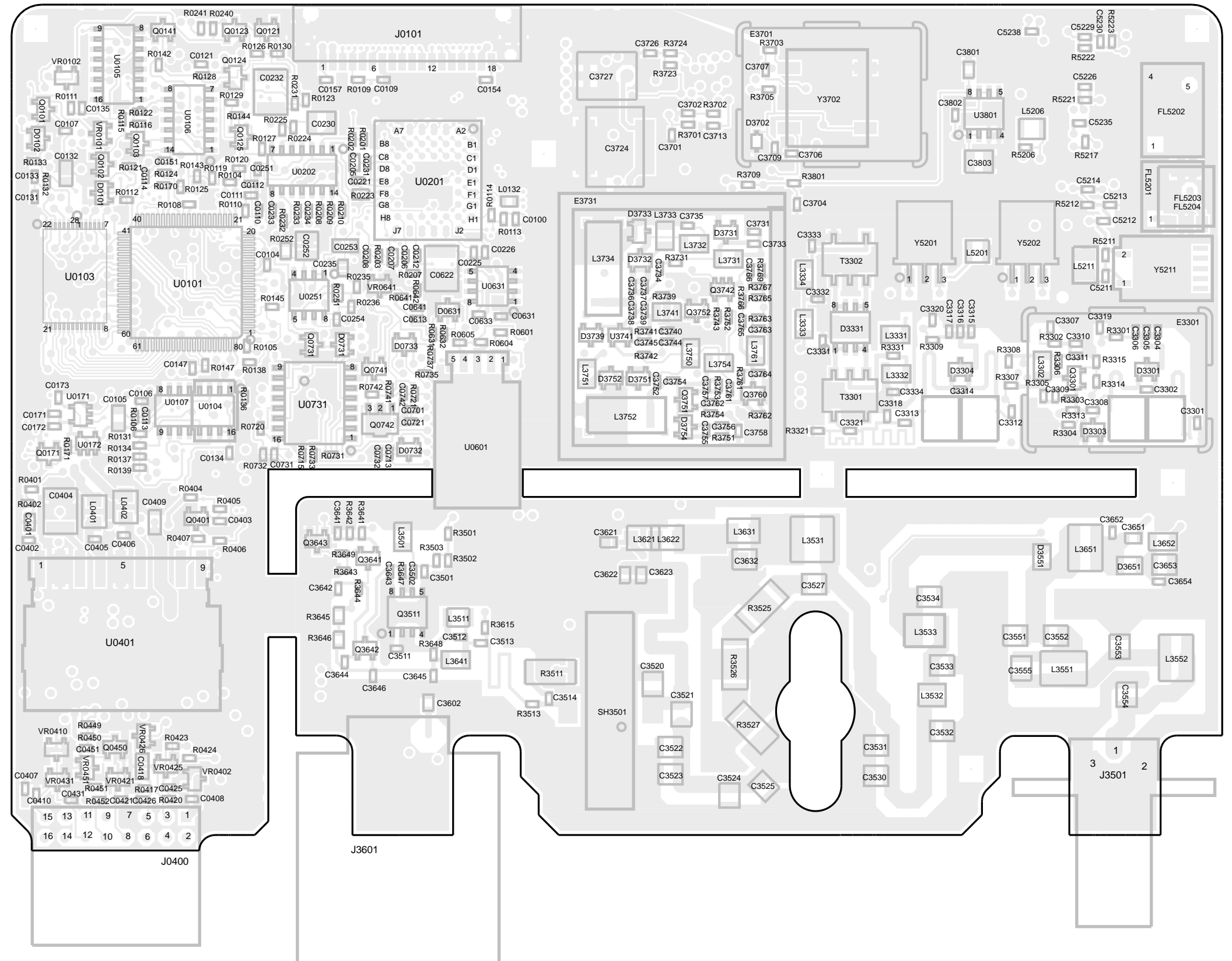

VHF (136-174MHz) Main Board Top Side
PCB No. 8486069B01_T1

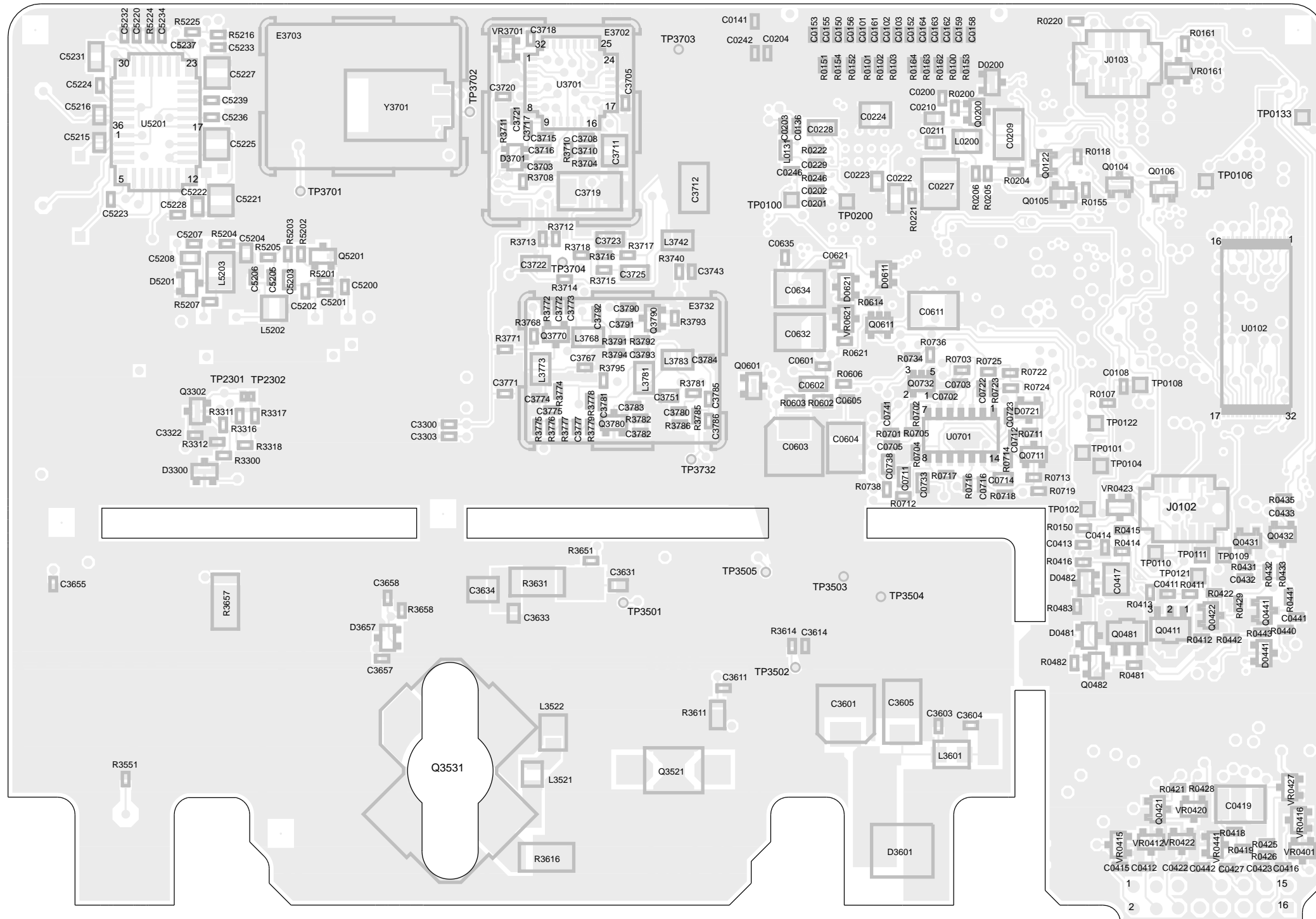

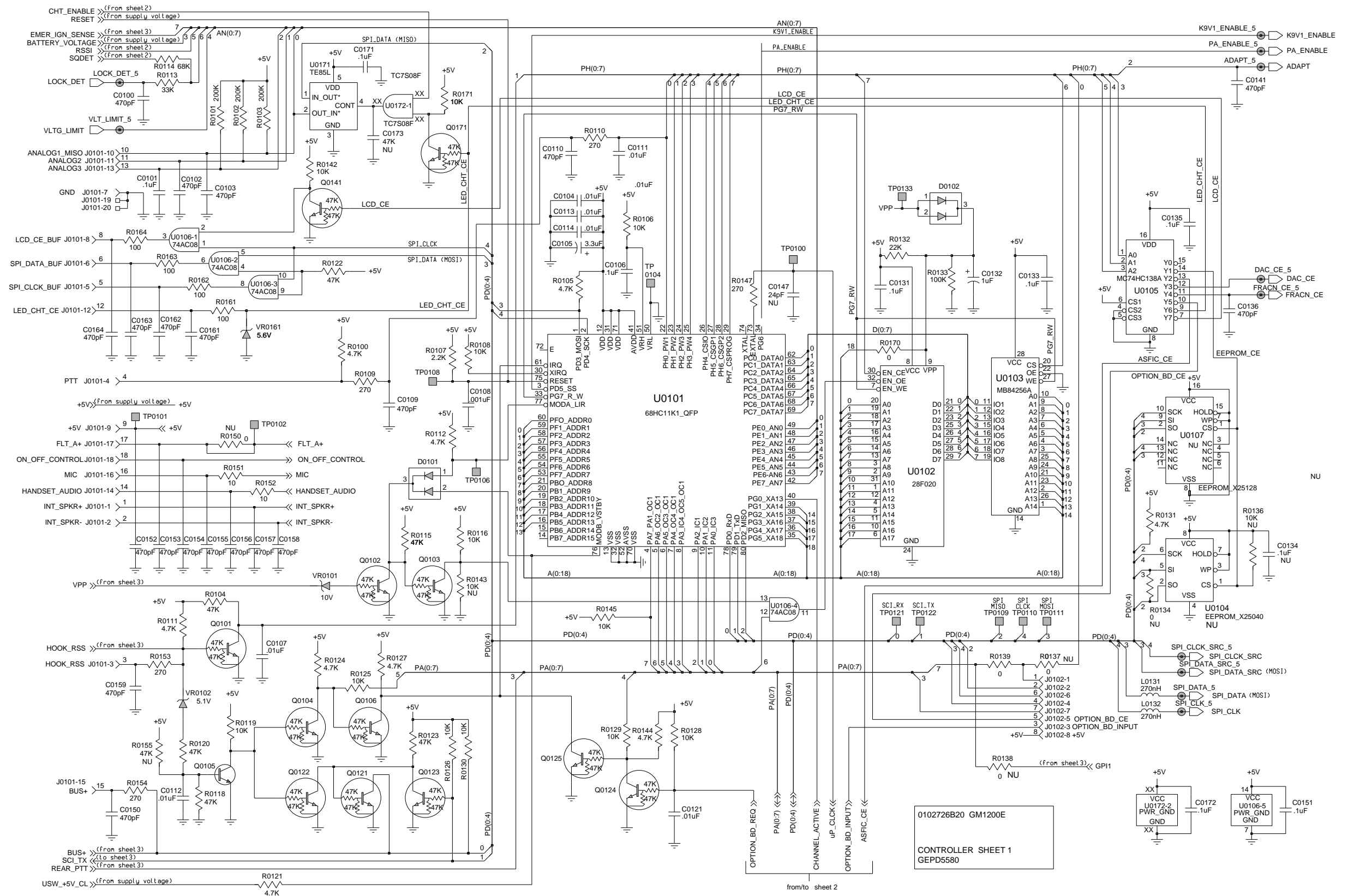

Controller Schematic Diagram
1 of 3

Controller Parts List

Circuit Ref	Motorola Part No.	Description
C0100	2113741F17	CAP CHIP 470pF 50V
C0101	2113743E20	CAP CHIP 100nF 16V
C0102	2113741F17	CAP CHIP 470pF 50V
C0103	2113741F17	CAP CHIP 470pF 50V
C0104	2113741F49	CAP CHIP 10nF 50V
C0105	2311049A42	TANT CP 3.3uF 10% 6V
C0106	2113743E20	CAP CHIP 100nF 16V
C0107	2113741F49	CAP CHIP 10nF 50V
C0108	2113741F25	CAP CHIP 1nF 50V
C0109	2113741F17	CAP CHIP 470pF 50V
C0110	2113741F17	CAP CHIP 470pF 50V
C0111	2113741F49	CAP CHIP 10nF 50V
C0112	2113741F49	CAP CHIP 10nF 50V
C0113	2113741F49	CAP CHIP 10nF 50V
C0114	2113741F49	CAP CHIP 10nF 50V
C0121	2113741F49	CAP CHIP 10nF 50V
C0131	2113743E20	CAP CHIP 100nF 16V
C0133	2113743E20	CAP CHIP 100nF 16V
C0134	2113743E20	CAP CHIP 100nF 16V
C0135	2113743E20	CAP CHIP 100nF 16V
C0136	2113741F17	CAP CHIP 470pF 50V
C0141	2113741F17	CAP CHIP 470pF 50V
C0147	2113740F36	CAP CHIP 24pF 50V
C0150	2113741F17	CAP CHIP 470pF 50V
C0151	2113743E20	CAP CHIP 100nF 16V
C0152	2113741F17	CAP CHIP 470pF 50V
C0153	2113741F17	CAP CHIP 470pF 50V
C0154	2113741F17	CAP CHIP 470pF 50V
C0155	2113741F17	CAP CHIP 470pF 50V
C0156	2113741F17	CAP CHIP 470pF 50V
C0157	2113741F17	CAP CHIP 470pF 50V

Circuit Ref	Motorola Part No.	Description
C0158	2113741F17	CAP CHIP 470pF 50V
C0159	2113741F17	CAP CHIP 470pF 50V
C0161	2113741F17	CAP CHIP 470pF 50V
C0162	2113741F17	CAP CHIP 470pF 50V
C0163	2113741F17	CAP CHIP 470pF 50V
C0164	2113741F17	CAP CHIP 470pF 50V
C0171	2113743E20	CAP CHIP 100nF 16V
C0172	2113743E20	CAP CHIP 100nF 16V
C0200	2113743E20	CAP CHIP 100nF 16V
C0201	2113741F17	CAP CHIP 470pF 50V
C0202	2113741F17	CAP CHIP 470pF 50V
C0203	2113741F17	CAP CHIP 470pF 50V
C0204	2113741F17	CAP CHIP 470pF 50V
C0205	2113743F08	CAP CHIP 220nF 5% 50V
C0206	2113743E20	CAP CHIP 100nF 16V
C0207	2113743F08	CAP CHIP 220nF 5% 50V
C0208	2113741F13	CAP CHIP 330pF 50V
C0209	2311049J26	TANT CP 10uF 20% 16V
C0210	2113741M53	CAP CHIP 22nF 50V
C0211	2113743A19	CAP CHIP 100nF 16V
C0212	2113743E20	CAP CHIP 100nF 16V
C0221	2113743E20	CAP CHIP 100nF 16V
C0222	2311049A07	CAP TANT CP 1uF 10% 16V
C0223	2113741A57	CAP CHIP 33nF 50V
C0224	2311049J11	TANT CP 4.7uF 10% 16V
C0225	2113741F49	CAP CHIP 10nF 50V
C0226	2113743E20	CAP CHIP 100nF 16V
C0227	2311049A99	TANT CP 47uF 20% 10V
C0228	2311049A01	TANT CP 100nF 10% 35V
C0229	2113741F49	CAP CHIP 10nF 50V
C0230	2311049J23	CAP TANT CP 10uF 10% 6V
C0231	2113741F49	CAP CHIP 10nF 50V
C0233	2113740F39	CAP CHIP 33pF 5% 50V

Circuit Ref	Motorola Part No.	Description
C0234	2113743E20	CAP CHIP 100nF 16V
C0235	2113743A19	CAP CHIP 100nF 16V
C0242	2113741F17	CAP CHIP 470pF 50V
C0246	2113740F36	CAP CHIP 24pF 5% 50V
C0251	2113743E20	CAP CHIP 100nF 16V
C0252	2311049J23	CAP TANT CP 10uF 10% 6V
C0253	2311049A07	CAP TANT CP 1uF 10% 16V
C0254	2113743E20	CAP CHIP 100nF 16V
C0401	2113743A19	CAP CHIP 100nF 16V
C0402	2113741F37	CAP CHIP 3.3nF 50V
C0404	2311049A99	TANT CP 47uF 20% 10V
C0405	2113741F25	CAP CHIP 1nF 50V
C0406	2113741F25	CAP CHIP 1nF 50V
C0407	2113741F49	CAP CHIP 10nF 50V
C0408	2113741F49	CAP CHIP 10nF 50V
C0409	2109720D14	CER LOW DIST 100nF
C0410	2113741F17	CAP CHIP 470pF 50V
C0412	2113741F17	CAP CHIP 470pF 50V
C0415	2113741F17	CAP CHIP 470pF 50V
C0416	2113741F17	CAP CHIP 470pF 50V
C0418	2311049A05	TANT CP 470nF 10% 25V
C0419	2311049A99	TANT CP 47uF 20% 10V
C0421	2113741F17	CAP CHIP 470pF 50V
C0422	2113741F17	CAP CHIP 470pF 50V
C0423	2113741F17	CAP CHIP 470pF 50V
C0425	2113741F17	CAP CHIP 470pF 50V
C0426	2113741F17	CAP CHIP 470pF 50V
C0427	2113741F17	CAP CHIP 470pF 50V
C0431	2113741F17	CAP CHIP 470pF 50V
C0433	2113741F49	CAP CHIP 10nF 50V
C0441	2113741F17	CAP CHIP 470pF 50V
C0442	2113741F17	CAP CHIP 470pF 50V
C0451	2113741F17	CAP CHIP 470pF 50V

Circuit Ref	Motorola Part No.	Description
D0101	4813833C02	DUAL SOT MMBD6100
D0102	4813833C02	DUAL SOT MMBD6100
D0200	4813833C02	DUAL SOT MMBD6100
D0441	4813833C02	DUAL SOT MMBD6100
D0482	4813833C02	DUAL SOT MMBD6100
J0101	0902636Y01	CONNECTOR FLEX SIDE ENTRY
J0102	0904424J06	CONNECTOR 8 POS SMD T&R
J0103	0904424J06	CONNECTOR 8 POS SMD T&R
J0400	2804503J01	CONNECTOR ACCY 16 PIN
L0131	2462587Q40	COIL CHIP 270nH
L0132	2462587Q40	COIL CHIP 270nH
L0200	2462587K26	CHIP IND 33000 NH
L0401	2484657R01	Ferrite Bead
L0402	2484657R01	Ferrite Bead
Q0101	4880048M01	TSTR NPN DIG 47k/47k
Q0102	4880048M01	TSTR NPN DIG 47k/47k
Q0103	4880048M01	TSTR NPN DIG 47k/47k
Q0104	4880048M01	TSTR NPN DIG 47k/47k
Q0105	4813824A10	TSTR NPN 40V .2A B=50-150
Q0106	4880048M01	TSTR NPN DIG 47k/47k
Q0121	4880048M01	TSTR NPN DIG 47k/47k
Q0122	4880048M01	TSTR NPN DIG 47k/47k
Q0123	4880048M01	TSTR NPN DIG 47k/47k
Q0124	4880048M01	TSTR NPN DIG 47k/47k
Q0125	4880048M01	TSTR NPN DIG 47k/47k
Q0141	4880048M01	TSTR NPN DIG 47k/47k
Q0171	4880048M01	TSTR NPN DIG 47k/47k
Q0200	4813824A10	TSTR NPN 40V .2A B=50-150
Q0401	4813824A10	TSTR NPN 40V .2A B=50-150

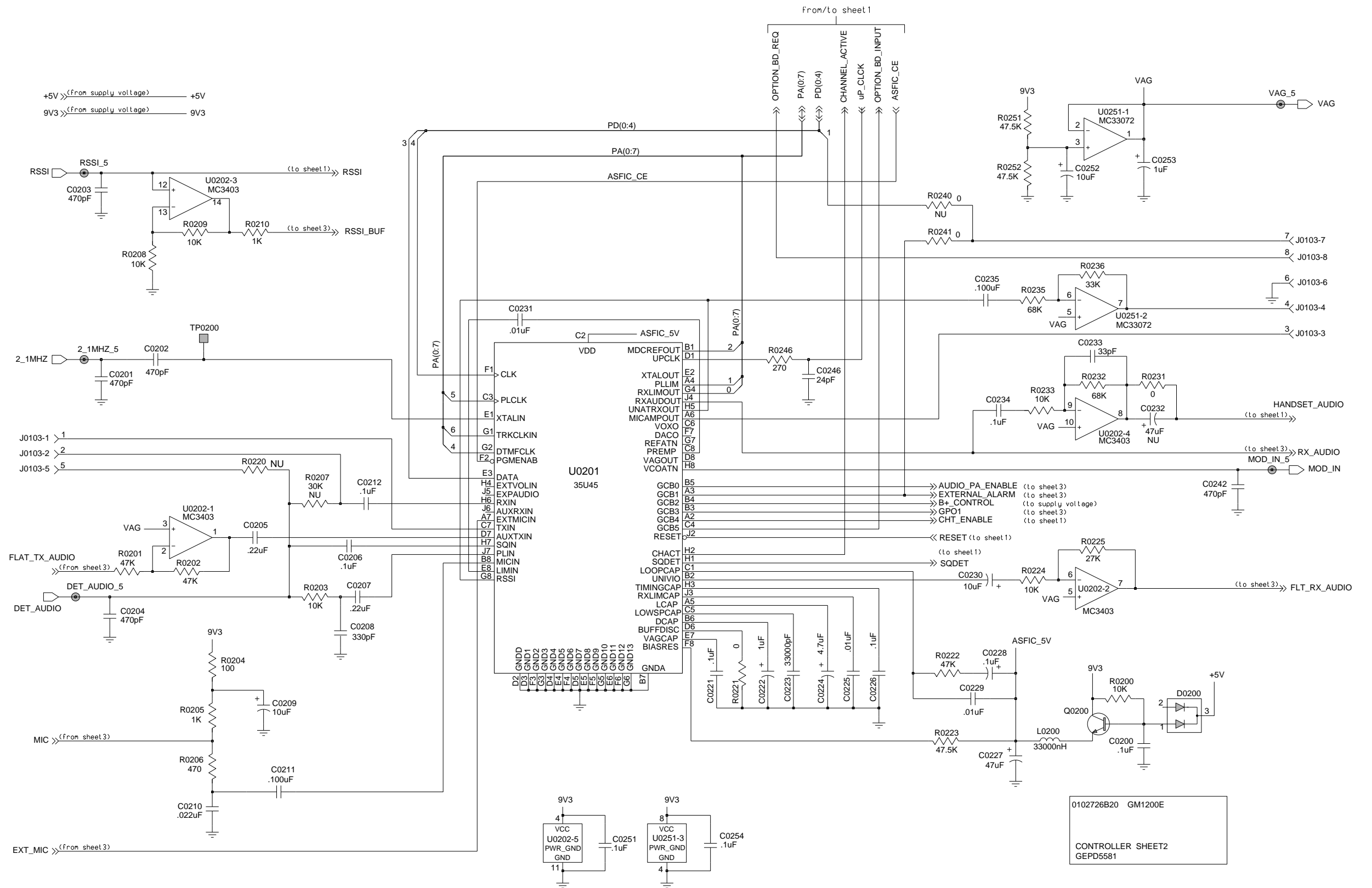

Controller_Audio Schematic Diagram
2 of 3

Controller_Audio Schematic Diagram

Circuit Ref	Motorola Part No.	Description
Q0411	4880052M01	TSTR NPN DRLNGTN MXTA
Q0432	4813824A10	TSTR NPN 40V .2A B=50-150
Q0441	4880048M01	TSTR NPN DIG 47k/47k
Q0450	4880048M01	TSTR NPN DIG 47k/47k
Q0481	4805128M27	TSTR PNP SOT89 BSR33 LH
Q0482	4813824A10	TSTR NPN 40V .2A B=50-150
R0100	0662057A65	4k7 1/16W 5%
R0101	0662057B05	200k 1/16W
R0102	0662057B05	200k 1/16W
R0103	0662057B05	200k 1/16W
R0104	0662057A89	47k 1/16W 5%
R0105	0662057A65	4k7 1/16W 5%
R0106	0662057A73	10k 1/16W 5%
R0107	0662057A57	2k2 1/16W 5%
R0108	0662057A73	10k 1/16W 5%
R0109	0662057A35	270 1/16W 5%
R0110	0662057A35	270 1/16W 5%
R0111	0662057A65	4k7 1/16W 5%
R0112	0662057A65	4k7 1/16W 5%
R0113	0662057A85	33k 1/16W 5%
R0114	0662057A93	68k 1/16W 5%
R0115	0662057A89	47k 1/16W 5%
R0116	0662057A73	10k 1/16W 5%
R0118	0662057A89	47k 1/16W 5%
R0119	0662057A73	10k 1/16W 5%
R0120	0662057A89	47k 1/16W 5%
R0121	0662057A65	4k7 1/16W 5%
R0122	0662057A89	47k 1/16W 5%
R0123	0662057A89	47k 1/16W 5%
R0124	0662057A65	4k7 1/16W 5%
R0125	0662057A73	10k 1/16W 5%

Circuit Ref	Motorola Part No.	Description
R0126	0662057A73	10k 1/16W 5%
R0127	0662057A65	4k7 1/16W 5%
R0128	0662057A73	10k 1/16W 5%
R0129	0662057A73	10k 1/16W 5%
R0130	0662057A73	10k 1/16W 5%
R0131	0662057A65	4k7 1/16W 5%
R0139	0662057B47	0 1/16W
R0142	0662057A73	10k 1/16W 5%
R0144	0662057A65	4k7 1/16W 5%
R0145	0662057A73	10k 1/16W 5%
R0147	0662057A35	270 1/16W 5%
R0151	0662057A01	10 1/16W 5%
R0152	0662057A01	10 1/16W 5%
R0153	0662057A35	270 1/16W 5%
R0154	0662057A35	270 1/16W 5%
R0161	0662057A25	100 1/16W 5%
R0162	0662057A25	100 1/16W 5%
R0163	0662057A25	100 1/16W 5%
R0164	0662057A25	100 1/16W 5%
R0170	0662057B47	0 1/16W
R0171	0662057A73	10k 1/16W 5%
R0200	0662057A73	10k 1/16W 5%
R0201	0662057A89	47k 1/16W 5%
R0202	0662057A89	47k 1/16W 5%
R0203	0662057A73	10k 1/16W 5%
R0204	0662057A25	100 1/16W 5%
R0205	0662057A49	1k 1/16W 5%
R0206	0662057A41	470 1/16W 5%
R0208	0662057A73	10k 1/16W 5%
R0209	0662057A73	10k 1/16W 5%
R0210	0662057A49	1k 1/16W 5%
R0221	0662057B47	0 1/16W
R0222	0662057A89	47k 1/16W 5%

Circuit Ref	Motorola Part No.	Description
R0223	0662057R92	47.5k .1W 1%
R0224	0662057A73	10k 1/16W 5%
R0225	0662057A83	27k 1/16W 5%
R0231	0662057B47	0 1/16W
R0232	0662057A93	68k 1/16W 5%
R0233	0662057A73	10k 1/16W 5%
R0235	0662057A93	68k 1/16W 5%
R0236	0662057A85	33k 1/16W 5%
R0241	0662057B47	0 1/16W
R0246	0662057A35	270 1/16W 5%
R0251	0662057R92	47.5k .1W 1%
R0252	0662057R92	47.5k .1W 1%
R0401	0662057A65	4k7 1/16W 5%
R0402	0662057A49	1k 1/16W 5%
R0404	0662057A73	10k 1/16W 5%
R0405	0662057A73	10k 1/16W 5%
R0406	0662057A81	22k 1/16W 5%
R0407	0662057A77	15k 1/16W 5%
R0411	0662057A73	10k 1/16W 5%
R0412	0662057A65	4k7 1/16W 5%
R0413	0662057B47	0 1/16W
R0417	0662057A97	100k 1/16W
R0418	0662057A18	51 1/16W 5%
R0419	0662057A97	100k 1/16W
R0420	0662057A35	270 1/16W 5%
R0421	0662057A43	560 1/16W 5%
R0422	0662057A35	270 1/16W 5%
R0423	0662057A65	4k7 1/16W 5%
R0424	0662057A35	270 1/16W 5%
R0425	0662057A09	22 1/16W
R0433	0662057A65	4k7 1/16W 5%
R0435	0662057A73	10k 1/16W 5%
R0440	0662057A93	68k 1/16W 5%

Circuit Ref	Motorola Part No.	Description
R0441	0662057A65	4k7 1/16W 5%
R0442	0662057A61	3k3 1/16W 5%
R0443	0662057A89	47k 1/16W 5%
R0449	0662057A85	33k 1/16W 5%
R0450	0662057A65	4k7 1/16W 5%
R0451	0662057A65	4k7 1/16W 5%
R0481	0662057A49	1k 1/16W 5%
R0482	0662057A43	560 1/16W 5%
R0483	0662057A53	1k5 1/16W 5%
U0101	5113802A48	68HC11K1_QFP
U0102	5186137B01	49F040
U0103	5105662U54	HYBRID 32KX8 SRAM TEST
U0105	5113805A30	IC 10F8 DCDR/REMUX 74HC138
U0106	5113805A06	74AC08 4 AND GATES
U0107	5186048B01	EEPROM_X25128
U0171	5105750U28	SNGL ANALOG SWITCH SMD
U0172	5105279V65	TC7S08F
U0201	5105835U45	ASFIC
U0202	5183222M49	IC QUAD OPAMP __3403_
U0251	5113818A03	IC HIGH PERFORMANCE SI
U0401	5109699X01	AUDIO PA TDA1915C
VR0101	4813830A23	10V 5% 20mA 350mW
VR0102	4813830A14	5.1V 5% 225mW
VR0161	4813830A15	5.6V 5% 225mW
VR0410	4813830A27	14V 5% 225MW MMB
VR0412	4813830A40	SOC23 AUTO SDN
VR0415	4813830A27	14V 5% 225MW
VR0416	4813830A27	14V 5% 225MW
VR0420	4813830A15	5.6V 5% 225mW
VR0423	4813830A15	5.6V 5% 225mW
VR0425	4813830A15	5.6V 5% 225mW

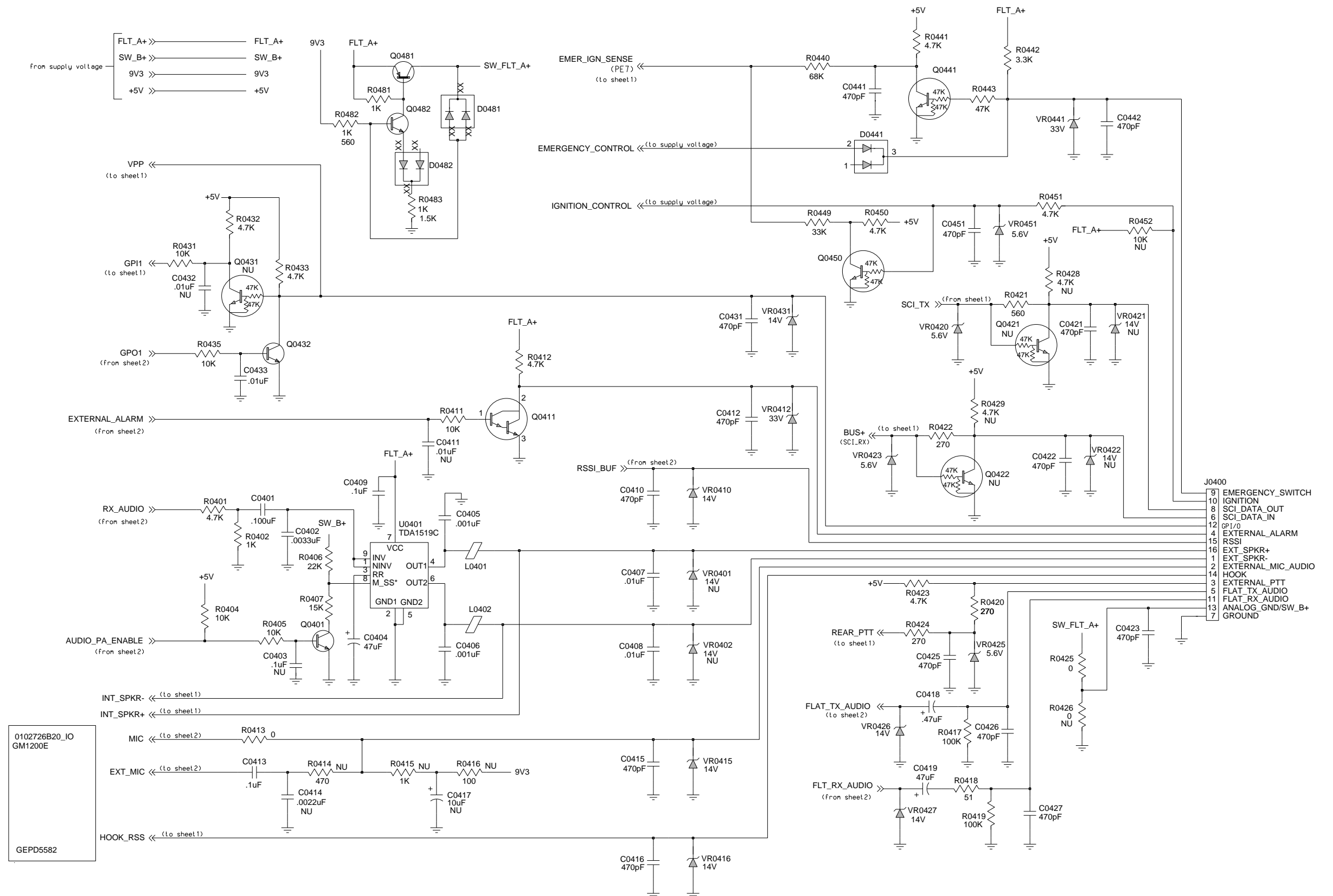

Controller_IO Schematic Diagram
3 of 3

Controller_IO Schematic Diagram

Circuit Ref	Motorola Part No.	Description
VR0426	4813830A27	14V 5% 225MW
VR0427	4813830A27	14V 5% 225MW
VR0431	4813830A27	14V 5% 225MW
VR0441	4813830A40	SOC23 AUTO SDN
VR0451	4813830A15	5.6V 5% 225mW

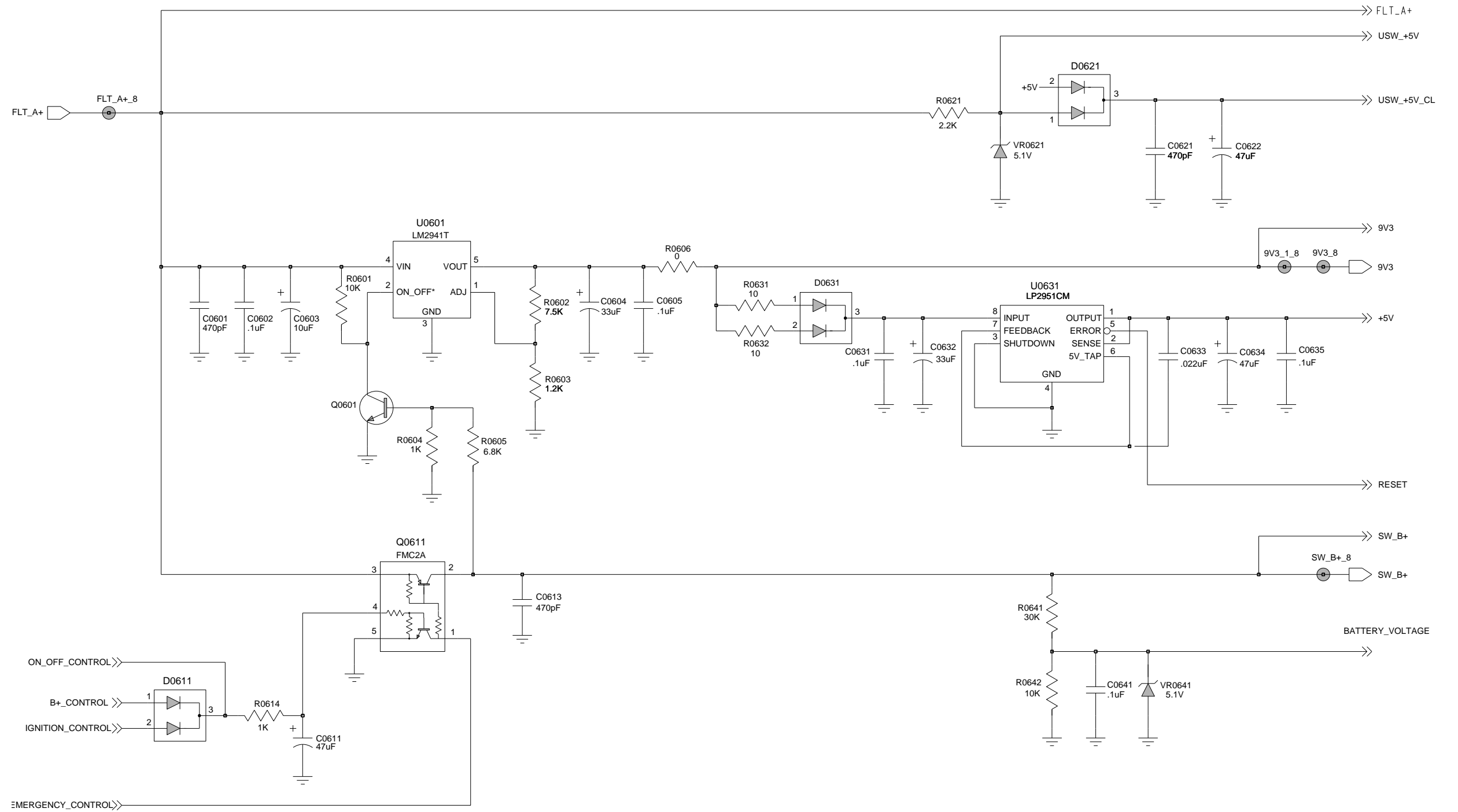

0102726B19
SUPPLY VLTG

GEPD5577

Supply Voltage
Parts List

Circuit Ref	Motorola Part No.	Description
C0601	2113741F17	470pF 50V
C0602	2113741B69	100nF 50V
C0603	2380090M24	LYT 10uF 50V 20%
C0604	2311049A97	TANT CHIP 33 UF 16
C0605	2113743E20	100nF 16V
C0611	2311049A97	TANT CP 33uF 20% 10V
C0613	2113741F17	470pF 50V
C0621	2113741F17	470pF 50V
C0622	2311049A99	TANT CP 47uF 20% 10V
C0631	2113743E20	100nF 16V
C0632	2311049A97	CAP TANT CHIP 33 UF 16
C0633	2113743E07	22nF 16V
C0634	2311049A99	TANT CP 47uF 20% 10V
C0635	2113743E20	100nF 16V
C0641	2113743E20	100nF 16V
D0611	4813833C02	DUAL SOT MMBD6100
D0621	4813833C02	DUAL SOT MMBD6100
D0631	4813833C02	DUAL SOT MMBD6100
Q0601	4813824A10	NPN 40V .2A B=50-150
Q0611	4805921T02	DUAL ROHM FMC2 RH
R0601	0662057A73	10k 1/16W 5%
R0602	0660076E70	FILM 7500 1 1
R0603	0660076E51	FILM 1200 1 1
R0604	0662057A49	1k 1/16W 5%
R0605	0662057A69	6k8 1/16W 5%
R0606	0662057B47	0 1/16W
R0614	0662057A53	1k 1/16W 5%
R0621	0662057A81	22 1/16W 5%
R0631	0662057A01	10 1/16W 5%
R0632	0662057A01	10 1/16W 5%
R0641	0662057A84	30k 1/16W 5%

Circuit Ref	Motorola Part No.	Description
R0642	0662057A73	10k 1/16W 5%
U0601	5105625U25	IC 9.3V REG 2941
U0631	5105469E65	IC VLTG REGLTR LP2951C
VR0621	4813830A14	5.1V 5% 225mW
VR0641	4813830A14	5.1V 5% 225mW

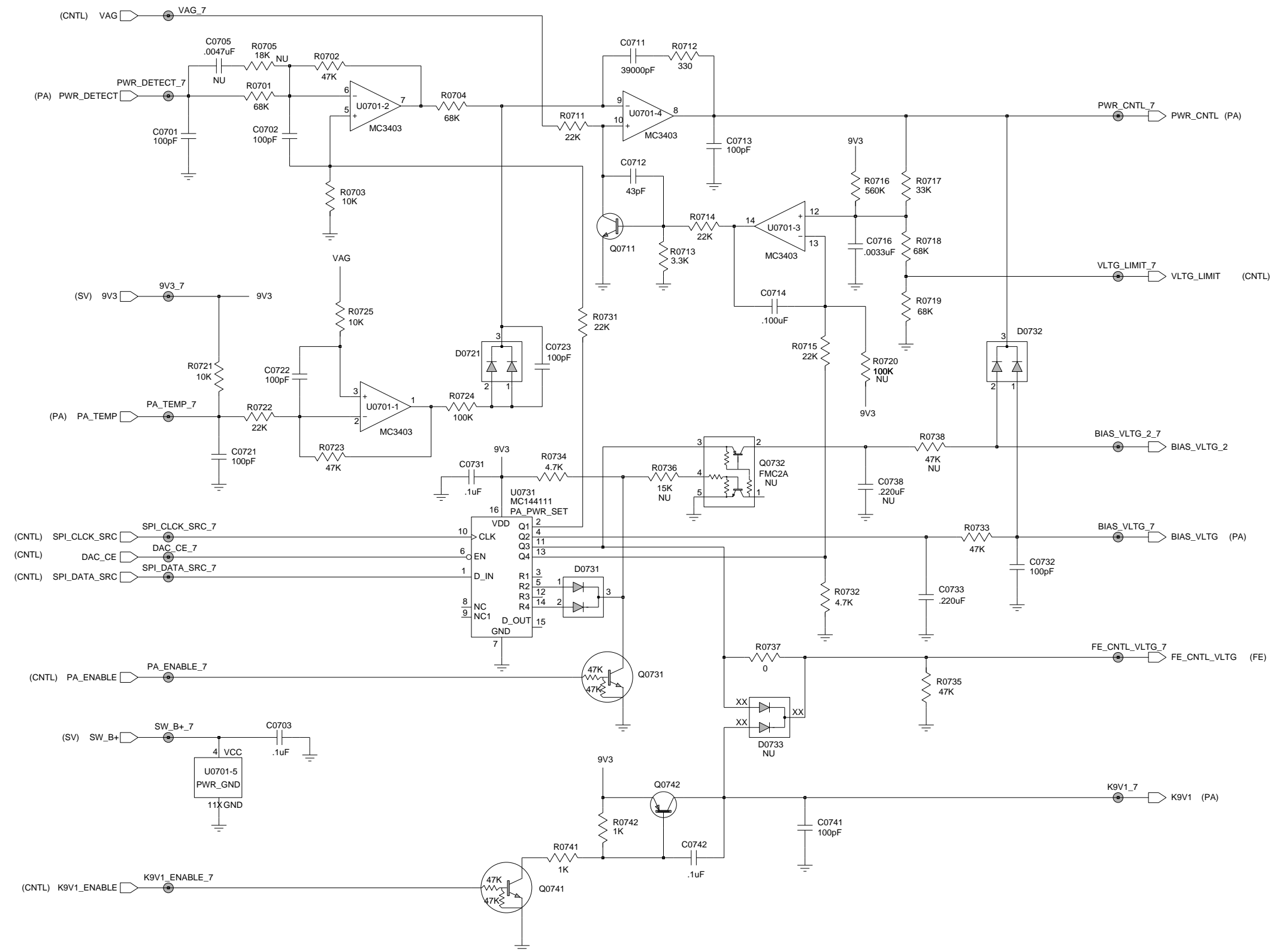

0102726B22 UHF PWR CNTL
GEPD 5579

UHF (403-470MHz) Power Control Schematic Diagram

**Power Control
Parts List**

Circuit Ref	Motorola Part No.	Description
C0701	2113740F51	100pF 5% 50V
C0702	2113740F51	100pF 5% 50V
C0703	2113743E20	100nF 16V
C0711	2113741A59	39000pF
C0712	2113740F42	43pF 5% 50V
C0713	2113740F51	100pF 5% 50V
C0714	2113743A19	100nF 16V
C0716	2113741F37	3.3nF 50V
C0721	2113740F51	100pF 5% 50V
C0722	2113740F51	100pF 5% 50V
C0723	2113740F51	100pF 5% 50V
C0731	2113743E20	100nF 16V
C0732	2113740F51	100pF 5% 50V
C0733	2113743A23	220nF 16V
C0741	2113740F51	100pF 5% 50V
C0742	2113743E20	100nF 16V
D0721	4813833C02	DUAL SOT MMBD6100
D0731	4813833C02	DUAL SOT MMBD6100
D0732	4813833C02	DUAL SOT MMBD6100
Q0711	4813824A10	NPN 40V .2A B=50-150
Q0731	4880048M01	NPN DIG 47k/47k
Q0741	4880048M01	NPN DIG 47k/47kx
Q0742	4805128M27	PNP SOT89 BSR33
R0701	0662057A93	68k 1/16W 5%
R0702	0662057A89	47k 1/16W 5%
R0703	0662057A73	10k 1/16W 5%
R0704	0662057A93	68k 1/16W 5%
R0711	0662057A81	22k 1/16W 5%
R0712	0662057A37	330 1/16W 5%
R0713	0662057A61	3k3 1/16W 5%
R0714	0662057A81	22k 1/16W 5%

Circuit Ref	Motorola Part No.	Description
R0715	0662057A81	22k 1/16W 5%
R0716	0662057B16	560k 1/16W 5%
R0717	0662057A85	33k 1/16W 5%
R0718	0662057A93	68k 1/16W 5%
R0719	0662057A93	68k 1/16W 5%
R0721	0662057A73	10k 1/16W 5%
R0722	0662057A81	22k 1/16W 5%
R0723	0662057A89	47k 1/16W 5%
R0724	0662057A97	100k 1/16W
R0725	0662057A73	10k 1/16W 5%
R0731	0662057A81	22k 1/16W 5%
R0732	0662057A65	4k7 1/16W 5%
R0733	0662057A89	47k 1/16W 5%
R0734	0662057A65	4k7 1/16W 5%
R0735	0662057A89	47k 1/16W 5%
R0737	0662057B47	0 1/16W
R0741	0662057A49	1k 1/16W 5%
R0742	0662057A49	1k 1/16W 5%
U0701	5183222M49	IC QUAD OPAMP __3403__
U0731	5113811G02	IC D/A CONV & BIT 4 CHAN W/SPI

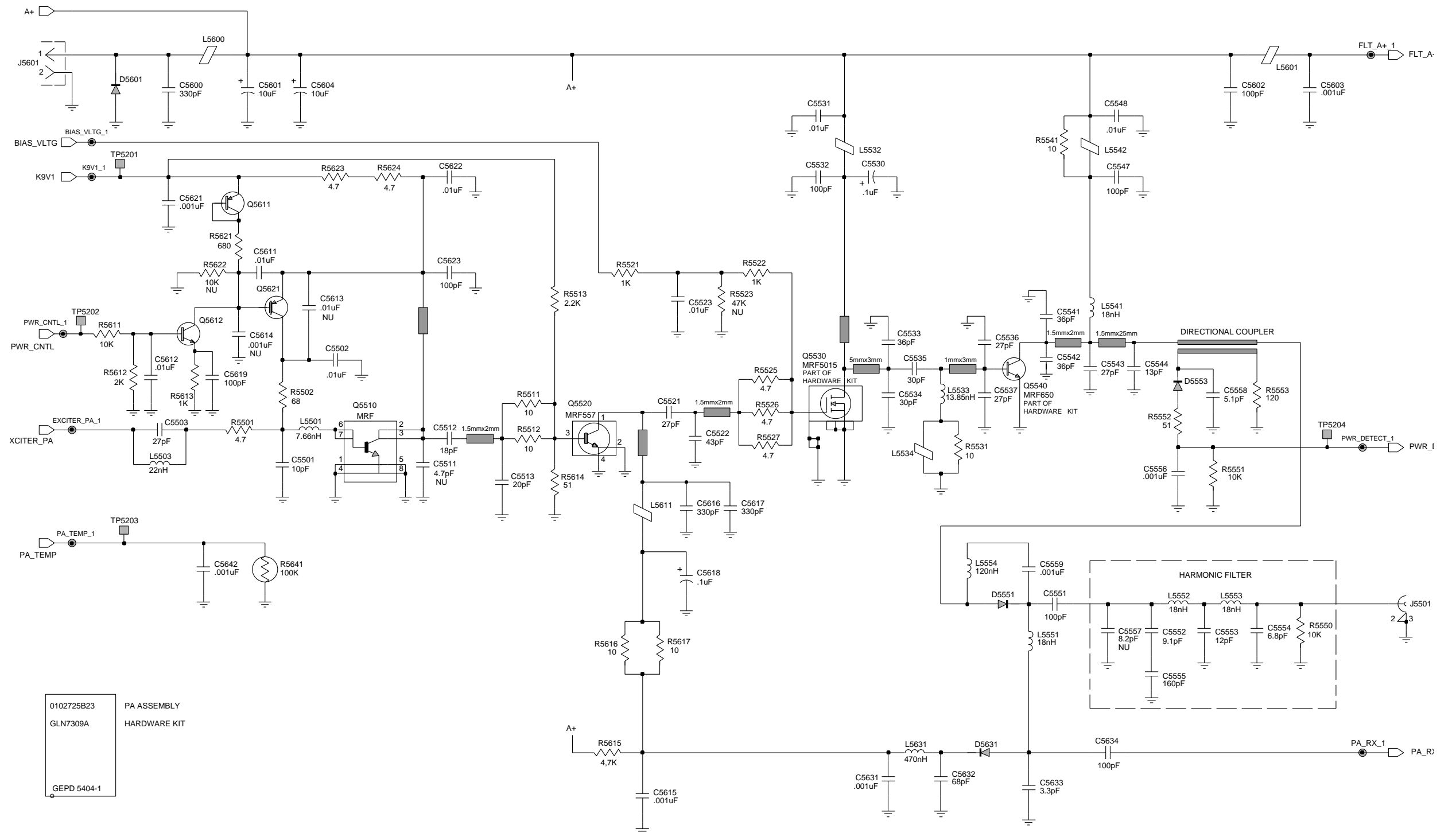

UHF (403-470MHz) Power Amplifier 5-25W Schematic Diagram

**Power Amplifier 5-25W
Parts List**

Circuit Ref	Motorola Part No.	Description
C5501	2113740F27	10pF 5% 50V
C5502	2113741F49	10nF 50V
C5503	2113740F37	27pF 5% 50V
C5512	2113740F33	18pF 5% 50V
C5513	2113740F34	20pF 5% 50V
C5521	2113740A39	27pF 5% 50V
C5522	2113740A44	43pF 5% 50V
C5523	2113741F49	10nF 50V
C5530	2311049A01	TANT CP 100nF 10% 35V
C5531	2113741F49	10nF 50V
C5532	2113740F51	100pF 5% 50V
C5533	2111078B31	HQ 36pF 5%
C5534	2111078B27	HQ 30pF 5%
C5535	2111078B27	HQ 30pF 5%
C5536	2111078B25	HQ 27pF 5%
C5537	2111078B25	HQ 27pF 5%
C5541	2111078B31	HQ 36pF 5%
C5542	2111078B31	HQ 36pF 5%
C5543	2111078B25	HQ 27pF 5%
C5544	2111078B16	HQ 13pF 5%
C5547	2111078B42	HQ 100pF 5%
C5548	2113741F49	10nF 50V
C5551	2111078B42	HQ 100pF
C5552	2111078B12	HQ 9.1pF 5%
C5553	2111078B15	HQ 12pF 5%
C5554	2111078B09	HQ 6.8pF 5%
C5555	2111078B48	HQ 160pF 5%
C5556	2113741F25	1nF 50V
C5558	2113740F20	5.1pF 5% 50V
C5559	2113741F25	1nF 50V
C5600	2113740A67	330pF 5% 50V

Circuit Ref	Motorola Part No.	Description
C5602	2113740F51	100pF 5% 50V
C5603	2113741F25	1nF 50V
C5604	2311049A45	TANT CP 10uF 10% 35V
C5611	2113741F49	10nF 50V
C5612	2113741F49	10nF 50V
C5615	2113741F25	1nF 50V
C5616	2113740A67	330pF 5% 50V
C5617	2113740A67	330pF 5% 50V
C5618	2311049A01	TANT CP 100nF 10% 35V
C5619	2113740F51	100pF 5% 50V
C5621	2113741F25	1nF 50V
C5622	2113741F49	10nF 50V
C5623	2113740F51	100pF 5% 50V
C5631	2113741F25	1nF 50V X7R
C5632	2111078B38	HQ 68pF 5%
C5633	2113740F15	3.3pF 5% 50V
C5634	2113740F51	100pF 5% 50V
C5642	2113741F25	1nF 50V
D5551	4802482J02	DIODE PIN MA/COM
D5553	4880236E05	DIODE CHIP SCHOTTKY
D5601	4813832B35	DIODE TRANSORB
D5631	4802482J02	DIODE PIN MA/COM
L5501	2460591A11	SQUARE COIL 7.66nH 3T
L5503	2462587T38	COIL CHIP 22nH 5%
L5532	2484657R01	Ferrite Bead
L5533	2460591C23	SQUARE COIL 16nH 3T
L5534	2484657R01	Ferrite Bead
L5541	2460591X01	COIL SQUARE
L5542	2484657R01	Ferrite Bead
L5551	2460591X01	COIL SQUARE
L5552	2460591X01	COIL SQUARE
L5553	2460591X01	COIL SQUARE
L5554	2462587T16	COIL CHIP 120nH

Circuit Ref	Motorola Part No.	Description
L5600	2484657R01	Ferrite Bead
L5601	2484657R01	Ferrite Bead
L5611	2484657R01	Ferrite Bead
L5631	2462587T23	COIL CHIP 470nH
Q5510	4813827A26	NPN SML SIG MRF8372
Q5520	4813827D03	G=9.0DB 870MHZ
Q5530	4805537W01	TRANS MOS 1 FET
Q5540	4880225C30	TSTR RF 14W/50W UHF
Q5611	4805128M17	PNP40V .2A
Q5612	4813824A10	NPN 40V .2A
Q5621	4805128M17	PNP40V .2A
R5501	0662057C19	4R7 1/10W 5%
R5502	0662057A21	68 1/16W 5%
R5511	0662057A01	10 1/16W 5%
R5512	0662057A01	10 1/16W 5%
R5513	0662057A57	2k2 1/16W 5%
R5521	0662057A49	1k 1/16W 5%
R5522	0662057A49	1k 1/16W 5%
R5525	0662057C19	4R7 1/10W 5%
R5526	0662057C19	4R7 1/10W 5%
R5527	0662057C19	4R7 1/10W 5%
R5531	0680194M01	10 1W 5%
R5541	0680194M01	10 1W 5%
R5550	0662057A73	10k 1/16W 5%
R5551	0662057A73	10k 1/16W 5%
R5552	0662057A18	51 1/16W 5%
R5553	0683962T51	120 1W 5%
R5611	0662057A73	10k 1/16W 5%
R5612	0662057A56	2k 1/16W 5%
R5613	0662057A49	1k 1/16W 5%
R5614	0662057A18	51 1/16W 5%
R5615	0662057A65	4,7k 1/16W 5%
R5616	0680194M01	10 1W 5%

Circuit Ref	Motorola Part No.	Description
R5617	0680194M01	10 1W 5%
R5621	0662057A45	680 OHMS 5%
R5623	0662057C19	4R7 1/10W 5%
R5624	0662057C19	4R7 1/10W 5%
R5641	0680149M02	THERMISTOR CHIP 100K @25C

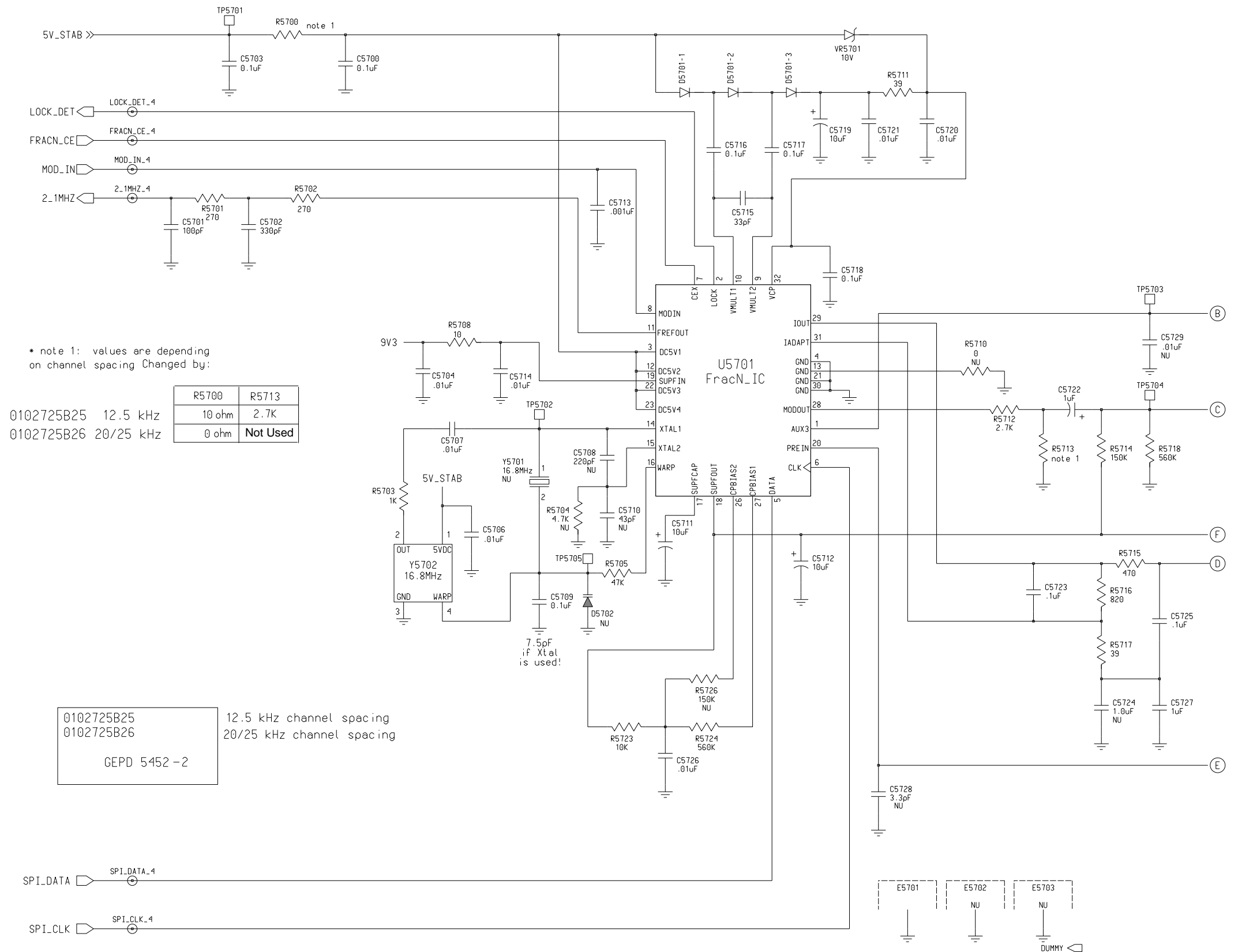

UHF (403-470MHz) Synthesizer Schematic Diagram

**Synthesizer
Parts List**

Circuit Ref	Motorola Part No.	Description
C5700	2113743K15	100nF 16V
C5701	2113740F51	100pF 5% 50V
C5702	2113741F13	330pF 50V
C5703	2113743K15	100nF 16V
C5704	2113741F49	10nF 50V
C5706	2113741F49	10nF 50V
C5707	2113741F49	10nF 50V
C5709	2113743K15	100nF 16V
C5711	2311049A63	TANT CP 10uF 10% 10V
C5712	2311049J26	TANT CP 10uF 20% 16V
C5713	2113741F25	1nF 50V
C5714	2113741F49	10nF 50V
C5715	2113740F39	33pF 5% 50V
C5716	2113743K15	100nF 16V
C5717	2113743K15	100nF 16V
C5718	2113743K15	100nF 16V
C5719	2311049A19	TANT CP 10uF 10% 25V
C5720	2113741F49	10nF 50V
C5721	2113741F49	10nF 50V
C5722	2311049A07	TANT CP 1uF 10% 16V
C5723	2109720D14	CER LOW DIST 100nF
C5725	2109720D14	CER LOW DIST 100nF
C5726	2113741F49	10nF 50V
C5727	0811051A19	MTLZ POLY 1uF 5%
D5701	4802233J09	DIODE TRIPLE SOT143-RH
E5701	2605915V01	SHLD PCB MOUNT 1
R5700	0662057A01 0662057B47	10 1/16W 5% 0 ohms
R5701	0662057A35	270 1/16W 5%
R5702	0662057A35	270 1/16W 5%
R5703	0662057A49	1k 1/16W 5%

Circuit Ref	Motorola Part No.	Description
R5705	0662057A89	47k 1/16W 5%
R5708	0662057A01	10 1/16W 5%
R5711	0662057A15	39 1/16W 5%
R5712	0662057A59	2k7 1/16W 5%
R5713	0662057A59	2k7 1/16W 5% (12.5kHz)
R5714	0662057B02	150k 1/16W
R5715	0662057A41	470 1/16W 5%
R5716	0662057A47	820 1/16W 5%
R5717	0662057A15	39 1/16W 5%
R5718	0662057B16	560k 1/16W 5%
R5723	0662057A73	10k 1/16W 5%
R5724	0662057B16	560k 1/16W 5%
U5701	5105457W72	CC CONT 5105191W59
VR5701	4813830A23	DIODE 10V 5% 20mA 350mW
Y5702	4809863M01	REF OSC 16.8 MHz TEMPUS

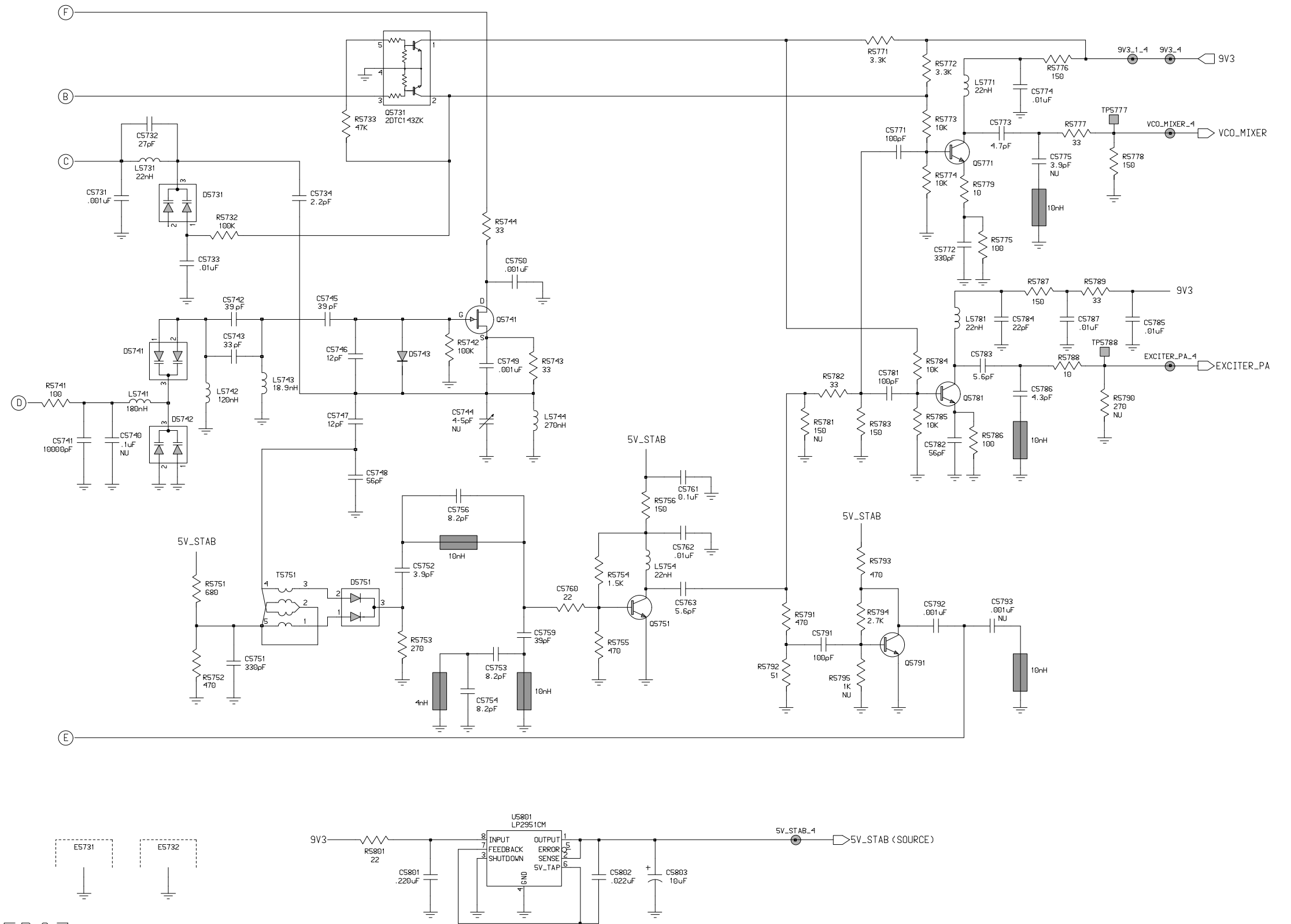

UHF (403-470MHz) Voltage Controlled Oscillator Schematic Diagram

Voltage Controlled Oscillator Parts List

Circuit Ref	Motorola Part No.	Description
C5731	2113741F25	1nF 50V
C5732	2113740F37	27pF 5% 50V
C5733	2113741F49	10nF 50V
C5734	2113740F11	2.2pF 5% 50V
C5741	2113741A45	10nF 50V
C5742	2113740F41	39pF 5% 50V
C5743	2113740F39	33pF 5% 50V
C5745	2113740F41	39pF 5% 50V
C5746	2113740F29	12pF 5% 50V
C5747	2113740F29	12pF 5% 50V
C5748	2113740F45	56pF 5% 50V
C5749	2113741F25	1nF 50V
C5750	2113741F25	1nF 50V
C5751	2113741F13	330pF 50V
C5752	2113740F17	3.9pF 5% 50V
C5753	2113740F25	8.2pF 5% 50V
C5754	2113740F25	8.2pF 5% 50V
C5756	2113740F25	8.2pF 5% 50V
C5759	2113740F41	39pF 5% 50V
C5760	0662057A09	22 1/16W 5%
C5761	2113743K15	100nF 16V
C5762	2113741F49	10nF 50V
C5763	2113740F21	5.6pF 5% 50V
C5771	2113740F51	100pF 5% 50V
C5772	2113741F13	330pF 50V
C5773	2113740F19	4.7pF 5% 50V
C5774	2113741F49	10nF 50V
C5781	2113740F51	100pF 5% 50V
C5782	2113740F45	56pF 5% 50V
C5783	2113740F21	5.6pF 5% 50V
C5784	2113740F35	22pF 5% 50V

Circuit Ref	Motorola Part No.	Description
C5785	2113741F49	10nF 50V
C5786	2113740F18	4.3pF 5%
C5787	2113741F49	10nF 50V
C5791	2113740F51	100pF 5% 50V
C5792	2113741F25	1nF 50V
C5801	2113743A23	220nF 16V
C5802	2113743E07	22nF 16V
C5803	2311049A63	TANT CP 10uF 10% 10V
D5731	4805649Q13	DIODE VCTR 1SV228
D5741	4805649Q13	DIODE VCTR 1SV228
D5742	4805649Q13	DIODE VCTR 1SV228
D5743	4880236E05	DIODE CHIP SCHOTTKY
D5751	4805218N57	DIODE DUAL SCHOTTKY
E5731	2605915V01	SHLD PCB MOUNT 1
E5732	2602641Y01	SHIELD VCO
L5731	2462587T38	COIL CHIP 22nH 5%
L5741	2462587T18	COIL CHIP 180nH
L5742	2462587T16	COIL CHIP 120nH
L5743	2405619V01	COIL HEL MOLDED SMD
L5744	2462587T20	COIL CHIP 270nH
L5754	2462587T38	COIL CHIP 22nH 5%
L5771	2462587T38	COIL CHIP 22nH 5%
L5781	2462587T38	COIL CHIP 22nH 5%
Q5731	4805921T09	XSTR DUAL ROHM FMG8
Q5741	4813823A05	TSTR N-CH RF JFET MMBU310LT1
Q5751	4882022N70	TRANSISTOR NPN
Q5771	4882022N70	TRANSISTOR NPN
Q5781	4882022N70	TRANSISTOR NPN
Q5791	4882022N70	TRANSISTOR NPN
R5732	0662057A97	100k 1/16W
R5733	0662057A89	47k 1/16W 5%
R5741	0662057A25	100 1/16W 5%

Circuit Ref	Motorola Part No.	Description
R5742	0662057A97	100k 1/16W
R5743	0662057A13	33 1/16W 5%
R5744	0662057A13	33 1/16W 5%
R5751	0662057A45	680 Ohms 5%
R5752	0662057A41	470 1/16W 5%
R5753	0662057A35	270 1/16W 5%
R5754	0662057A53	1k5 1/16W 5%
R5755	0662057A41	470 1/16W 5%
R5756	0662057A29	150 1/16W 5%
R5771	0662057A61	3k3 1/16W 5%
R5772	0662057A61	3k3 1/16W 5%
R5773	0662057A73	10k 1/16W 5%
R5774	0662057A73	10k 1/16W 5%
R5775	0662057A25	100 1/16W 5%
R5776	0662057A29	150 1/16W 5%
R5777	0662057A13	33 1/16W 5%
R5778	0662057A29	150 1/16W 5%
R5779	0662057A01	10 1/16W 5%
R5782	0662057A13	33 1/16W 5%
R5783	0662057A29	150 1/16W
R5784	0662057A73	10k 1/16W
R5785	0662057A73	10k 1/16W
R5786	0662057A25	100 1/16W
R5787	0662057A29	150 1/16W
R5788	0662057A01	10 1/16W 5%
R5789	0662057A13	33 1/16W 5%
R5791	0662057A41	470 1/16W
R5792	0662057A18	51 1/16W 5%
R5793	0662057A41	470 1/16W
R5794	0662057A59	2k7 1/16W
R5801	0662057A09	22 1/16W 5%
T5751	2505515V03	XFMR JEDI MIXER SMD 4:1
U5801	5105469E65	IC VLTG REGLTR LP2951C

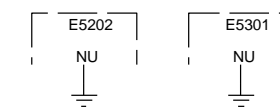
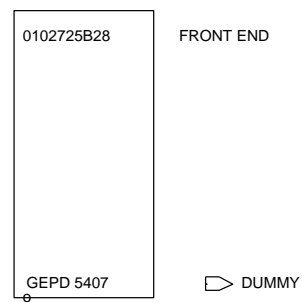
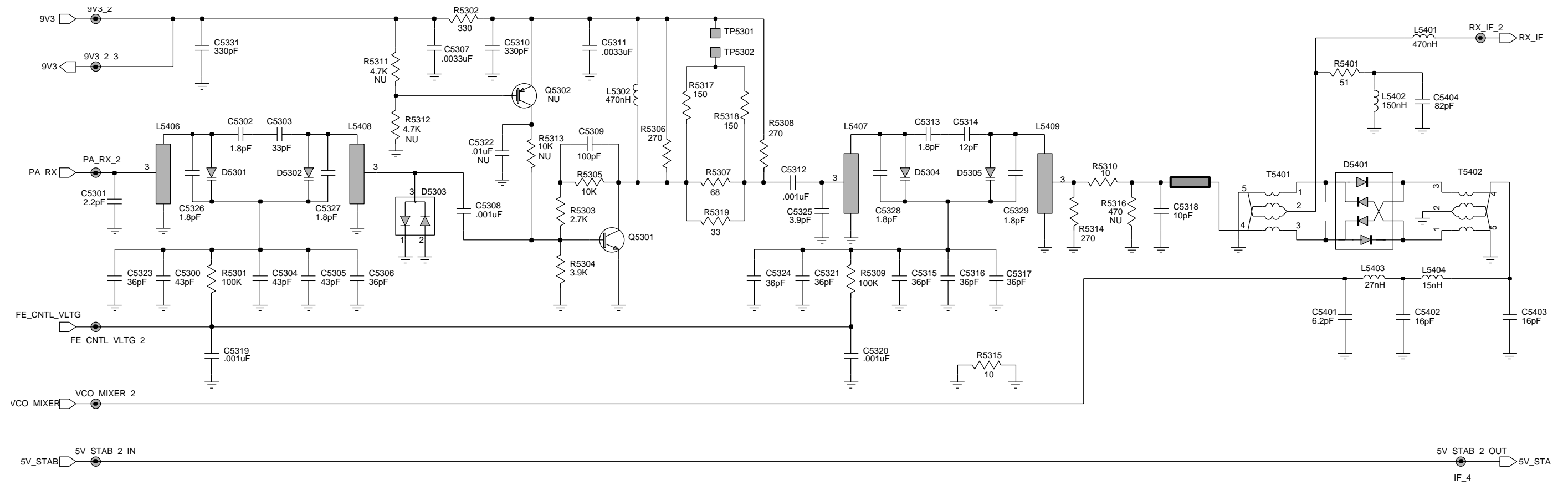

UHF (403-470MHz) RX-FE Schematic Diagram

**RX-FE
Parts List**

Circuit Ref	Motorola Part No.	Description
C5300	2113740F42	43pF 5% 50V
C5301	2113740F11	2.2pF 5% 50V
C5302	2113740F09	1.8pF 5% 50V
C5303	2113740F39	33pF 5% 50V
C5304	2113740F42	43pF 5% 50V
C5305	2113740F42	43pF 5% 50V
C5306	2113740F40	36pF 5% 50V
C5307	2113741F37	3.3nF 50V
C5308	2113741F25	1nF 50V
C5309	2113740F51	100pF 5% 50V
C5310	2113741F13	330pF 50V
C5311	2113741F37	3.3nF 50V
C5312	2113741F25	1nF 50V
C5313	2113740F09	1.8pF 5% 50V
C5314	2113740F29	12pF 5% 50V
C5315	2113740F40	36pF 5% 50V
C5316	2113740F40	36pF 5% 50V
C5317	2113740F40	36pF 5% 50V
C5318	2113740F27	10pF 5% 50V
C5319	2113741F25	1nF 50V
C5320	2113741F25	1nF 50V
C5321	2113740F40	36pF 5% 50V
C5323	2113740F40	36pF 5% 50V
C5324	2113740F40	36pF 5% 50V
C5325	2113740F17	3.9pF 5% 50V
C5326	2113740F09	1.8pF 5% 50V
C5327	2113740F09	1.8pF 5% 50V
C5328	2113740F09	1.8pF 5% 50V
C5329	2113740F09	1.8pF 5% 50V
C5331	2113741F13	330pF 50V
C5401	2113740F22	6.2pF 5% 50V

Circuit Ref	Motorola Part No.	Description
C5402	2113740F32	16pF 5% 50V
C5403	2113740F32	16pF 5% 50V
C5404	2113740F49	82pF 5% 50V
D5301	4862824C01	VARACTOR CHIP
D5302	4862824C01	VARACTOR CHIP
D5303	4880154K03	DUAL SCHOTTKY SOT23
D5304	4862824C01	DIODE VARACTOR
D5305	4862824C01	DIODE VARACTOR
D5401	4880174R01	QUAD SOIC 8 PIN
L5302	2462587T23	COIL CHIP 470nH
L5401	2462587T23	COIL CHIP 470nH
L5402	2462587T17	COIL CHIP 150nH
L5403	2462587X46	IND CHIP LO-PRO 27.0 N
L5404	2462587X43	IND CHIP LO-PRO 15.0 N
Q5301	4882022N70	TRANSISTOR NPN
R5301	0662057A97	100k 1/16W
R5302	0662057A37	330 1/16W 5%
R5303	0662057A59	2k7 1/16W 5%
R5304	0662057A63	3k9 1/16W 5%
R5305	0662057A73	10k 1/16W 5%
R5306	0662057A35	270 1/16W 5%
R5307	0662057A21	68 1/16W 5%
R5308	0662057A35	270 1/16W 5%
R5309	0662057A97	100k 1/16W
R5310	0662057A01	10 1/16W 5%
R5314	0662057A35	270 1/16W 5%
R5315	0680194M01	10 1W 5%
R5317	0662057A29	150 1/16W 5%
R5318	0662057A29	150 1/16W 5%
R5319	0662057A13	33 1/16W 5%
R5401	0662057A18	51 1/16W 5%
T5401	2505515V03	XFMR JEDI MIXER SMD 4:1
T5402	2505515V04	XMFR MIXER 5:1

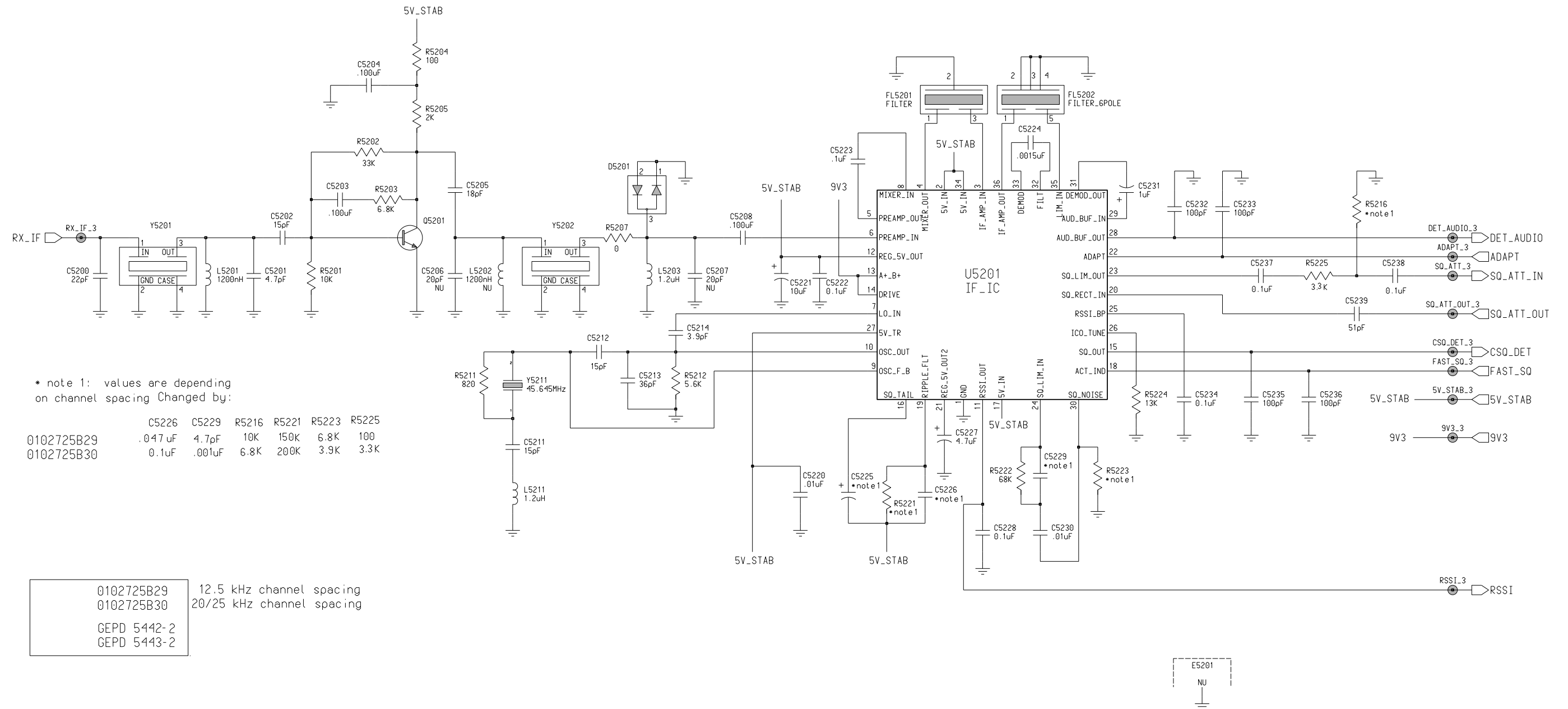

**RX-IF
Parts List**

Circuit Ref	Motorola Part No.	Description
C5200	2113740F35	22pF 5% 50V
C5201	2113740F19	4.7pF 5% 50V
C5202	2113740F31	15pF 5% 50V
C5203	2113743A19	100nF 16V
C5204	2113743A19	100nF 16V
C5205	2113740F33	18pF 5% 50V
C5208	2113743A19	100nF 16V
C5211	2113740F31	15pF 5% 50V
C5212	2113740F31	15pF 5% 50V
C5213	2113740F40	36pF 5% 50V
C5214	2113740F17	3.9pF 5% 50V
C5220	2113741F49	10nF 50V
C5221	2311049J25	TANT CP 10uF 10% 16V
C5222	2113743K15	100nF 16V
C5223	2113743E20	100nF 16V
C5224	2113741F29	1.5nF 50V
C5225	2311049J11	TANT CP 4.7uF 10% 16V
C5226	2113743K07 2113743K15	47nF 16V (12.5kHz) 100nF 16V (20/25kHz)
C5227	2311049J11	TANT CP 4.7uF 10% 16V
C5228	2113743K15	100nF 16V
C5229	2113741F41 2113741F25	4.7nF 50V (12.5kHz) 1nF (20/25kHz)
C5230	2113741F49	10nF 50V
C5231	2311049A07	TANT CP 1uF 10% 16V
C5232	2113740F51	100pF 5% 50V
C5233	2113740F51	100pF 5% 50V
C5234	2113743K15	100nF 16V
C5235	2113740F51	100pF 5% 50V
C5236	2113740F51	100pF 5% 50V
C5237	2113743K15	100nF 16V
C5238	2113743K15	100nF 16V Y5V

Circuit Ref	Motorola Part No.	Description
C5239	2113740F44	51pF 5% 50V
D5201	4880154K03	DUAL SCHOTTKY SOT23
FL5201	9180098D04 9180098D06	FILTER CER 4-EL 455kHz (12.5kHz) FILTER CER 4-EL 455kHz (20/25kHz)
FL5202	9180097D04 9180097D06	FILTER CER 6-EL 455kHz (12.5kHz) FILTER CER 6-EL 455kHz (20/25kHz)
L5201	2462587N69	CHIP IND 1200 NH
L5203	2483411T74	Inductor Chip Shielded
L5211	2483411T74	Inductor Chip Shielded
Q5201	4882022N70	Transistor NPN
R5201	0662057A73	10k 1/16W 5%
R5202	0662057A85	33k 1/16W 5%
R5203	0662057A69	6k8 1/16W 5%
R5204	0662057A25	100 1/16W 5%
R5205	0662057A56	2k 1/16W 5%
R5207	0662057B47	0 1/16W
R5211	0662057A47	820 1/16W 5%
R5212	0662057A67	5k6 1/16W 5%
R5216	0662057A73 0662057A69	10k 1/16W 5% (12.5kHz) 4k7 1/16W 5% (20/25kHz)
R5221	0662057B02 0662057B05	150k 1/16W (12.5kHz) 200k 1/16W (20/25kHz)
R5222	0662057A93	68k 1/16W 5%
R5223	0662057A69 0662057A63	6k8 1/16W 5% (12.5kHz) 3k9 1/16W 5% (20/25kHz)
R5224	0662057A76	13k 1/16W 5%
R5225	0662057A25 0662057A61	100 1/16W 5% (12.5kHz) 3k3 1/16W 5% (20/25kHz)
U5201	5180207R01	IF IC
Y5201	9102651Y01 9102652Y01	XTAL FLTR 45.1MHz 12.5KHz 80dB XTAL FLTR 45.1MHz 20/25KHz 80dB

Circuit Ref	Motorola Part No.	Description
Y5202	9102651Y02 9102652Y02	XTAL FLTR 45.1MHz 12.5KHz 60dB XTAL FLTR 45.1MHz 20/25KHz 60dB
Y5211	4802653Y01	XTAL OSC 44.645MHz

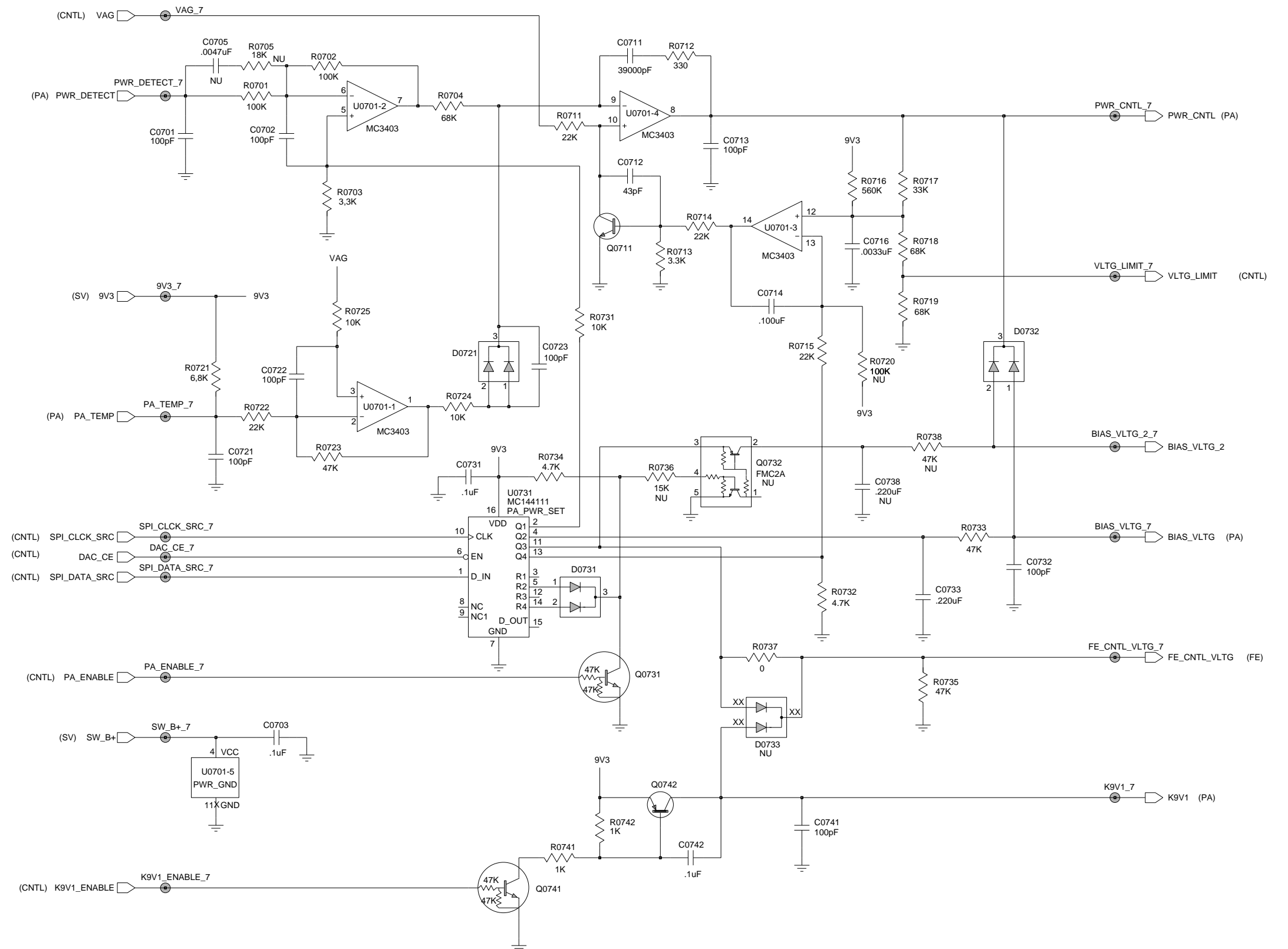

VHF (136-174MHz) Power Control Schematic Diagram

Power Control Parts List

Circuit Ref	Motorola Part No.	Description
C0701	2113740F51	100pF 5% 50V
C0702	2113740F51	100pF 5% 50V
C0703	2113743E20	100nF 16V
C0711	2113741A59	39000pF
C0712	2113740F42	43pF 5% 50V
C0713	2113740F51	100pF 5% 50V
C0714	2113743A19	100nF 16V
C0716	2113741F37	3.3nF 50V
C0721	2113740F51	100pF 5% 50V
C0722	2113740F51	100pF 5% 50V
C0723	2113740F51	100pF 5% 50V
C0731	2113743E20	100nF 16V
C0732	2113740F51	100pF 5% 50V
C0733	2113743A23	220nF 16V
C0741	2113740F51	100pF 5% 50V
C0742	2113743E20	100nF 16V
D0721	4813833C02	DIODE DUAL SOT MMBD6100
D0731	4813833C02	DIODE DUAL SOT MMBD6100
D0732	4813833C02	DIODE DUAL SOT MMBD6100
Q0711	4813824A10	NPN 40V .2A B=50-150
Q0731	4880048M01	NPN DIG 47k/47k
Q0741	4880048M01	NPN DIG 47k/47k
Q0742	4805128M27	PNP SOT89 BSR33
R0701	0662057A97	100k 1/16W
R0702	0662057A97	100k 1/16W
R0703	0662057A61	3k3 1/16W 5%
R0704	0662057A93	68k 1/16W 5%
R0711	0662057A81	22k 1/16W 5%
R0712	0662057A37	330 1/16W 5%

Circuit Ref	Motorola Part No.	Description
R0713	0662057A61	3k3 1/16W 5%
R0714	0662057A81	22k 1/16W 5%
R0715	0662057A81	22k 1/16W 5%
R0716	0662057B16	560k 1/16W 5%
R0717	0662057A85	33k 1/16W 5%
R0718	0662057A93	68k 1/16W 5%
R0719	0662057A93	68k 1/16W 5%
R0721	0662057A69	6k8 1/16W 5%
R0722	0662057A81	22k 1/16W 5%
R0723	0662057A89	47k 1/16W 5%
R0724	0662057A73	10k 1/16W 5%
R0725	0662057A73	10k 1/16W 5%
R0731	0662057A31	22k 1/16W 5%
R0732	0662057A65	4k7 1/16W 5%
R0733	0662057A89	47k 1/16W 5%
R0734	0662057A65	4k7 1/16W 5%
R0735	0662057A89	47k 1/16W 5%
R0737	0662057B47	0 1/16W
R0741	0662057A49	1k 1/16W 5%
R0742	0662057A49	1k 1/16W 5%
U0701	5183222M49	IC QUAD OPAMP __3403_
U0731	5113811G02	IC D/A CONV & BIT 4 CHAN W/SPI

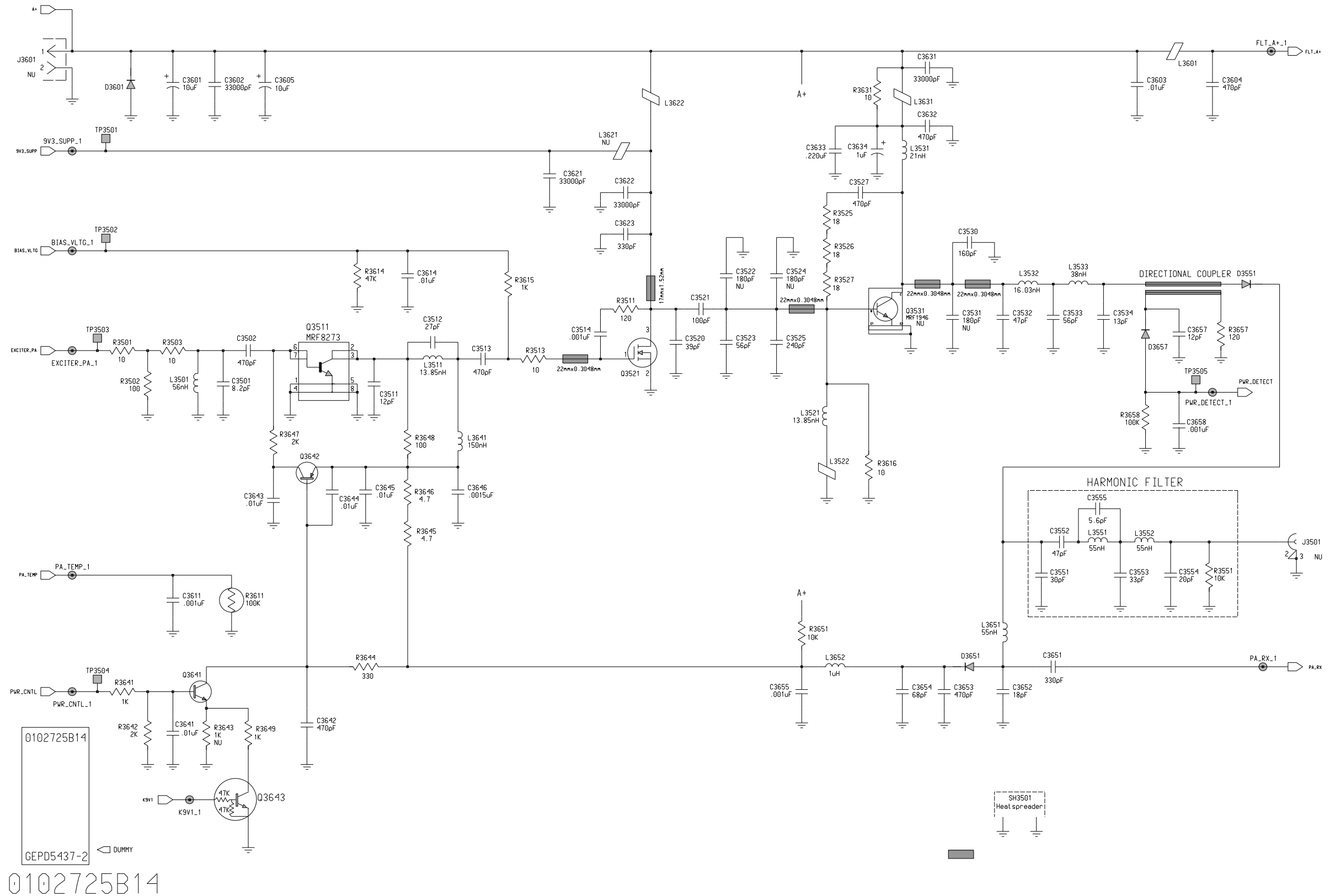

VHF (136-174MHz) Power Amplifier 5-25W Schematic Diagram

**Power Amplifier 5-25W
Parts List**

Circuit Ref	Motorola Part No.	Description
C3501	2113740F25	8.2pF 5% 50V
C3502	2113741F17	470pF 50V
C3511	2113740F29	12pF 5% 50V
C3512	2113740F37	27pF 5% 50V
C3513	2113741F17	470pF 50V
C3514	2113741F25	1nF 50V
C3520	2111078B32	39pF 5% 100V
C3521	2111078B42	100pF 5% 100V
C3523	2111078B36	56pF 5% 100V
C3525	2111078B52	240pF 5% 100V
C3527	2111078B59	470pF 5% 100V
C3530	2111078B48	160pF 5% 100V
C3532	2111078B34	47pF 5% 100V
C3533	2111078B36	56pF 5% 100V
C3534	2111078B16	13pF 5% 100V
C3551	2111078B27	30pF 5% 100V
C3552	2111078B34	47pF 5% 100V
C3553	2111078B29	33pF 5% 100V
C3554	2111078B21	20pF 5% 100V
C3555	2111078B07	5.6pF .25% 100V
C3601	2380090M24	10uF 50V 20%
C3602	2113741A57	33nF 50V
C3603	2113741F49	10nF 50V
C3604	2113741F17	470pF 50V
C3605	2311049A45	TANTCHIP 10 10 35
C3611	2113741F25	1nF 50V
C3614	2113741F49	10nF 50V
C3621	2113741A57	33nF 50V
C3622	2113741A57	33nF 50V
C3623	2113740A67	330nF 50V
C3631	2113741A57	33nF 50V

Circuit Ref	Motorola Part No.	Description
C3632	2111078B59	470pF 5% 100V
C3633	2113743A23	220nF 10% 16V
C3634	2311049A08	TANTCHIP 1 10 35 A/P
C3641	2113741F49	10nF 50V
C3642	2113741F17	470pF 5% 50V
C3643	2113741F49	10nF 50V
C3644	2113741F49	10nF 50V
C3645	2113741F49	10nF 50V
C3646	2113741F29	1.5nF 50V
C3651	2113740A67	330pF 5% 50V
C3652	2113740F33	18pF 5% 50V
C3653	2111078B59	470pF 5%100V
C3654	2113740F47	68pF 5% 50V
C3655	2113741F25	1nF 50V
C3657	2113740F29	12pF 5% 50V
C3658	2113741F25	1nF 50V
D3551	4802482J02	PIN DIODE SMD
D3601	4813832B35	24V TRANS SUP 1.5
D3651	4802482J02	PIN DIODE SMD
D3657	4880236E05	DIODE HOTCAR SOT 23
J3501	0905902V01	PWR CONNECTOR 2 PIN
J3601	0905901V02	BNC CONNECTOR
L3501	2462587T12	INDCHIP 56NH 5% LOW
L3511	2460591C23	Coil Air Wound Induc 13.85
L3521	2460591C23	Coil Air Wound Induc 13.85
L3522	2484657R01	INDUCTOR BEADCHIP
L3531	2460591X01	Coil Air Wound Sq. 21NH
L3532	2460591L29	Coil Air Wound Induc 16.03
L3533	2460591M77	Coil Air Wound Induc 38.13
L3551	2460591W04	COIL SQUARE RFD-022-16
L3552	2460591W04	COIL SQUARE RFD-022-16
L3601	2484657R01	INDUCTOR BEADCHIP
L3622	2484657R01	INDUCTOR BEADCHIP

Circuit Ref	Motorola Part No.	Description
L3631	2484657R01	INDUCTOR BEADCHIP
L3641	2462587T17	INDCHIP 150NH 5% LOW
L3651	2460591W04	COIL SQUARE RFD-022-16
L3652	2462587T30	INDCHIP 1000NH 5% LOW
Q3511	4813827A26	TSTR NPN SML SIG MRF8372 8372
Q3521	4805847W01	TSTR
Q3531	4880225C22	TSTR RF PWR
Q3641	4813824A10	XSTR NPN 40V .2A GENP B=50-150
Q3642	4813824A17	XSTR PNP40V .2A GENP B=100-300
Q3643	4880048M01	TSTR NPN DIG 47K/47K
R3501	0662057A01	10 1/16W 5%
R3502	0662057A25	100 1/16W 5%
R3503	0662057A01	10 1/16W 5%
R3511	0683962T51	120 5%
R3513	0662057A01	10 1/16W 5%
R3525	0680194M07	18 5% 1W
R3526	0680194M07	18 5% 1W
R3527	0680194M07	18 5% 1W
R3551	0662057A73	10K 1/16W 5%
R3611	0680149M02	THERM 100K @25C
R3614	0662057A89	47K 5%
R3615	0662057A49	1K 5%
R3616	0680194M01	10 5% 1W
R3631	0680194M01	10 5% 1W
R3641	0662057A49	1K 5%
R3642	0662057A56	2K 5%
R3644	0662057A37	330 5%
R3645	0662057C19	4.7 5%
R3646	0662057C19	4.7 5%
R3647	0662057A56	2K 5%
R3648	0662057A25	100 5%

Circuit Ref	Motorola Part No.	Description
R3649	0662057A49	1000 OHMS 5%
R3651	0662057A73	10K OHMS 5%
R3657	0683962T51	120 5-1
R3658	0662057A97	100K 5%
SH3501	2602642Y01	HEATSPREADER

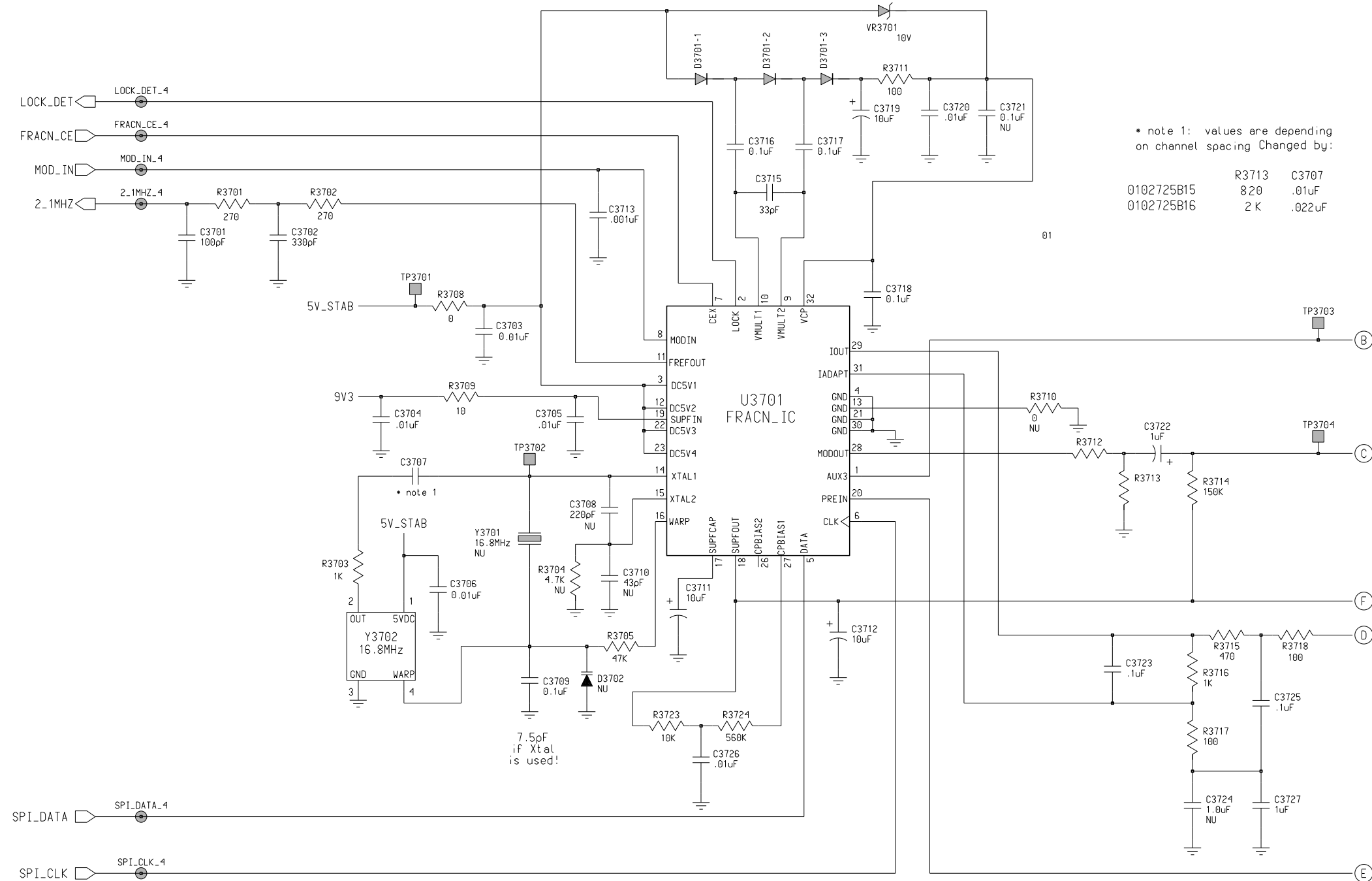

* note 1: values are depending on channel spacing Changed by:

0102725B15	R3713	C3707
0102725B16	820	.01uF
	2 K	.022uF

0102725B15	GEPD5438-3	12.5 kHz channel spacing
0102725B16	GEPD5439-3	20/25 kHz channel spacing

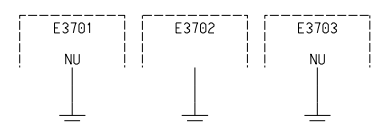

VHF (136-174MHz) Synthesizer Schematic Diagram

Synthesizer Parts List

Circuit Ref	Motorola Part No.	Description
C3701	2113740F51	100pF 5% 50V
C3702	2113741F13	330pF 50V
C3703	2113743E20	100nF
C3704	2113741F49	10nF 50V
C3705	2113741F49	10nF 50V
C3706	2113743E20	100nF
C3707	2113741F49	10nF 50V (12.5kHz)
C3707	2113743E07	22nF 50V (20/25kHz)
C3709	2113743E20	100nF
C3711	2311049A63	TANT CP 10uF
C3712	2311049J26	TANT CP 10uF
C3713	2113741F25	1nF 50V
C3715	2113740F39	33pF 50V
C3716	2113743E20	100nF
C3717	2113743E20	100nF
C3718	2113743E20	100nF
C3719	2311049A19	TANT CP 10uF 10% 25V
C3720	2113741F49	10nF 50V
C3722	2311049A07	1uF 10% 16V
C3723	2109720D14	100nF
C3725	2109720D14	100nF
C3726	2113741F49	10nF 50V
C3727	0811051A19	1uF 5%
D3701	4802233J09	TRIPLE SOT143-RH
E3702	2605915V01	SHLD PCB MOUNT 1
R3701	0662057A35	270 1/16W 5%
R3702	0662057A35	270 1/16W 5%
R3703	0662057A49	1k 1/16W 5%
R3705	0662057A89	47k 1/16W 5%
R3708	0662057B47	0 Ohm
R3709	0662057A01	10 1/16W 5%

Circuit Ref	Motorola Part No.	Description
R3711	0662057A25	100 1/16W 5%
R3712	0662057A59	2k7 1/16W 5%
R3713	0662057A47	820 1/16W 5%
R3714	0662057B02	150k 1/16W
R3715	0662057A41	470 1/16W
R3716	0662057A49	1k 1/16W
R3717	0662057A25	100 1/16W 5%
R3718	0662057A25	100 1/16W 5%
R3723	0662057A73	10k 1/16W 5%
R3724	0662057B16	560k 1/16W 5%
U3701	5105457W72	CC CONT 5105191W59
VR3701	4813830A23	DIODE 10V 5% 20mA 350mW
Y3702	4809863M01	Crystal Quartz Ref Osc 16.8 MHz TEMPUS

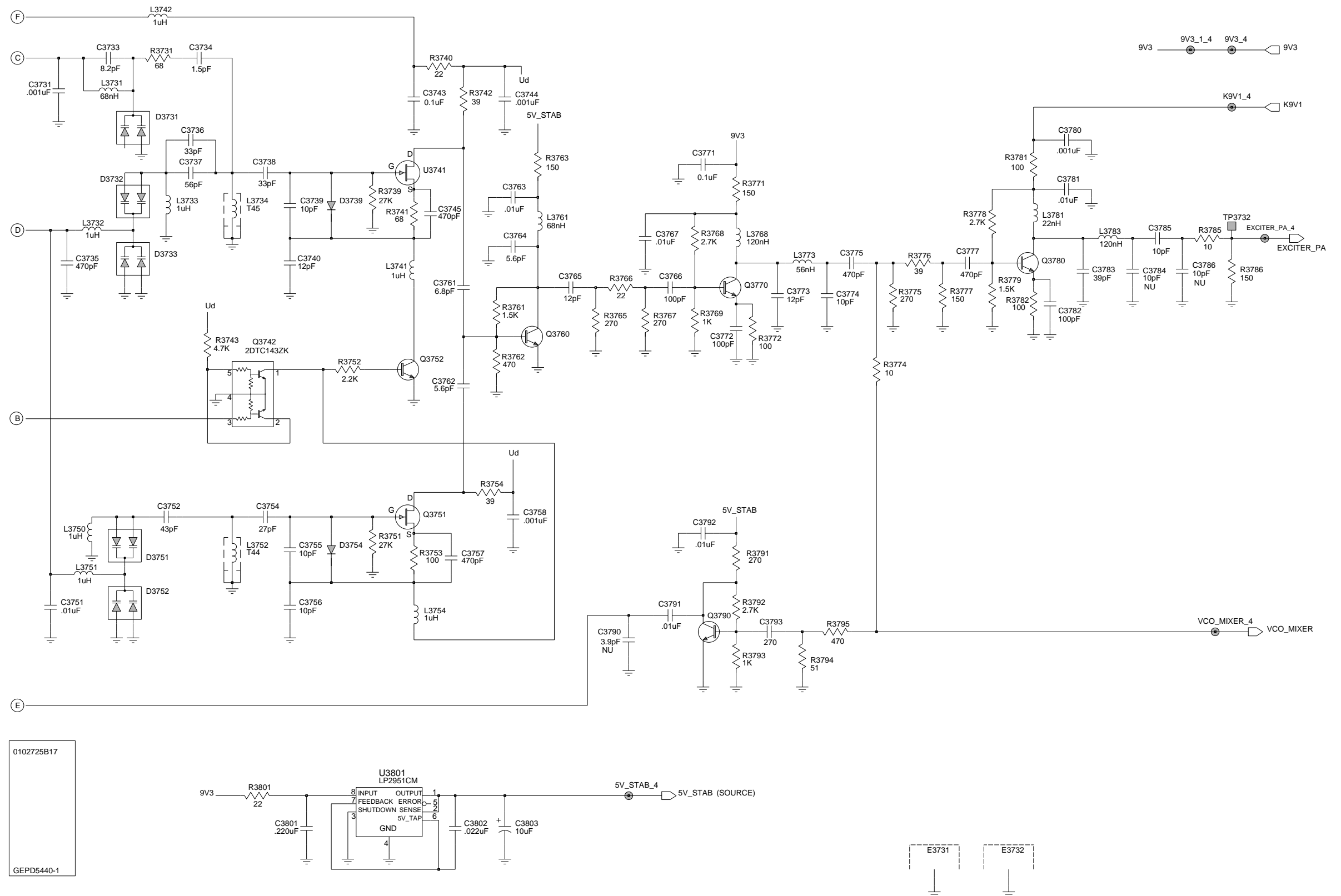

VHF (136-174MHz) Voltage Controlled Oscillator Schematic Diagram

Voltage Controlled Oscillator Parts List

Circuit Ref	Motorola Part No.	Description
C3731	2113741F25	1nF 50V
C3733	2113740F25	8.2pF 5% 50V
C3734	2113740F07	1.5pF 5% 50V
C3735	2113741F17	470pF 50V
C3736	2113740F39	33pF 5% 50V
C3737	2113740F45	56pF 5% 50V
C3738	2113740F39	33pF 5% 50V
C3739	2113740F27	10pF 5% 50V
C3740	2113740F29	12pF 5% 50V
C3743	2113743K15	100nF 16V
C3744	2113741F25	1nF 50V
C3745	2113741F17	470pF 50V
C3751	2109720D01	LOW DIST 10nF
C3752	2113740F42	43pF 5% 50V
C3754	2113740F37	27pF 5% 50V
C3755	2113740F27	10pF 5% 50V
C3756	2113740F27	10pF 5% 50V
C3757	2113741F17	470pF 50V
C3758	2113741F25	1nF 50V
C3761	2113740F23	6.8pF 5% 50V
C3762	2113740F21	5.6pF 5% 50V
C3763	2113741F49	10nF 50V
C3764	2113740F21	5.6pF 5% 50V
C3765	2113740F29	12pF 5% 50V
C3766	2113740F51	100pF 5% 50V
C3767	2113741F49	10nF 50V X7R
C3771	2113743K15	100nF 16V
C3772	2113740F51	100pF 5% 50V
C3773	2113740F29	12pF 5% 50V
C3774	2113740F27	10pF 5% 50V
C3775	2113741F17	470pF 50V

Circuit Ref	Motorola Part No.	Description
C3777	2113741F17	470pF 50V
C3780	2113741F25	1nF 50V
C3781	2113741F49	10nF 50V
C3782	2113740F51	100pF 5% 50V
C3783	2113740F41	39pF 5%
C3785	2113740F27	10pF 5%
C3791	2113741F49	10nF 50V
C3792	2113741F49	10nF 50V
C3793	2113741F49	10nF 50V
C3801	2113743A23	220nF 16V
C3802	2113743E07	22nF 16V
C3803	2311049A63	TANT CP 10uF 10% 10V
D3731	4805649Q13	VCTR 1SV228 SOT23
D3732	4805649Q13	VCTR 1SV228 SOT23
D3733	4805649Q13	VCTR 1SV228 SOT23
D3739	4880236E05	SCHOTTKY
D3751	4805649Q13	VCTR 1SV228 SOT23
D3752	4805649Q13	VCTR 1SV228 SOT23
D3754	4880236E05	SCHOTTKY
E3732	2605915V01	SHLD PCB MOUNT
L3731	2462587T13	COIL CHIP 68nH
L3732	2462587T30	COIL CHIP 1uH
L3733	2462587T30	COIL CHIP 1uH
L3734	0105950T45	HELICAL MOLDED FIN .175
L3741	2462587T30	COIL CHIP 1uH
L3742	2462587T30	COIL CHIP 1uH
L3750	2462587T30	COIL CHIP 1uH
L3751	2462587T30	COIL CHIP 1uH
L3752	0105950T44	HELICAL MOLDED FIN .175
L3754	2462587T30	COIL CHIP 1uH
L3761	2462587T13	COIL CHIP 68nH
L3768	2462587T16	COIL CHIP 120nH
L3773	2462587T12	COIL CHIP 56nH

Circuit Ref	Motorola Part No.	Description
L3781	2462587T38	COIL CHIP 22nH
L3783	2462587T16	COIL CHIP 120nH
Q3742	4805921T09	XSTR DUAL ROHM FMG8
Q3751	4813823A05	N-CH RF JFET MMBU310LT1
Q3752	4813824A10	NPN 40V .2A
Q3760	4813827A07	NPN SML SIG MMBR9
Q3770	4813827A07	NPN SML SIG MMBR9
Q3780	4813827A07	NPN SML SIG MMBR9
Q3790	4813827A07	NPN SML SIG MMBR9
R3731	0662057A21	68 1/16W 5%
R3739	0662057A83	27k 1/16W 5%
R3740	0662057A09	22 1/16W 5%
R3741	0662057A21	68.5 1/16W 5%
R3742	0662057A15	39 1/16W 5%
R3743	0662057A65	4k7 1/16W 5%
R3751	0662057A83	27k 1/16W 5%
R3752	0662057A57	2k2 1/16W 5%
R3753	0662057A25	100 1/16W 5%
R3754	0662057A15	39 1/16W 5%
R3761	0662057A53	1k5 1/16W 5%
R3762	0662057A41	470 1/16W 5%
R3763	0662057A29	150 1/16W 5%
R3765	0662057A35	270 1/16W 5%
R3766	0662057A09	22 1/16W 5%
R3767	0662057A35	270 1/16W 5%
R3768	0662057A59	2k7 1/16W 5%
R3769	0662057A49	1k 1/16W 5%
R3771	0662057A29	150 1/16W 5%
R3772	0662057A25	100 1/16W 5%
R3774	0662057A01	10 1/16W 5%
R3775	0662057A35	270 1/16W 5%
R3776	0662057A15	39 1/16W 5%

Circuit Ref	Motorola Part No.	Description
R3777	0662057A29	150 1/16W 5%
R3778	0662057A59	2k7 1/16W 5%
R3779	0662057A53	1.5k 1/16W 5%
R3781	0662057A25	100 1/16W 5%
R3782	0662057A25	100 1/16W 5%
R3785	0662057A01	10 1/16W 5%
R3786	0662057A29	150 1/16W 5%
R3791	0662057A35	270 1/16W 5%
R3792	0662057A59	2k7 1/16W 5%
R3793	0662057A49	1k 1/16W 5%
R3794	0662057A18	51 1/16W 5%
R3795	0662057A41	470 1/16W 5%
R3801	0662057A09	22 1/16W 5%
U3741	4813823A05	N-CH RF JFET MMBU310LT1
U3801	5105469E65	VLTG REGLTR LP2951C

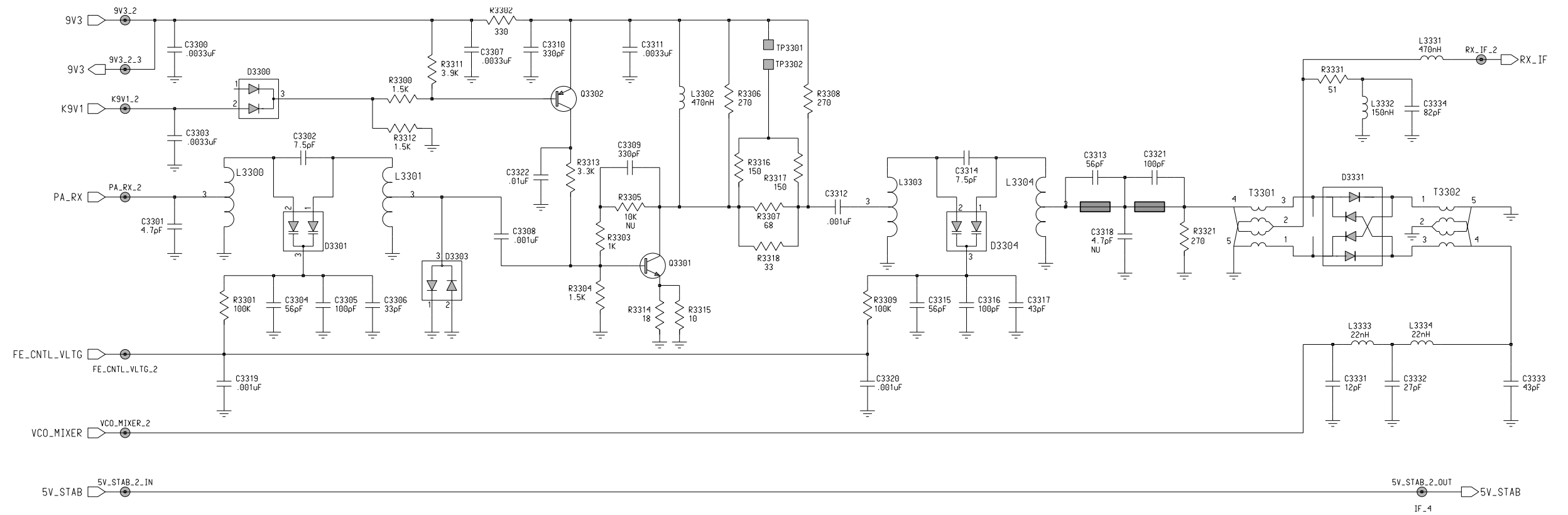

0102725B18
 GEPD5441-1 DUMMY
 0102725B18

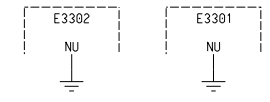

RX-FE Parts List

Circuit Ref	Motorola Part No.	Description
C3300	2113741F37	3.3nF 50V
C3301	2113740F19	4.7pF 5% 50V
C3302	2113740F24	7.5pF 5% 50V
C3303	2113741F37	3.3nF 50V
C3304	2113740F45	56pF 5% 50V
C3305	2113740F51	100pF 5% 50V
C3306	2113740F39	33pF 5% 50V
C3307	2113741F37	3.3nF 50V
C3308	2113741F25	1nF 50V
C3309	2113741F13	330pF 50V
C3310	2113741F13	330pF 50V
C3311	2113741F37	3.3nF 50V
C3312	2113741F25	1nF 50V
C3313	2113740F45	56pF 5% 50V
C3314	2113740F24	7.5pF 5% 50V
C3315	2113740F45	56pF 5% 50V
C3316	2113740F51	100pF 5% 50V
C3317	2113740F42	43pF 5% 50V
C3319	2113741F25	1nF 50V
C3320	2113741F25	1nF 50V
C3321	2113741F51	100pF 5% 50V
C3322	2113741F49	10nF 50V
C3331	2113740F29	12pF 5% 50V
C3332	2113740F37	27pF 5% 50V
C3333	2113740F42	43pF 5% 50V
C3334	2113740F49	82pF 5% 50V
D3300	4813833C02	DUAL SOT MMBD6100
D3301	4805649Q13	VCTR 1SV228 SOT23
D3303	4880154K03	DUAL SCHOTTKY SOT23
D3304	4805649Q13	VCTR 1SV228 SOT23
D3331	4880174R01	QUAD SOIC 8 PIN

Circuit Ref	Motorola Part No.	Description
L3302	2462587T23	COIL CHIP 470nH
L3331	2462587T23	COIL CHIP 470nH
L3332	2462587T17	COIL CHIP 150nH
L3333	2462587T38	COIL CHIP 22nH 5%
L3334	2462587T38	COIL CHIP 22nH 5%
Q3301	4813827A07	NPN SML SIG MMBR9
Q3302	4813824A17	XSTR PNP40V .2A
R3300	0662057A53	1k5 1/16W 5%
R3301	0662057A97	100k 1/16W
R3302	0662057A37	330 1/16W 5%
R3303	0662057A49	1k 1/16W 5%
R3304	0662057A53	1k5 1/16W 5%
R3306	0662057A35	270 1/16W 5%
R3307	0662057A21	68 1/16W 5%
R3308	0662057A35	270 1/16W 5%
R3309	0662057A97	100k 1/16W
R3311	0662057A63	3k9 31/16W 5%
R3312	0662057A53	1k5 1/16W 5%
R3313	0662057A61	3k3 1/16W 5%
R3314	0662057A07	18 1/16W 5%
R3315	0662057A01	10 1/16W 5%
R3316	0662057A29	150 1/16W 5%
R3317	0662057A29	150 1/16W 5%
R3318	0662057A13	33 1/16W 5%
R3321	0662057A35	270 1/16W 5%
R3331	0662057A18	51 1/16W 5%
T3301	2505515V03	XFMR JEDI MIXER SMD 4:1
T3302	2505515V03	XFMR JEDI MIXER SMD 4:1

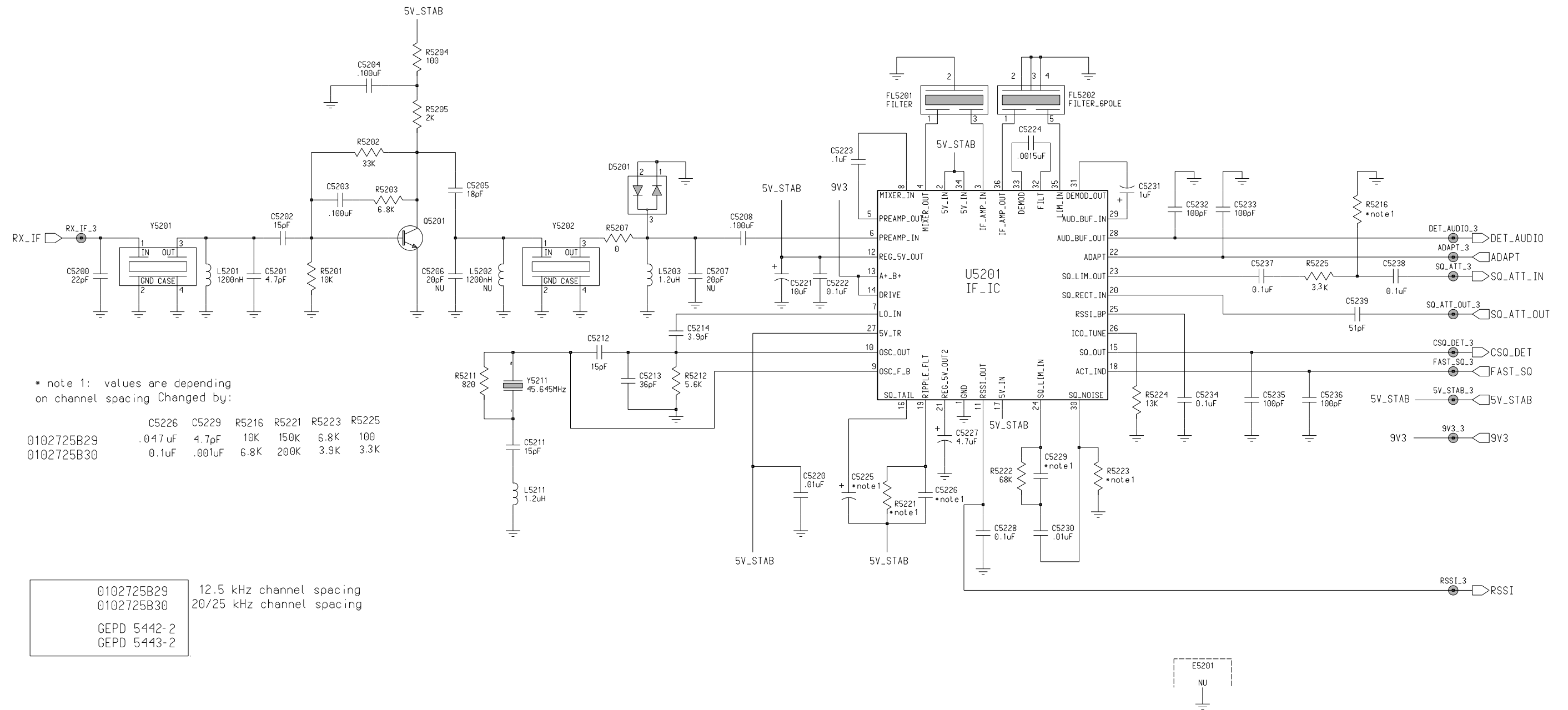

**RX-IF
Parts List**

Circuit Ref	Motorola Part No.	Description
C5200	2113740F35	22pF 5% 50V
C5201	2113740F19	4.7pF 5% 50V
C5202	2113740F31	15pF 5% 50V
C5203	2113743A19	100nF 16V
C5204	2113743A19	100nF 16V
C5205	2113740F33	18pF 5% 50V
C5208	2113743A19	100nF 16V
C5211	2113740F31	15pF 5% 50V
C5212	2113740F31	15pF 5% 50V
C5213	2113740F40	36pF 5% 50V
C5214	2113740F17	3.9pF 5% 50V
C5220	2113741F49	10nF 50V
C5221	2311049J25	TANT CP 10uF 10% 16V
C5222	2113743K15	100nF 16V
C5223	2113743E20	100nF 16V
C5224	2113741F29	1.5nF 50V
C5225	2311049J11	TANT CP 4.7uF 10% 16V
C5226	2113743K07 2113743K15	47nF 16V (12.5kHz) 100nF 16V (20/25kHz)
C5227	2311049J11	TANT CP 4.7uF 10% 16V
C5228	2113743K15	100nF 16V
C5229	2113741F41 2113741F25	4.7nF 50V (12.5kHz) 1nF (20/25kHz)
C5230	2113741F49	10nF 50V
C5231	2311049A07	TANT CP 1uF 10% 16V
C5232	2113740F51	100pF 5% 50V
C5233	2113740F51	100pF 5% 50V
C5234	2113743K15	100nF 16V
C5235	2113740F51	100pF 5% 50V
C5236	2113740F51	100pF 5% 50V
C5237	2113743K15	100nF 16V
C5238	2113743K15	100nF 16V

Circuit Ref	Motorola Part No.	Description
C5239	2113740F44	51pF 5% 50V
D5201	4880154K03	DUAL SCHOTTKY SOT23
FL5201	9180098D04 9180098D06	FILTER CER 4-EL 455kHz (12.5kHz) FILTER CER 4-EL 455kHz (20/25kHz)
FL5202	9180097D04 9180097D06	FILTER CER 6-EL 455kHz (12.5kHz) FILTER CER 6-EL 455kHz (20/25kHz)
L5201	2462587N69	CHIP IND 1200 NH
L5203	2483411T74	Inductor Chip Shielded
L5211	2483411T74	Inductor Chip Shielded
Q5201	4882022N70	Transistor NPN
R5201	0662057A73	10k 1/16W 5%
R5202	0662057A85	33k 1/16W 5%
R5203	0662057A69	6k8 1/16W 5%
R5204	0662057A25	100 1/16W 5%
R5205	0662057A56	2k 1/16W 5%
R5207	0662057B47	0 1/16W
R5211	0662057A47	820 1/16W 5%
R5212	0662057A67	5k6 1/16W 5%
R5216	0662057A73 0662057A69	10k 1/16W 5% (12.5kHz) 4k7 1/16W 5% (20/25kHz)
R5221	0662057B02 0662057B05	150k 1/16W (12.5kHz) 200k 1/16W (20/25kHz)
R5222	0662057A93	68k 1/16W 5%
R5223	0662057A69 0662057A63	6k8 1/16W 5% (12.5kHz) 3k9 1/16W 5% (20/25kHz)
R5224	0662057A76	13k 1/16W 5%
R5225	0662057A25 0662057A61	100 1/16W 5% (12.5kHz) 3k3 1/16W 5% (20/25kHz)
U5201	5180207R01	IF IC
Y5201	9102651Y01 9102652Y01	XTAL FLTR 45.1MHz 12.5KHz 80dB XTAL FLTR 45.1MHz 20/25KHz 80dB

Circuit Ref	Motorola Part No.	Description
Y5202	9102651Y02 9102652Y02	XTAL FLTR 45.1MHz 12.5KHz 60dB XTAL FLTR 45.1MHz 20/25KHz 60dB
Y5211	4802653Y01	XTAL OSC 44.645MHz