

A Simple RF Power Calibrator

This compact, self-contained, accurate RF power calibrator is easy to build and fills a long-standing Amateur Radio experimenter need.

By Bob Kopski, K3NHI

In recent years, both *QST* and *QEX* have featured several homebrew RF measurement instruments. These included two RF power meters^{1, 2} and a spectrum analyzer.³ Additionally, some enthusiasts are fortunate enough to have commercial instruments available for home use. All of these RF instruments share one common need—calibration.

RF calibration often becomes a “sticking point” for the hobbyist because this normally requires another piece of commercial gear—one that’s not always readily available. Not anymore! Here is an easily built, low-cost

¹Notes appear on page 54.

battery-operated RF calibration source that is accurate and readily meets the needs above.

The calibrator presented here is based on a standard CMOS clock oscillator. These are low in cost, easy to use and available in a wide range of crystal-controlled frequencies from many mail-order houses. This design uses one for 10 MHz (see Figs 1 and 2).

Because it is CMOS based, the output square wave is a near full-supply voltage swing into a light load: from ground to near the supply voltage of 5 V, nominal. (A TTL output clock with a less-defined swing will *not* work properly in this design.)

If a regulated voltage is supplied to the CMOS oscillator and the load is fixed, the known output signal swing remains stable and has a predictable power level associated with

it. This signal—a square wave shape notwithstanding—is the basis of this calibrator. Incidental to this is the fact that the frequency is also a known stable value; this is of some additional utility as will be seen later.

Design and Operation

Because the clock waveform is square-shaped and swings from ground upward, it has an easily measured average dc value: $\frac{1}{2} V_{\text{pk-pk}}$. This nifty detail and some arithmetic make it easy to produce an accurate calibration source. However, the nominal 5 V_{pk-pk} clock output is much too large for our purposes, so it is divided down to a smaller value. As seen in the schematic, the clock output is routed through R1 and R2 to a nominal 20 dB attenuator (pad) consisting of R4, R5 and R6 and then to the output.

The calibrator output impedance is very close to 50 Ω .

A test point located at the R2 / pad-input interface allows easy measurement and adjustment of the average dc value. The low-pass components, R3 and C3, remove any concerns about the square wave affecting the reading. The voltage at this point is high enough to permit a quality measurement, but it is still too high for our end use. Thus, the pad further attenuates the signal with known accuracy and provides a good output match as well.

Adjustable resistor R2 trims the test-point signal level to a specific 158 mV dc value as measured with a standard DVM. This represents a peak-to-peak square wave of 316 mV at the pad input and 31.6 mV_{pk-pk} on a 50 Ω load following the 20 dB pad. I selected 31.6 mV_{pk-pk} as a "good" calibration level for my (*QEX*) power meter design and for the similar *QST* version too. (They have the same RF sections.) However, it's also perfectly good for other RF instruments. Here's the "how" and "why."

Both the *QST* and *QEX* instruments are based on the Analog Devices AD8307 500 MHz logarithmic amplifier IC. This device is itself *not* directly a power measuring device. Sophisticated power meters employ heat-measuring techniques to determine the applied power level. The 8307 simply provides a log-voltage output representative of the applied input voltage. These two power meters use this characteristic, apply it to an assumed sinusoidal RF voltage on a 50 Ω input impedance, and then represent that signal as a power reading. While the meters do an excel-

lent job at this, the operative word here is "sinusoidal."

Should an applied waveform not be sinusoidal, such as with a harmonic-rich signal, the displayed power will be in error. (This would not be so with heat-measuring power meters.) While working with my *QEX* meter, I stumbled upon the apparent fact that applied square waves having a peak-to-peak value of one-half of a sinusoid peak-to-peak waveform results in the same power reading as the latter.

Being unsure if this was a quirk or (hopefully) an operational behavior based on solid rationale, I inquired of Analog Devices Applications Engineering. I got the happy response that this behavior is solidly based on the design behavior of the AD8307. It all has to do with the way the chip measures voltage and on the crest factor of the applied waveform. In fact, AD referred me to their data sheet on a similar product, the AD640, which describes this same operational behavior in greater detail.

This is a serendipitous discovery, because it makes accurate calibration of the 8307-based power meter very easy to do. One needs only an easy-to-measure square wave and to apply the waveform relationship above. Thus, the 31.6 mV_{pk-pk} square-wave output of this calibrator has a 63.2 mV peak-to-peak sine equivalent, or $63 / 2.83 = 22.3$ mV_{RMS}, as far as the AD8307 is concerned.

The power in 50 Ω associated with the 22.3 mV_{RMS} is $(V_{RMS} \times V_{RMS} / R = 0.00995$ W, or essentially 10 mW. In dBm (which the meter displays), this is $10 \log (0.01)$ or -20 dBm. The *QST* /

QEX power meters can be calibrated simply by connecting this source and adjusting them to read -20 ". What if you have a power meter based on thermal measurements, which most lab instruments are?

It turns out this calibrator is just as useful, but the numbers are different. The ac RMS value ("heat value") of the 31.6 mV square wave is simply $31.6/2 = 15.8$ mV. The power on 50 Ω is $(15.8 \text{ mV} \times 15.8 \text{ mV}) / 50 = 4.992$ mW. This is -23 dBm. Thus, one could connect this calibrator to any standard lab power meter sensor and look for -23 dBm" as the proper instrument response, but there is more.

Like power meters, spectrum analyzers (SA) need a known power level reference to be most useful. Because SAs display the harmonic makeup of an applied non-sinusoid, the waveform from this calibrator produces a crisp comb display. Thus, the simple square wave is represented by its frequency component makeup, and being a symmetrical waveform only odd-order harmonics should be present. Fig 3 shows what the spectral lines of this calibrator look like up to 100 MHz.

Clearly, the dominant lines begin at 10 MHz—the fundamental frequency—and then appear in diminishing amplitude at every odd harmonic: 30, 50, 70 and 90 MHz. Smaller lines appear at the even frequencies

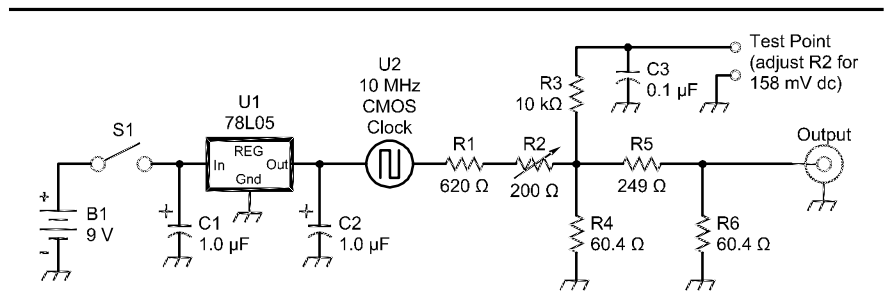

Fig 1—Schematic of the RF power calibrator. Unless otherwise specified, use 1/4 W, 5%-tolerance carbon composition or film resistors.

C1, C2—1.0 μ F, 35 V tantalum

C3—0.1 μ F, ceramic

R1—620 Ω

R2—200 Ω trim pot, Digi Key EVM-36GA00B22 or equivalent

R3—10 k Ω

R4, R6—60.4 Ω , 1/4 W, \pm 1% film

R5—249 Ω , 1/4 W, \pm 1% film

U1—5 V regulator, LM78L05

U2—Oscillator, 10 MHz, CTX 045, Digi Key CTX114-ND or equivalent.

Battery, 9 V, alkaline

Battery snap-on connector, Mouser

12BC016 or equivalent

Housing, LMB, Mouser 537-M00-P or as desired.

1/4-inch threaded standoffs, Mouser 534-8712 or equivalent

DPDT slide switch, Mouser 629-GF-1126-1110 or equivalent

Output connector as desired

Assorted screws, solder, tie wrap, pc board, assorted hardware, etc

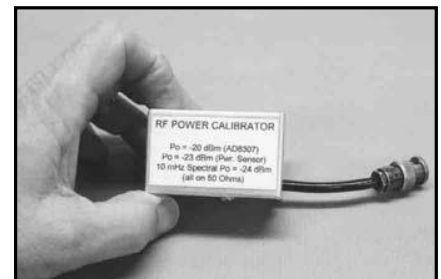

(A)



(B)

Fig 2—Compact, self-contained, accurate RF power calibrator is easy to build and fills a long-standing Amateur Radio experimenter need.

(20 MHz, 40 MHz, etc) because the waveform is not perfectly symmetrical in every respect. However, the power associated with the “evens” is clearly well below that of the “odds,” and the first (or fundamental) power is the “heaviest hitter” of all—just as it should be. Just how much power should this spectral line represent?

The sine peak-to-peak equivalent voltage associated with a given harmonic in an ideal square wave is given by:

$$V_{pk-pk} = \frac{4 \times V_{pk-pk}}{n \times \pi} \quad (\text{Eq 1})$$

where

n = the harmonic of interest

Since the 10-MHz fundamental is the “first harmonic,” its peak-to-peak sine equivalent voltage is $(4 \times 31.6) / 3.1416 = 40.2$ mV. Therefore, the RMS sine-equivalent voltage is $40.2 / 2.83 = 14.2$ mV_{RMS}. The power in 50 Ω associated with this voltage is $(14.2 \text{ mV} \times 14.2 \text{ mV}) / 50 = 4.03$ μW or -24 dBm. This known value can be used to set up the scale of any spectrum analyzer, that is, to establish a “reference level” with which to compare other spectral lines on a display.

As an example, consider the line at 50 MHz in the Fig 3. What is the power associated with this harmonic? Using the same simple math, but with $n = 5$ (the fifth harmonic), we get $(4 \times 31.6) / (5 \times 3.1416) = 8.04$ mV_{pk-pk} sine equivalent. The RMS sine equivalent is 2.84 mV_{RMS}, and the associated power in 50 Ω is 0.162 μW or -37.9 dBm. The spectrum analyzer is actually displaying just about -38.1 dBm—not shabby! (I read this more accurately by expanding the vertical scale of the SA to 5 dB/div.)

As a “final test” I also looked at the ninth harmonic (90 MHz) and found it to be -45 dBm on the SA display. The calculated value is -43 dBm. I believe the discrepancy at this high harmonic value is largely due to imperfection in the waveform. Basically, the waveform rise and fall times are just not fast enough to accurately contain and represent such a high harmonic frequency, I feel. Nevertheless, even this incidental performance is quite good.

Speaking of incidental performance, that previously mentioned utility of the clock being 10 MHz allows the specific harmonics discussed above. Thus, the 10 MHz is a very convenient frequency with which to place markers and/or check-out the sweep linearity of a homebrew (or any other) SA, at least up through some reasonable frequency span.

As an aside, the homebrew spectrum

analyzer pictured is my rendering of the QST SA. It is a “stretched” version of this popular published design and tunes to a bit over 100 MHz. I also added more panel features than the original. While fully useful as is, it is still an evolving work in progress—an ongoing fun project in its own right.

Here are three design and operational notes of interest for the calibrator. First, be sure to have a 50 Ω termination on the calibrator output when adjusting R2 for the specified 158 mV DVM reading as above. This is to correctly represent how the calibrator will be used since RF instruments normally have a 50 Ω input impedance. In fact, you can trim R2 for the 158 mV dc test-point value while the calibrator is connected to such an instrument.

Second, what happens if the CMOS clock does not have a symmetrical output waveform? Based on 11 oscillators I’ve looked at, this is very unlikely. In any case, I’ve experimentally determined that asymmetry by as much as 5% only results in about a 0.5 dB error. Not to worry!

Finally, even though the output signal does have an average dc component, all RF instruments of which I’m aware have either ac-coupled inputs or inputs that are not affected by this low-level dc component—this for those who caught this subtlety!

Assembly Notes

There is not much that is assem-

bly-critical in this calibrator. As the photos show, mine is “ugly constructed.” You can download a diagram of how I placed the components from ARRLWeb.⁴ Follow this approach or another as you wish. In any case, I recommend staying with the basic pc-board “ground plane” idea as shown. This helps assure proper operation of the resistive divider and pad and maintains a quality waveform shape at the output. (Point to point wiring on perforated board would likely degrade these performance aspects.)

The pc board can be copper coated on either one or both sides. Whatever your choice, be sure to countersink away copper clearance for leads that go through the board—on both sides! I chose to drill #60 holes for the components with through-leads and then clear the unwanted copper with a finger-twisted ³/₃₂-inch drill bit. Of course, any leads that get soldered to the ground plane are not countersunk. These include two pins on the clock oscillator as shown in Fig 4. Be sure to correctly orient U1 and the clock—these details are also visible in the Figs 4, 5 and 6.

My power switch—a DPDT slide switch used as a SPST—was easy to mount by simply bending the solder lugs inward along each of the two rows until they were about ¹/₁₆-inch apart, near the middle line. Just solder the six lugs to the copper lands as shown. Make sure the very edge of the pc-

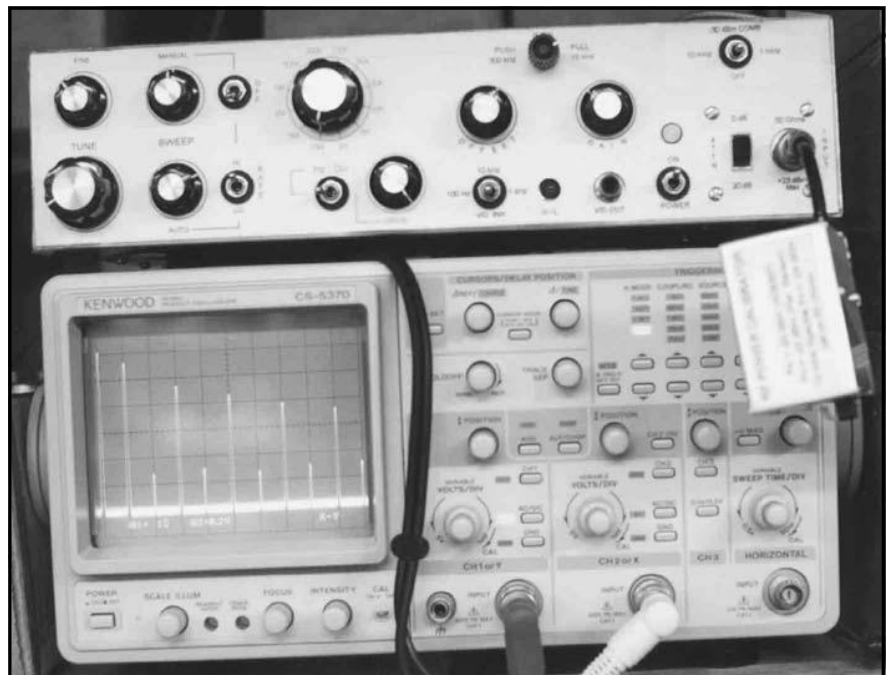

Fig 3—Spectrum-analyzer display of calibrator output. Grid spacing is 10 dB/div vertical, 10 MHz/div horizontal. Tall line at 10 MHz is -24 dBm reference. Note dominance of odd harmonics.

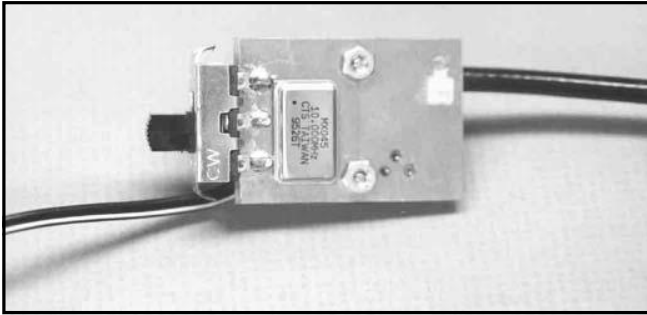

Fig 4—Backside of pc-board chassis. Notice countersunk copper clearance cuts around trimmer pot leads. The switch mounting lugs have been bent back a bit to fit the box.

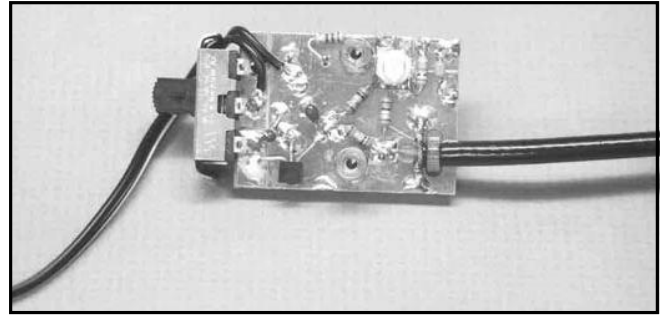

Fig 5—Component-side wiring uses “ugly construction” approach—very easy and effective for assemblies like this. Notice the output cable braid dressed and soldered to the chassis board.

board copper is chamfered back a bit, to not short the switch lugs at the switch body.

The metal enclosure shown (see Fig 6) is a convenience and not a requirement—any containment method is okay. I actually used an “open board” version of the calibrator (with an external power supply via clip leads) for two years before making the much more convenient version shown here. The BNC “pigtail” output has proven convenient for all the applications I have, but a housing-mounted connector would also work just fine.

I used two #4-40 threaded stand-offs to mount the board assembly to the housing. The 9 V battery is wrapped with a single layer of 1/8-inch-thick plastic foam and wedges nicely between the oscillator side of the board assembly and the opposite side of the box. Just make sure the housing cover screws are not long enough to “squeeze” the battery!

Summary

This easily built RF calibrator is useful with a broad range of homebrew and commercial RF instruments. Its accuracy is very good and largely dependent on the DVM used to set it up in the first place—not a very challenging task these days. As an estimate, you should expect accurate power-level representation within about 1/2 dB when applied as described herein. Just remember the calibration values obtained are -20, -23, or -24 dBm depending on the instrument under calibration. In effect, that “sticking point” mentioned in the beginning of this article has just become “well greased”! Enjoy!

Acknowledgement

My gratitude goes out to friend John Hickey, K3HZA, for evaluating the calibrator pictured herein. John

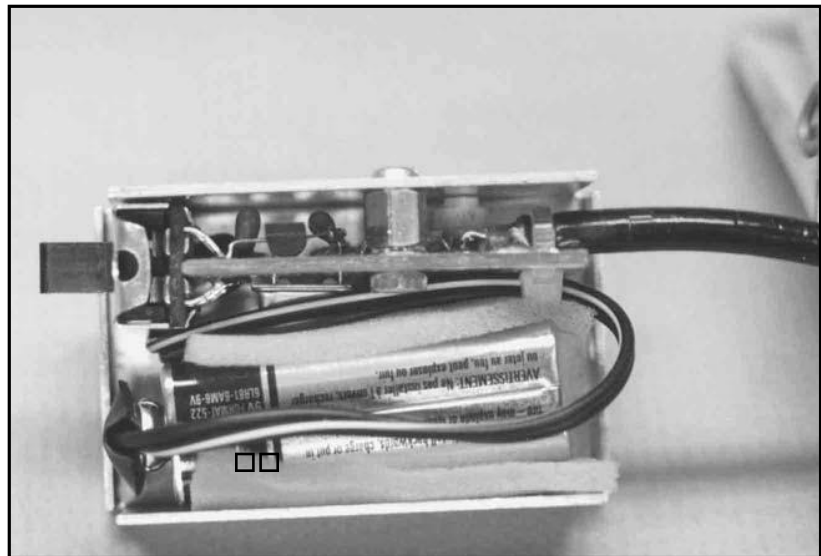

Fig 6—Inside the LMB enclosure. Shielding is not needed; the box is for compact convenience. Notice the DPDT slide-switch attachment to the pc board.

measured the performance using calibration-certified professional laboratory power meters and a spectrum analyzer. Two power meters read -23.3 and -23.4 dBm. The spectrum analyzer yielded -24.2 dBm.

Notes

¹ W. Hayward, W7ZOI, and R. Larkin, W7PUA, “Simple RF Power Measurement,” *QST*, June 2001, pp 38-43.

² R. Kopski, K3NHI, “An Advanced VHF Wattmeter,” *QEX*, May/June 2002, pp 3-8; and “A Simple Enhancement for the Advanced VHF Wattmeter,” *QEX*, Sep/Oct 2003, pp 50-52.

³ W. Hayward, W7ZOI, and T. White, K7TAU, “A Spectrum Analyzer for the Radio Amateur,” *QST*, Aug 1998, pp 35-43.

⁴ You can download this package from the ARRLWeb www.arrl.org/qexfiles/. Look for 0311KOPSKI.ZIP.

Bob is a recently retired Senior Design Engineer from a major defense

contractor. He holds BSEE and BSEP degrees from Lehigh University.

As a life-long electronics, ham and aeromodeling hobbyist, he routinely combines all three pursuits for the fun of it. His Technician ticket dates to about 1959 when he wanted to homebrew 6-meter radio-control equipment for RC models. He still routinely flies on 6 meters and has also operated fixed and mobile there. His broad-based aeromodeling interest dates to the early 1950s, but he has specialized in electric powered RC models for over 25 years. A Contributing Editor to *Model Aviation* magazine for over 20 years, he has a regular monthly column devoted to the electric flying specialty. Additionally, he has published many construction articles covering both model-aircraft design and aeromodeling related electronics. He enjoys it all! □□